



---

## SKID-MOUNTED SUPPORT SYSTEM FOR TEMPORARY GUIDE SIGNS

---



Crash testing performed at:  
TTI Proving Ground  
3100 SH 47, Building 7091  
Bryan, TX 77807

**Test Report No. 0-6782-2**

Cooperative Research Program

TEXAS A&M TRANSPORTATION INSTITUTE  
COLLEGE STATION, TEXAS

TEXAS DEPARTMENT OF TRANSPORTATION

in cooperation with the  
Federal Highway Administration and the  
Texas Department of Transportation  
<http://tti.tamu.edu/documents/0-6782-2.pdf>





1. Report No. FHWA/TX-14/0-6782-2		2. Government Accession No.		3. Recipient's Catalog No.	
4. Title and Subtitle SKID-MOUNTED SUPPORT SYSTEM FOR TEMPORARY GUIDE SIGNS				5. Report Date August 2014	
				6. Performing Organization Code	
7. Author(s) Roger P. Bligh, Dusty R. Arrington, Wanda L. Menges, and Darrell L. Kuhn				8. Performing Organization Report No. Test Report No. 0-6782-2	
9. Performing Organization Name and Address Texas A&M Transportation Institute Proving Ground The Texas A&M University System College Station, Texas 77843-3135				10. Work Unit No. (TRAIS)	
				11. Contract or Grant No. Project 0-6782	
12. Sponsoring Agency Name and Address Texas Department of Transportation Research and Technology Implementation Office 125 E. 11th Street Austin, Texas 78701-2483				13. Type of Report and Period Covered Test Report: September 2013–August 2014	
				14. Sponsoring Agency Code	
15. Supplementary Notes Project performed in cooperation with the Texas Department of Transportation and the Federal Highway Administration. Project Title: Design Standards for Mounting Temporary Large Guide Signs URL: <a href="http://tti.tamu.edu/documents/0-6782-2.pdf">http://tti.tamu.edu/documents/0-6782-2.pdf</a>					
16. Abstract <p>A common issue during phased highway construction projects is the need to temporarily relocate large guide signs on the roadside or install new guide signs for temporary use. The conventional concrete foundations used for these signs are costly and time-consuming to install and remove after construction is completed.</p> <p>A freestanding, skid-mounted support system for temporary large guide signs was developed and successfully crash-tested in accordance with the <i>Manual for Assessing Safety Hardware (MASH)</i> guidelines. The design considered wind loads, ballast requirements, and impact performance. The skid-mounted design eliminates the need for below-ground footers, and permits rapid movement and relocation of the sign.</p> <p>The results of the research have been used to establish guidelines for both the direct embedded temporary wood support system (developed in the first year of the project) and the skid-mounted support system. The guidelines provide the designer with a means of selecting the appropriate number, size, and grade of support posts for a given sign panel size.</p>					
17. Key Words Guide Signs, Sign Supports, Temporary Supports, Skid-Mounted Sign Supports, Direct Embedded Sign Supports, Wind Load Analysis, Crash Testing, Roadside Safety			18. Distribution Statement No restrictions. This document is available to the public through NTIS: National Technical Information Service Alexandria, Virginia 22312 <a href="http://www.ntis.gov">http://www.ntis.gov</a>		
19. Security Classif. (of this report) Unclassified		20. Security Classif. (of this page) Unclassified		21. No. of Pages 144	22. Price



# SKID-MOUNTED SUPPORT SYSTEM FOR TEMPORARY GUIDE SIGNS

by

Roger P. Bligh, Ph.D., P.E.  
Research Engineer  
Texas A&M Transportation Institute

Dusty R. Arrington  
Associate Transportation Researcher  
Texas A&M Transportation Institute

Wanda L. Menges  
Research Specialist  
Texas A&M Transportation Institute

and

Darrell L. Kuhn, P.E.  
Research Specialist  
Texas Transportation Institute

Report 0-6782-2  
Project 0-6782

Project Title: Design Standards for Mounting Temporary Large Guide Signs

Performed in cooperation with the  
Texas Department of Transportation  
and the  
Federal Highway Administration

August 2014

TEXAS A&M TRANSPORTATION INSTITUTE  
College Station, Texas 77843-3135



## DISCLAIMER

This research was performed in cooperation with the Texas Department of Transportation (TxDOT) and the Federal Highway Administration (FHWA). The contents of this report reflect the views of the authors, who are responsible for the facts and the accuracy of the data presented herein. The contents do not necessarily reflect the official view or policies of the FHWA or TxDOT. This report does not constitute a standard, specification, or regulation, and its contents are not intended for construction, bidding, or permit purposes. In addition, the above listed agencies assume no liability for its contents or use thereof. The United States Government and the State of Texas do not endorse products or manufacturers. Trade or manufacturers' names appear herein solely because they are considered essential to the object of this report. The engineer in charge of the project was Roger P. Bligh, P.E. (Texas, #78550).

## TTI PROVING GROUND DISCLAIMER

The results of the crash testing reported herein apply only to the article being tested.

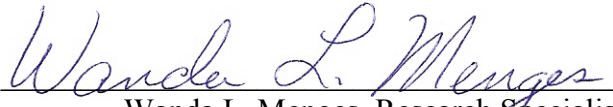

  
Wanda L. Menges, Research Specialist  
Deputy Quality Manager

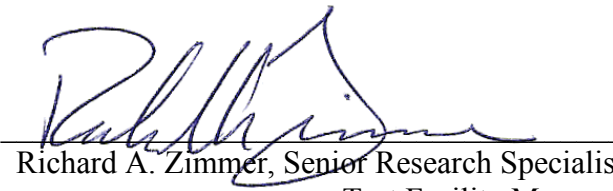
  
Richard A. Zimmer, Senior Research Specialist  
Test Facility Manager  
Quality Manager  
Technical Manager

## **ACKNOWLEDGMENTS**

This research project was conducted under a cooperative research program between the Texas A&M Transportation Institute (TTI), the Texas Department of Transportation, and the U.S. Department of Transportation, Federal Highway Administration. Darrin Jensen, with the TxDOT Research and Technology Implementation Office, served as the project manager. Members of the Project Management Committee included Jeremy Dearing (Lubbock District), Guillermo Dougherty (Laredo District), Carlos Ibarra (Atlanta District), Jesus Leal (Pharr District), Doug Skowronek (Traffic Operations Division), and Gary Tarter (Traffic Operations Division). These individuals were actively involved in all aspects of this research, and the authors acknowledge and appreciate their invaluable guidance and assistance.

# TABLE OF CONTENTS

	Page
<b>List of Figures</b> .....	v
<b>List of Tables</b> .....	viii
<b>Chapter 1. Introduction</b> .....	<b>1</b>
1.1 Background.....	1
1.2 Objectives/Scope of Research .....	1
<b>Chapter 2. Design of Skid-Mounted Support System for Temporary Guide Signs</b> .....	<b>3</b>
2.1 Support Selection.....	3
2.2 Wind Load Analysis .....	3
2.3 Overturning Analysis.....	6
2.4 Post Activation.....	9
2.5 Sign Substrate Connection.....	9
2.6 Crashworthiness.....	10
2.7 Recommended Design .....	12
<b>Chapter 3. MASH Crash Test Requirements and Procedures</b> .....	<b>13</b>
3.1 Test Facility .....	13
3.2 Crash Test Matrix .....	13
3.3 Evaluation Criteria.....	14
3.4 Vehicle Tow and Guidance Procedures.....	14
3.5 Data Acquisition Systems.....	14
3.5.1 Vehicle Instrumentation and Data Processing .....	14
3.5.2 Anthropomorphic Dummy Instrumentation.....	15
3.5.3 Photographic Instrumentation and Data Processing .....	15
<b>Chapter 4. Crash Testing of Skid-Mounted Support System for Temporary Guide Signs</b> .....	<b>17</b>
4.1 Test Article Design and Construction.....	17
4.2 <i>MASH</i> Test 3-70 on the Skid-Mounted Support System for Temporary Guide Signs (Test No. 467824-1).....	19
4.2.1 Test Designation and Actual Impact Conditions .....	19
4.2.2 Test Vehicle .....	19
4.2.3 Weather Conditions .....	20
4.2.4 Test Description .....	20
4.2.5 Damage to Test Installation .....	20
4.2.6 Vehicle Damage.....	20
4.2.7 Occupant Risk Factors .....	21
4.2.8 Assessment of Test Results.....	22
4.3 <i>MASH</i> Test 3-71 on the Skid-Mounted Support System for Temporary Guide Signs (Test No. 467824-2).....	24
4.3.1 Test Designation and Actual Impact Conditions .....	24
4.3.2 Test Vehicle .....	24
4.3.3 Weather Conditions .....	24
4.3.4 Test Description .....	25
4.3.5 Damage to Test Installation .....	25
4.3.6 Vehicle Damage.....	25
4.3.7 Occupant Risk Factors .....	27

## TABLE OF CONTENTS (CONTINUED)

	Page
4.3.8 Assessment of Test Results.....	29
4.4 Design Modifications.....	30
4.5 <i>MASH</i> Test 3-71 on the Modified Skid-Mounted Support System for Temporary Guide Signs (Test No. 467824-4).....	32
4.6.1 Test Designation and Actual Impact Conditions .....	32
4.6.2 Test Vehicle .....	32
4.6.3 Weather Conditions .....	32
4.6.4 Test Description .....	32
4.6.5 Damage to Test Installation .....	33
4.6.6 Vehicle Damage.....	34
4.6.7 Occupant Risk Factors .....	34
4.6.8 Assessment of Test Results.....	34
4.7 <i>MASH</i> Test 3-72 on the Modified Skid-Mounted Support System for Temporary Guide Signs (Test No. 467824-3).....	37
4.7.1 Test Designation and Actual Impact Conditions .....	37
4.7.2 Test Vehicle .....	37
4.7.3 Weather Conditions .....	37
4.7.4 Test Description .....	37
4.7.5 Damage to Test Installation .....	38
4.7.6 Vehicle Damage.....	38
4.7.7 Occupant Risk Factors .....	38
4.7.8 Assessment of Test Results.....	41
4.8 Conclusions.....	42
<b>Chapter 5. Guidelines for Temporary Support Systems for Guide Signs.....</b>	<b>43</b>
5.1 Direct Embedded Wood Support System .....	43
5.2 Direct Embedded Steel Support System.....	47
5.3 Freestanding, Skid-Mounted Sign Support System.....	48
5.4 Summary.....	50
<b>Chapter 6. Summary and Conclusions .....</b>	<b>51</b>
6.1 Skid-Mounted Support System for Temporary Guide Signs.....	51
6.2 Guidelines for Temporary Sign Support Systems for Large Guide Signs.....	52
<b>Chapter 7. Implementation Statement.....</b>	<b>57</b>
7.1 Skid-Mounted Support System for Temporary Guide Signs.....	57
7.2 Guidelines for Temporary Sign Support Systems for Large Guide Signs.....	57
<b>References.....</b>	<b>59</b>
<b>Appendix A. Details of the Test Article for Test Nos. 467824-1 and 467824-2 .....</b>	<b>61</b>
<b>Appendix B. Certification Documentation for Test Nos. 467824-1 and 467824-2 .....</b>	<b>69</b>
<b>Appendix C. Crash Test Data and Information for Test No. 467824-1 .....</b>	<b>71</b>
<b>Appendix D. Crash Test Data and Information for Test No. 467824-2 .....</b>	<b>83</b>
<b>Appendix E. Details of the Test Article for Test Nos. 467824-4 and 467824-3.....</b>	<b>95</b>
<b>Appendix F. Certification Documentation for Test Nos. 467824-4 and 467824-3 .....</b>	<b>103</b>
<b>Appendix G. Crash Test Data and Information for Test No. 467824-4.....</b>	<b>105</b>
<b>Appendix H. Crash Test Data and Information for Test No. 467824-3.....</b>	<b>117</b>



## LIST OF FIGURES

	Page
Figure 2.1. Texas Wind Load Isotachs ( <i>I</i> ).....	4
Figure 4.1. Overall Details of the Skid-Mounted Support System Temporary Guide Sign....	17
Figure 4.2. Skid-Mounted Support System for Temporary Guide Signs before Test Nos. 467824-1 and 467824-2.....	19
Figure 4.3. Vehicle before Test No. 467824-1.....	20
Figure 4.4. Skid-Mounted Support System for Temporary Guide Signs after Test No. 467824-1.....	21
Figure 4.5. Vehicle after Test No. 467824-1.....	21
Figure 4.6. Summary of Results for <i>MASH</i> Test 3-70 on the Skid-Mounted Sign Support System for Temporary Guide Signs.....	23
Figure 4.7. Vehicle before Test No. 467824-2.....	25
Figure 4.8. Skid-Mounted Support System for Temporary Guide Signs after Test No. 467824-2.....	26
Figure 4.9. Vehicle after Test No. 467824-2.....	27
Figure 4.10. Summary of Results for <i>MASH</i> Test 3-71 on the Skid-Mounted Support System for Temporary Guide Signs with Five Support Posts.....	28
Figure 4.11. Modified Skid-Mounted Support System for Temporary Guide Signs before Test Nos. 467824-3 and 467824-4.....	31
Figure 4.12. Vehicle before Test No. 467824-4.....	32
Figure 4.13. Modified Skid-Mounted Support System after Test No. 467824-4.....	33
Figure 4.14. Vehicle after Test No. 467824-4.....	34
Figure 4.15. Summary of Results for <i>MASH</i> Test 3-71 on the Modified Skid-Mounted Support System for Temporary Guide Signs.....	35
Figure 4.16. Vehicle before Test No. 467824-3.....	37
Figure 4.17. Modified Skid-Mounted Support System for Temporary Guide Signs after Test No. 467824-3.....	39
Figure 4.18. Vehicle after Test No. 467824-3.....	39
Figure 4.19. Summary of Results for <i>MASH</i> Test 3-72 on the Modified Skid-Mounted Support System for Temporary Guide Signs.....	40
Figure 5.1. Design Chart for Direct Embedded Wood Support System with Rough Sawn Posts (60 mph Design Wind Speed).....	45
Figure 5.2. Design Chart for Direct Embedded Wood Support System with S4S Posts (60 mph Design Wind Speed).....	45
Figure 5.3. Design Chart for Direct Embedded Wood Support System Rough Sawn Posts (70 mph Design Wind Speed).....	46
Figure 5.4. Design Chart for Direct Embedded Wood Support System with S4S Posts (70 mph Design Wind Speed).....	46
Figure 5.5. Design Chart for Post Selection for Skid-Mounted Sign Support System.....	49
Figure 5.6. Design Chart for Ballast Required for Skid-Mounted Sign Support System.....	50
Figure C1. Sequential Photographs for Test No. 467824-1 (Perpendicular and Oblique Views).....	74
Figure C2. Vehicle Angular Displacements for Test No. 467824-1.....	76

## LIST OF FIGURES (CONTINUED)

		<b>Page</b>
Figure C3.	Vehicle Longitudinal Accelerometer Trace for Test No. 467824-1 (Accelerometer Located at Center of Gravity). .....	77
Figure C4.	Vehicle Lateral Accelerometer Trace for Test No. 467824-1 (Accelerometer Located at Center of Gravity). .....	78
Figure C5.	Vehicle Vertical Accelerometer Trace for Test No. 467824-1 (Accelerometer Located at Center of Gravity). .....	79
Figure C6.	Vehicle Longitudinal Accelerometer Trace for Test No. 467824-1 (Accelerometer Located Rear of Center of Gravity). .....	80
Figure C7.	Vehicle Lateral Accelerometer Trace for Test No. 467824-1 (Accelerometer Located Rear of Center of Gravity). .....	81
Figure C8.	Vehicle Vertical Accelerometer Trace for Test No. 467824-1 (Accelerometer Located Rear of Center of Gravity). .....	82
Figure D1.	Sequential Photographs for Test No. 467824-2 (Perpendicular and Oblique Views). .....	86
Figure D2.	Vehicle Angular Displacements for Test No. 467824-2. ....	88
Figure D3.	Vehicle Longitudinal Accelerometer Trace for Test No. 467824-2 (Accelerometer Located at Center of Gravity). .....	89
Figure D4.	Vehicle Lateral Accelerometer Trace for Test No. 467824-2 (Accelerometer Located at Center of Gravity). .....	90
Figure D5.	Vehicle Vertical Accelerometer Trace for Test No. 467824-2 (Accelerometer Located at Center of Gravity). .....	91
Figure D6.	Vehicle Longitudinal Accelerometer Trace for Test No. 467824-2 (Accelerometer Located Rear of Center of Gravity). .....	92
Figure D7.	Vehicle Lateral Accelerometer Trace for Test No. 467824-2 (Accelerometer Located Rear of Center of Gravity). .....	93
Figure D8.	Vehicle Vertical Accelerometer Trace for Test No. 467824-2 (Accelerometer Located Rear of Center of Gravity). .....	94
Figure G1.	Sequential Photographs for Test No. 467824-4 (Perpendicular and Oblique Views). .....	108
Figure G2.	Vehicle Angular Displacements for Test No. 467824-4. ....	110
Figure G3.	Vehicle Longitudinal Accelerometer Trace for Test No. 467824-4 (Accelerometer Located at Center of Gravity). .....	111
Figure G4.	Vehicle Lateral Accelerometer Trace for Test No. 467824-4 (Accelerometer Located at Center of Gravity). .....	112
Figure G5.	Vehicle Vertical Accelerometer Trace for Test No. 467824-4 (Accelerometer Located at Center of Gravity). .....	113
Figure G6.	Vehicle Longitudinal Accelerometer Trace for Test No. 467824-4 (Accelerometer Located Rear of Center of Gravity). .....	114
Figure G7.	Vehicle Lateral Accelerometer Trace for Test No. 467824-4 (Accelerometer Located Rear of Center of Gravity). .....	115
Figure G8.	Vehicle Vertical Accelerometer Trace for Test No. 467824-4 (Accelerometer Located Rear of Center of Gravity). .....	116

## LIST OF FIGURES (CONTINUED)

	<b>Page</b>
Figure H1. Sequential Photographs for Test No. 467824-3 (Perpendicular and Oblique Views).....	121
Figure H2. Vehicle Angular Displacements for Test No. 467824-3.....	123
Figure H3. Vehicle Longitudinal Accelerometer Trace for Test No. 467824-3 (Accelerometer Located at Center of Gravity). ....	124
Figure H4. Vehicle Lateral Accelerometer Trace for Test No. 467824-3 (Accelerometer Located at Center of Gravity). ....	125
Figure H5. Vehicle Vertical Accelerometer Trace for Test No. 467824-3 (Accelerometer Located at Center of Gravity). ....	126
Figure H6. Vehicle Longitudinal Accelerometer Trace for Test No. 467824-3 (Accelerometer Located Rear of Center of Gravity). ....	127
Figure H7. Vehicle Lateral Accelerometer Trace for Test No. 467824-3 (Accelerometer Located Rear of Center of Gravity). ....	128
Figure H8. ehicle Vertical Accelerometer Trace for Test No. 467824-3 (Accelerometer Located Rear of Center of Gravity). ....	129

## LIST OF TABLES

		<b>Page</b>
Table 2.1.	Wood Material Strength Properties. ....	5
Table 2.2.	Sign Support Requirement Analysis for 4 × 6 Posts. ....	6
Table 2.3.	Sign Support Requirement Analysis for 4 × 4 Posts. ....	6
Table 2.4.	Ballast Requirement for 8-Ft × 16-Ft Sign Panel Mounted at 7 Ft. ....	7
Table 2.5.	Peak Wind Speed Computed as a Function of Mean Recurrence Interval. ....	8
Table 2.6.	Analysis Results for Post Weakening below Sign. ....	9
Table 2.7.	Combined Post Impact Capacity (2-Year Recurrence Interval). ....	11
Table 5.1.	Recommended Embedment Depths for Direct Embedded Wood Support Posts. ....	47
Table 5.2.	Recommended Embedment Depths for Direct Embedded Steel Foundation Posts. ....	48
Table 6.1.	Performance Evaluation Summary for <i>MASH</i> Test 3-70 on the Skid-Mounted Support System for Temporary Guide Signs. ....	53
Table 6.2.	Performance Evaluation Summary for <i>MASH</i> Test 3-71 on the Skid-Mounted Support System for Temporary Guide Signs. ....	54
Table 6.3.	Performance Evaluation Summary for <i>MASH</i> Test 3-71 on the Modified Skid-Mounted Support System for Temporary Guide Signs. ....	55
Table 6.4.	Performance Evaluation Summary for <i>MASH</i> Test 3-72 on the Modified Skid-Mounted Support System for Temporary Guide Signs. ....	56
Table C1.	Vehicle Properties for Test No. 467824-1. ....	71
Table C2.	Exterior Crush Measurements for Test No. 467824-1. ....	72
Table C3.	Occupant Compartment Measurements for Test No. 467824-1. ....	73
Table D1.	Vehicle Properties for Test No. 467824-2. ....	83
Table D2.	Exterior Crush Measurements for Test No. 467824-2. ....	84
Table D3.	Occupant Compartment Measurements for Test No. 467824-2. ....	85
Table G1.	Vehicle Properties for Test No. 467824-4. ....	105
Table G2.	Exterior Crush Measurements for Test No. 467824-4. ....	106
Table G3.	Occupant Compartment Measurements for Test No. 467824-4. ....	107
Table H1.	Vehicle Properties for Test No. 467824-3. ....	117
Table H2.	Vehicle Parametric Measurements for Vehicle CG. ....	118
Table H3.	Exterior Crush Measurements for Test No. 467824-3. ....	119
Table H4.	Occupant Compartment Measurements for Test No. 467824-3. ....	120

# CHAPTER 1. INTRODUCTION

## 1.1 BACKGROUND

A common issue during phased highway construction projects is the need to temporarily relocate large guide signs on the roadside or install new guide signs for temporary use. Many of these signs are larger than 100 ft<sup>2</sup> and cannot be accommodated on small sign supports. The conventional concrete foundations used for large guide signs are costly and time-consuming to install. They are equally costly to remove after construction is completed and, consequently, they are often left in place. This creates problems for mowing and other maintenance operations.

There is a need for something more temporary than steel reinforced drilled concrete shafts for the temporary placement or relocation of large guide signs, and more cost-effective to install and remove. Any such system must be crashworthy and capable of accommodating wind load requirements.

## 1.2 OBJECTIVES/SCOPE OF RESEARCH

The objective of this project was to develop a series of design standards for mounting large temporary guide signs. Various types of guide signs need to be considered, including destination signs, advance exit signs, logo signs, etc. Under Task 1, the Project Monitoring Committee (PMC) members indicated that a common work zone sign is the “Give Us a Brake” sign measuring 16-ft wide × 8-ft tall with an area of 128 ft<sup>2</sup> and is relocated often. If this sign could be practically accommodated, it would serve as a good basis for designs developed under the project.

In the first year of this two-year project, two different sign support systems were developed and successfully crash-tested for use in temporary applications. The first used direct embedded wood supports with weakening holes at the ground line and below the sign panel. The second used direct embedded steel foundation posts in conjunction with standard slip base and fuse plate mechanisms.

This report documents research performed in the second year of the project. A freestanding, skid-mounted support system for large signs was investigated to address situations where embedding the sign supports is not feasible or desired due to cost, site constraints, or the nature of the project.

The analysis and evaluation of this temporary support system included

- Consideration of design wind loads.
- Ballast requirements required to prevent overturning during a design wind event.
- Crashworthiness during vehicle impact.

Wind load and ballast requirements were assessed in terms of the American Association of State Highway and Transportation Officials (AASHTO) *Standard Specifications for Structural Supports for Highway Signs, Luminaires, and Traffic Signals (1)*. Impact performance of the sign support systems was evaluated based on the AASHTO *Manual for*

*Assessing Safety Hardware (MASH) requirements (2). MASH requires up to three full-scale crash tests to evaluate the crashworthiness of a breakaway sign support structure.*

In addition, the results of the research were used to establish design guidelines for the use of the direct embedded temporary wood and steel support systems (developed in the first year of the project) and the skid-mounted support system described herein. The guidelines provide the designer with a means of selecting the appropriate number, size, and grade of support posts for a given sign panel size. Recommendations are also provided for embedment depth of the direct embedded support systems and ballast requirements for the skid-mounted system.

## CHAPTER 2. DESIGN OF SKID-MOUNTED SUPPORT SYSTEM FOR TEMPORARY GUIDE SIGNS

### 2.1 SUPPORT SELECTION

The evaluation of a wood sign support system includes consideration of factors such as support post size, length, and grade. Availability and cost are also important design considerations. The design approach followed for the skid-mounted sign support system was to use multiple, small wood supports that can independently fracture during impact, rather than fewer larger supports. The support posts must be practically and economically supported by and attached to skids running perpendicular to the sign panel. Larger support posts (e.g., 6 inches  $\times$  8 inches) would require the use of large skid members to develop the moment capacity of the support to withstand wind loads and to promote fracture during an impact. These large skid members could hinder a car's ability to traverse them in a safe and stable manner during an impact. It was more desirable and practical to limit the size of the skid members to nothing larger than 2-inch  $\times$  6-inch wood sections. For these reasons, the researchers considered 4-inch  $\times$  4-inch and 4-inch  $\times$  6-inch wood members as the support sizes for the skid-mounted sign support system.

Because of a desire to fabricate the skid-mounted sign support system from readily available materials, Grade 2 Southern Yellow Pine (SYP) was selected for the design. This grade material is readily available in the selected sizes from any local lumber yard or home improvement store, making it easily accessible to contractors and maintenance personnel. For a given size and grade of support, the required number and spacing of the supports for a given size sign is determined based on wind load and crashworthiness requirements as described herein.

### 2.2 WIND LOAD ANALYSIS\*

In addition to being crashworthy, sign supports are designed to meet wind load requirements described in AASHTO *Standard Specifications for Structural Supports for Highway Signs, Luminaires and Traffic Signals (1)*. There are currently two acceptable methods in the specification for calculating wind pressures on signs. Section 3 of the specification describes the current method, which is an attempt to unify wind load design with that of other structures. However, the legacy method is still considered acceptable for determining wind load values for signs, and is included as Appendix C of the design specification. One method is not considered more conservative than the other is. Both methods result in similar overall wind pressures, although some differences may exist depending on geographic location.

The design wind pressure is based on the basic wind speed and the anticipated design life of the structure. The basic wind speed is associated with the annual probability of 0.02 (or a 50-year mean recurrence interval), and is prescribed by isotachs contained in the AASHTO *Standard Specifications for Structural Supports for Highway Signs, Luminaires and Traffic Signals*. Figure 2.1 shows that the basic wind speed varies with geographical location across Texas, and ranges from 90 mph to 130 mph near the coast. The basic wind speed is modified by

---

\* The interpretations expressed in this section of the report are outside the scope of TTI's A2LA Accreditation.

an importance factor based on the recommended minimum design life of a structure. The recommended minimum design life for permanent roadside sign structures is 10 years.

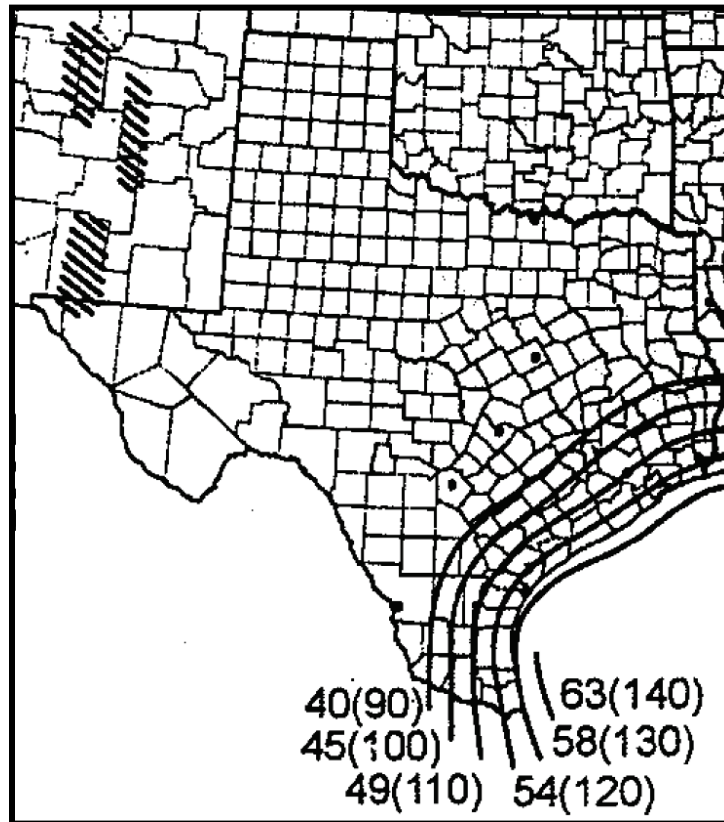

Figure 2.1. Texas Wind Load Isotachs (*I*).

The design wind pressure is computed from the following equation:

$$P_z = 0.00256 K_z G (V * C_v)^2 I_r C_d \text{ (psf)}$$

where

- $P_z$  = Design Wind Pressure (psf).
- $I_r$  = Wind Importance Factor.
- $C_v$  = Velocity Conversion Factor.
- $K_z$  = Height and Exposure Factor.
- $G$  = Gust Effect Factor.
- $C_d$  = Wind Drag Coefficients.
- $V$  = Basic Wind Speed (mph) from Wind Chart.

According to Figure 2.1, a wind speed of 90 mph covers approximately 80 percent of Texas. A wind speed of 110 mph covers approximately 90 percent of the state. A wind speed of 120 mph covers almost all of the state with the exception of some narrow coastal areas. A wind speed of 130 mph covers all of the state. Since all high wind zones in Texas are located along the gulf coast, a hurricane region, the current wind load calculation method allows for the reduction of wind speed. The resulting wind pressure must equal or exceed the calculated wind pressures for a non-hurricane zone wind speed of 100mph.



The current method defines permanent sign supports as having a design life of 10 years or less. A 90-mph design wind speed with a 10-year recurrence interval equates to a wind pressure of 11.5 psf. This represents a total wind load of 1469 lb when applied to the 128 ft<sup>2</sup> sign. A 100-mph design wind speed equates to a wind pressure of 14.2 psf and a total wind load of 1813 lb. These wind loads can be applied to the resultant height of a sign panel to determine the required number of support posts of a certain size and grade as well as the required amount of ballast needed to prevent a skid-mounted sign support system from overturning when subjected to a design wind event.

There are many factors involved in determining the minimum number and spacing of support posts required. The primary factors include sign size, sign mounting height, post size, and post grade. Table 2.1 shows that post size and grade directly affect the material strength of the post (values taken from current wind load calculation method). For a given post size, Grade 2 material is not as strong as Grade 1 material. This means that a larger number of Grade 2 posts are needed to support a given size sign than Grade 1 posts. However, the cost of an additional Grade 2 post may be offset by its common availability and lower cost of the Grade 2 material.

**Table 2.1. Wood Material Strength Properties.**

Stress, psi	4 × 4		4 × 6	
	Grade 2	Grade 1	Grade 2	Grade 1
F <sub>b</sub> (flexure)	1500	1850	1250	1650
F <sub>t</sub> (tension)	825	1050	725	900
F <sub>v</sub> (shear)	90	100	90	90
F <sub>c</sub> (compression)	1650	1850	1600	1750

The results of a wind load analysis performed for a 128 ft<sup>2</sup> sign are shown in Table 2.2 and Table 2.3 for 4-inch × 6-inch support posts and 4-inch × 4-inch support posts, respectively. Note that results are provided for both the current and legacy (Appendix C) wind load methods for cross-reference purposes because TxDOT standard design detail sheets are based on the legacy method. In Table 2.2, the analysis shows that eight Grade 2, 4-inch × 6-inch support posts are needed for a 90-mph design wind speed. This provides a post spacing of 2 ft for an 8-ft tall × 16-ft wide sign, assuming 12 inches of sign overhang beyond the outermost support posts. The number of posts impacted is determined using post spacing and the width of the *MASH* design test vehicles. In the present example, Table 2.2 indicates that four of the eight support posts would be impacted by the pickup truck design vehicle, which is typically a Dodge Ram, 4-door, ½-ton truck. The overall width of the Dodge pickup (excluding mirrors) is approximately 77 inches.

Alternatively, if 4-inch × 4-inch, Grade 2 supports were used, Table 2.3 indicates that 14 posts would be required to accommodate a 90-mph design wind speed. At a spacing less than 14 inches, the pickup truck design test vehicle would impact six posts.

**Table 2.2. Sign Support Requirement Analysis for 4 × 6 Posts.**

			Number of Posts					
			6x4					
Wind Cals			Sx	Grade	Fb	Sx	Grade	Fb
			24	Gr 1	1650	24	Gr 2	1250
Recurrence Interval	mph	mph	# of Posts	Spacing	# Impacted	# of Posts	Spacing	# Impacted
	Current	Apend C						
10	97.0	<b>70.0</b>	7	27.43	<b>3</b>	9	21.33	<b>4</b>
	<b>90.0</b>	65.0	6	32.00	<b>3</b>	8	24.00	<b>4</b>
	83.1	<b>60.0</b>	5	38.40	<b>3</b>	7	27.43	<b>3</b>
2	66.5	<b>48.0</b>	4	48.00	<b>2</b>	5	38.40	<b>3</b>
1.5	62.4	45.0	3	64.00	2	4	48.00	2
1	59.6	43.0	3	64.00	2	4	48.00	2
0.5	51.3	37.0	2	96.00	1	3	64.00	2

**Table 2.3. Sign Support Requirement Analysis for 4 × 4 Posts.**

			Number of Posts					
			4x4					
Wind Cals			Sx	Grade	Fb	Sx	Grade	Fb
			10.67	Gr 1	1850	10.67	Gr 2	1500
Recurrence Interval	mph	mph	# of Posts	Spacing	# Impacted	# of Posts	Spacing	# Impacted
	Current	Apend C						
10	97.0	<b>70.0</b>	13	14.77	<b>6</b>	17	11.29	<b>7</b>
	<b>90.0</b>	65.0	12	16.00	<b>5</b>	14	13.71	<b>6</b>
	83.1	<b>60.0</b>	10	19.20	<b>5</b>	12	16.00	<b>5</b>
2	66.5	<b>48.0</b>	7	27.43	<b>3</b>	8	24.00	<b>4</b>
1.5	62.4	45.0	6	32.00	3	7	27.43	3
1	59.6	43.0	5	38.40	3	7	27.43	3
0.5	51.3	37.0	4	48	2	5	38.40	3

### 2.3 OVERTURNING ANALYSIS

A skid-mounted design is more portable and can be more easily moved or relocated on the job site. However, because it does not have a ground-mounted foundation, proper ballast should be provided to prevent overturn of skid-mounted system when subjected to the selected design wind event.

The researchers performed an overturning analysis to determine the amount of ballast required for the skid-mounted temporary sign support system for different wind speeds. Using the calculated wind pressure applied to the sign panel, the maximum overturning moment was computed. This moment was then used to determine the amount of ballast (in the form of 40-lb

sand bags) required on the skids to prevent overturn of the sign support system during a design wind event.

Table 2.4 shows the number of sand bags required to prevent overturn of an 8-ft tall × 16-ft wide (128 ft<sup>2</sup>) sign mounted at a height of 7 ft above ground subjected to different design wind speeds. One hundred and two sand bags are required for a 90-mph design wind speed. This number of sand bags is impractical and offsets the benefits associated with a portable, skid-mounted sign support system.

**Table 2.4. Ballast Requirement for 8-Ft × 16-Ft Sign Panel Mounted at 7 Ft.**

Wind Speed		Ballast		
mph	mph	lbs	# of 40 lb	# of bags
Current	Apemd C	W Ballast	Bags	per side
97.0	<b>70.0</b>	4736.0	120	<b>60</b>
<b>90.0</b>	65.0	4077.6	102	<b>51</b>
83.1	<b>60.0</b>	3479.5	88	<b>44</b>
66.5	<b>48.0</b>	2226.9	56	<b>28</b>
55.4	40.0	1546.4	40	20
48.5	35.0	1184.0	30	15
41.6	30.0	869.9	22	11

One means of reducing the amount of ballast to more practical levels is to reduce the design wind speed. Note that as the design wind speed is decreased, the probability or percentage of blow-downs or overturns will increase. However, given the frequent activity at most work zone locations, a certain percentage of blow-downs during severe storms or other high wind speed events can probably be tolerated and quickly corrected.

Reducing the design wind speed also permits the size and/or number of support posts to be reduced. There is no point in designing the structural capacity of the sign supports for a wind speed significantly greater than the wind speed that will cause overturn. Further, there is little point establishing a design wind speed to address structural adequacy and overturn if the required amount of ballast will not be used.

A rational approach is to select a design wind speed based on a reasonable duration for the work zone construction projects for which use of the skid-mounted temporary guide signs is anticipated. Unfortunately, there are no isotach maps or importance factors provided in the AASHTO Specifications for mean recurrence intervals of less than 10 years. Therefore, it is necessary to extrapolate the design wind speeds associated with shorter mean recurrence intervals.

In a paper entitled “Design Wind Load Determination for Work Zone Traffic Control Devices” (3), Bligh used a Type-I Distribution and wind speed conversion factors from ANSI/ASCE Standard 7-95 for mean recurrence intervals ranging from 5 years to 500 years to extrapolate wind speed conversion factors for shorter mean recurrence intervals. Design wind speeds for a given mean recurrence interval were then determined by multiplying the design wind speed for a 50-year mean recurrence interval by the corresponding conversion factor.

Table 2.5 presents the results of the analysis. As an example, the 1-year peak wind speed would be 43 mph given a 50-year wind speed of 70 mph. Note that for the legacy method, a 50-year wind speed of 70 mph covers most of Texas except for the extreme coastal locations.

**Table 2.5. Peak Wind Speed Computed as a Function of Mean Recurrence Interval.**

Mean Recurrence Interval		Conversion Factor	Peak Wind Speed, (mph)
Months	Years		
600	50	1.00*	70
300	25	0.93*	65
120	10	0.84*	59
60	5	0.78*	55
24	2	0.68**	48
18	1.5	0.65**	45
12	1	0.61**	43
6	0.5	0.53**	37

\* Values published in ANSI/ASCE 7-95

\*\* Values computed from probability distribution (3)

A mean recurrence interval of 2 years was selected in consultation with the PMC based on expected duration of construction projects for which the application of a skid-mounted guide sign might be expected. As noted in Table 2.5, the design wind speed corresponding to a 2-year recurrence interval is 48 mph. With reference to Table 2.4, it can be seen that for a design wind speed of 48 mph, the amount of ballast required for a 128 ft<sup>2</sup> sign is reduced to 56 40-lb sand bags. The 128 ft<sup>2</sup> sign that was analyzed was selected as the upper end sign area for temporary sign support systems. The amount of ballast required is further reduced for smaller sign panels.

As mentioned previously, a reduction in design wind speed also reduces the structural demand on the support posts. As Table 2.2 shows, the number of 4-inch × 6-inch Grade 2 support posts required for a design wind speed of 48 mph is decreased from eight to five, and the number of posts that the pickup truck design vehicle can simultaneously impact is reduced from four to three.

The selection of a design wind speed of 48 mph reduces the required ballast to a level that would be more practical for securing a large guide sign. However, reducing the wind load in this manner may necessitate more frequent checks of the work zone in some regions during adverse weather conditions to correct any wind-related problems with the sign support systems. If local experience dictates that an unacceptable number of overturns are occurring when the sign support is properly ballasted for this wind speed, a higher wind speed can be selected to minimize the associated maintenance. A higher wind speed can be accommodated through the proper sizing of sign support members and application of additional ballast.

## 2.4 POST ACTIVATION

Weakening of the post below the sign panel is typically desired in systems with multiple wood supports to facilitate fracture and release of the impacted post(s). Historically, steel post supports for guide signs use fuse plates to create hinge or release points below the sign panel that permit an impacted post to rotate out of the path of the vehicle. Wood support posts are typically weakened by saw cuts or drilling holes through the cross section of the post. A wood post weakened to facilitate fracture during vehicle impacts must retain sufficient strength to resist wind loads at the weakened location.

The researchers performed an analysis to help select a weakening hole size for the supports used in the skid-mounted sign support system based on the required moment capacity at the bottom of the sign panel. They selected a 1.5-inch diameter weakening hole for both the 4-inch × 4-inch and 4-inch × 6-inch support posts. The hole was drilled along the weak axis of the post perpendicular to the sign panel. As shown in Table 2.6, this size weakening hole provides approximately twice the required flexural capacity. Although the analysis indicates that use of a larger weakening hole is feasible, the smaller 1½-inch diameter hole will be easier to drill and provides a reasonable safety factor in the event the hole is drilled a little off center in the post.

**Table 2.6. Analysis Results for Post Weakening below Sign.**

<b>Post Grade</b>	<b>Post size</b>	<b>Sx Required, in<sup>3</sup></b>	<b>Max Hole Φ<sup>1</sup>, inches</b>	<b>Selected Hole Φ, inches</b>	<b>Sx Provided, in<sup>3</sup></b>
Grade 1	4 × 4	3.39	2.73	<b>1.50</b>	6.67
Grade 2	4 × 4	3.65	2.63	<b>1.50</b>	6.67
Grade 1	6 × 4	6.64	2.89	<b>1.50</b>	15.00
Grade 2	6 × 4	7.01	2.83	<b>1.50</b>	15.00

<sup>1</sup> Weakening hole along weak axis of post (perpendicular to sign panel)

In previous testing performed under this project to evaluate the impact performance of direct embedded wood support systems, it was observed that a fractured support post could rotate into the windshield of the impacting vehicle. To prevent this secondary contact, researchers looped a ¼-inch diameter restraining cable through the post at points above and below the weakening hole. The cable acts as a hinge and restricts rotation of the support toward the impacting vehicle, allowing it to pass underneath the sign panel without contact with the windshield or roof. This same treatment is recommended for use in the skid-mounted sign support system.

## 2.5 SIGN SUBSTRATE CONNECTION

TxDOT uses extruded aluminum signs almost exclusively on its permanent roadside guide signs. Plywood is a commonly used substrate for smaller temporary sign support systems. At the request of the PMC, both extruded aluminum and plywood substrates were considered in the design of the temporary large guide sign support systems. This gives contractors more flexibility to choose the most economical sign substrate based on factors such as availability,

material cost, fabrication cost, weight (handling), durability, etc. If an existing guide sign is being relocated, it would likely be cost-effective to use the existing extruded aluminum sign panel and simply remount it on the skid-mounted supports. If a new sign is being deployed in the work zone, it may be more economical to use a plywood sign substrate.

For the skid-mounted sign support system, a connection detail has been developed that can be used for either sign substrate. The connection consists of two  $\frac{3}{8}$ -inch diameter  $\times$  6  $\frac{1}{2}$ -inch long A307 hex head bolts (one on each side of the support post) and an a 1 $\frac{1}{2}$ -inch wide  $\times$  5 $\frac{1}{2}$ -inch long clamp plate fabricated out of 11 gauge sheet steel. For the extruded aluminum sign substrate, the head of the bolts are inserted into a channel fabricated into the back side of each extruded aluminum panel section. One bolt is used on each side of the post at each connection location. The ends of each bolt are inserted through the clamp plate that is positioned on the back side of the post, and secured with a washer and nut. When the connection bolts are tightened, the extruded aluminum sign panel is clamped to the wood support posts.

The same connection detail can be used for a plywood sign substrate. In this case, the connection bolts pass through holes drilled through the plywood substrate on each side of the support post. A washer can be used under the head of the hex head bolts. As with the extruded aluminum, the ends of each bolt are inserted through the clamp plate that is positioned on the back side of the post and secured with a washer and nut. When the connection bolts are tightened, the plywood sign panel is clamped to the wood support posts.

Due to the reduced number of clamps on the plywood substrate connection, and the possibility of bolts pulling through the plywood substrate, the researchers consider this design less critical from an impact standpoint compared to the extruded aluminum sign panels. They believe that the plywood substrate has an increased chance of releasing from the wood sign supports during a vehicular impact errant. Therefore, the research team conducted the compliance testing of the skid-mounted sign support system with an extruded aluminum sign panel.

## 2.6 CRASHWORTHINESS

In addition to being able to accommodate service loads, sign support systems placed within the clear zone on a highway must also be crashworthy. The design impact requirements for roadside hardware are performance based and consist of a prescribed crash test matrix with impact conditions defined in terms of vehicle type, vehicle mass, impact speed, and impact angle. Current guidance on the impact performance evaluation of sign support structures is contained in the AASHTO *MASH* (2). According to *MASH*, a matrix of three tests is recommended to evaluate the crashworthiness of a temporary sign support system. The full-scale crash testing of the temporary skid-mounted, large guide sign support system was performed and evaluated following the *MASH* guidelines.

In an earlier task under this project, a direct embedded wood sign support system was successfully crash tested. In the testing, the vehicles simultaneously impacted two 6-inch  $\times$  8-inch wood supports with 4-inch diameter weakening holes. This full-scale crash testing established an upper limit on wood post strength. Therefore, various combinations of 4-inch  $\times$  6-inch or 4-inch  $\times$  4-inch posts can be considered acceptable in this same configuration, provided

that their combined flexural strength (as defined by section modulus) is less than or equal to the combined strength of the dual, weakened 6-inch × 8-inch posts.

Engineering calculations were used as the basis for selection of support post configurations for the skid-mounted system. A 2-year recurrence interval (i.e., 48-mph design wind speed) was assumed for the analysis to establish the required number and spacing of support posts for the post sizes of interest, namely 4-inch × 6-inch and 4-inch × 4-inch posts. The spacing of the posts is used in combination with the width of the design test vehicles to establish how many posts will be impacted. The combined shear and moment capacity for the number of posts impacted can then be determined and compared to the limit values established by the dual 6-inch × 8-inch posts to establish an initial design of the skid-mounted system for full-scale crash testing.

Table 2.7 show the results of the analyses for an 8-ft tall × 16-ft wide (128 ft<sup>2</sup>) sign. As shown in the table, three 4-inch × 6-inch, Grade 2 posts would fall within the path of the impacting vehicle. The combined moment (bending) capacity for three unmodified 4-inch × 6-inch Grade 2 posts is 9.98 kip-ft, which is less than the combined flexural capacity of the dual, weakened 6-inch × 8-inch posts that were successfully crash-tested in the direct embedded system. The shear capacity of the three unmodified 4-inch × 6-inch Grade 2 posts is 8.62 kips, which is approximately 20 percent greater than the shear capacity of the dual, weakened 6-inch × 8-inch posts. In the opinion of the researchers, the failure mechanism of wooden sign posts typically occurs in flexure rather than shear. Further, although the strength of the dual 6-inch × 8-inch posts are being used as a design limit, the results of the testing of the direct embedded wood sign support system indicate that some additional post capacity can be accommodated from an impact performance standpoint.

For these reasons, it was recommended to test the skid-mounted temporary guide sign system with three unmodified 4-inch × 6-inch, Grade 2 posts in the path of the impacting vehicle. If the test is successful, the use of unmodified posts will simplify and reduce fabrication cost. In addition, the three unmodified 4-inch × 6-inch Grade 2 posts have a greater flexural capacity than the other post options considered and, therefore, a successful test of the recommended configuration will establish the acceptance of the other less-critical post configurations.

**Table 2.7. Combined Post Impact Capacity (2-Year Recurrence Interval).**

Comparison of Post Capacity (48 mph - Appendix C Method)							
Post Specifications				With Hole		Without Hole	
Grade	Post size	# Impacted	Hole Size	Kip*ft	Kips	Kip*ft	Kips
			in	Bending Capacity	Shear Capacity	Bending Capacity	Shear Capacity
Grade 1	4x4	3				6.56	6.38
Grade 2	4x4	4				7.09	7.66
Grade 1	6x4	2				8.78	5.75
Grade 2	6x4	3				9.98	8.62
<b>Grade 1</b>	<b>6x8</b>	<b>2</b>	<b>4</b>	<b>14.36</b>	<b>7.02</b>		
				These are totals for Impacted Posts			

## 2.7 RECOMMENDED DESIGN

The recommended size and number of support posts will vary based on the size of the sign panel being considered. The size of the sign panel is based on the information being presented to the motorists. Obviously, resources are insufficient to crash-test all possible design configurations. The approach followed for the evaluation of the skid-mounted sign support system was to select a critical configuration from among those considered practical. A successful test of this critical configuration (i.e., support size, grade, and spacing) will provide acceptance for other less-critical configurations.

Recommended design details for a skid-mounted support system for an 8-ft × 16-ft (128 ft<sup>2</sup>) extruded aluminum sign panel were reviewed with the PMC. The PMC reduced the overall size of the sign to 96 ft<sup>2</sup> based on consideration of application need and practicality of ballast requirements. Texas A&M Transportation Institute (TTI) researchers modified the design and ballast accordingly, and received approval from the PMC and Project Manager to proceed with evaluation of the impact performance of the system through full-scale crash testing. Details of the sign support system and the full-scale crash tests are presented in the following chapters of this report.



## CHAPTER 3. *MASH* CRASH TEST REQUIREMENTS AND PROCEDURES

### 3.1 TEST FACILITY

The full-scale crash tests reported herein were performed at the Texas Transportation Institute Proving Ground, an International Standards Organization 17025 accredited laboratory with American Association for Laboratory Accreditation (A2LA) Mechanical Testing certificate 2821.01. The full-scale crash tests were performed according to TTI Proving Ground quality procedures, and according to *MASH* guidelines and standards.

The TTI Proving Ground is a 2000-acre complex of research and training facilities located 10 miles northwest of the main campus of Texas A&M University. The site, formerly a United States Army Air Corps base, has large expanses of concrete runways and parking aprons well-suited for experimental research and testing in the areas of vehicle performance and handling, vehicle-roadway interaction, durability and efficacy of highway pavements, and safety evaluation of roadside safety hardware. The site selected for placement and testing of the skid-mounted sign supports evaluated under this project was an out-of-service apron. The apron consists of an unreinforced jointed-concrete pavement in 12.5-ft × 15-ft blocks nominally 6 inches deep. The apron was built in 1942 and the joints have some displacement, but are otherwise flat and level.

### 3.2 CRASH TEST MATRIX

The full-scale crash testing performed under this project was in accordance with the guidelines and procedures set forth in *MASH*. The recommended matrix for evaluating breakaway support structures to test level 3 (TL-3) consists of three tests:

- ***MASH* Test 3-70:** An 1100C (2425 lb/1100 kg) vehicle impacting the device at a nominal impact speed of 19 mph and critical impact angle (CIA) judged to have the greatest potential for test failure. This test evaluates the kinetic energy required to activate the breakaway, fracture, or yielding mechanism of the supports.
- ***MASH* Test 3-71:** An 1100C (2425 lb/1100 kg) vehicle impacting the device at a nominal impact speed of 62 mph and CIA judged to have the greatest potential for test failure. This test evaluates the behavior of the device during high-speed impact with a small vehicle.
- ***MASH* Test 3-72:** A 2270P (5000 lb/2270 kg) vehicle impacting the device at a nominal impact speed of 62 mph and CIA judged to have the greatest potential for test failure. This test evaluates the behavior of the device during high-speed impact with a pickup truck.

The crash tests on the skid-mounted wood support systems were performed using an impact angle of zero degrees. This permitted multiple support posts to be simultaneously impacted, thus providing the most critical case for evaluating occupant risk and secondary contact of the fractured supports with the vehicle.

The crash test and data analysis procedures were in accordance with guidelines presented in *MASH*. A summary of these procedures is provided below.

### **3.3 EVALUATION CRITERIA**

The crash tests were evaluated in accordance with applicable criteria presented in *MASH*. The performance of sign supports is judged primarily on the basis of structural adequacy and occupant risk. Structural adequacy is judged according to the ability of the sign support to activate in a predictable manner by breaking away, fracturing, or yielding. Occupant risk is evaluated based on factors such as occupant compartment deformation, intrusion of structural components into the vehicle windshield, vehicle stability, and occupant impact velocity. The appropriate safety evaluation criteria from Table 5-1 of *MASH* were used to evaluate the crash tests reported herein. These criteria are listed in further detail under the assessment of the crash tests.

### **3.4 VEHICLE TOW AND GUIDANCE PROCEDURES**

Each test vehicle was towed into the test installation using a steel cable guidance and reverse tow system. A steel cable for guiding the test vehicle was tensioned along the path, anchored at each end, and threaded through an attachment to the front wheel of the test vehicle. An additional steel cable was connected to the test vehicle, passed around a pulley near the impact point, through a pulley on the tow vehicle, and then anchored to the ground such that the tow vehicle moved away from the test site. A 2:1 speed ratio between the test and tow vehicle existed with this system. Just prior to impact with the installation, the system released the test vehicle. The vehicle remained unrestrained and freewheeling (i.e., no steering or braking inputs) until it cleared the immediate area of the test site, after which the brakes were activated, if needed, to bring it to a safe and controlled stop.

### **3.5 DATA ACQUISITION SYSTEMS**

#### **3.5.1 Vehicle Instrumentation and Data Processing**

Each test vehicle was instrumented with a self-contained, on-board data acquisition system. The signal conditioning and acquisition system is a 16-channel, Tiny Data Acquisition System (TDAS) Pro manufactured by Diversified Technical Systems, Inc. The accelerometers measure the x, y, and z axis of vehicle acceleration, and are a strain-gauge type with linear millivolt output proportional to acceleration. Angular rate sensors are ultra-small, solid state units designed for crash test service; they measure vehicle roll, pitch, and yaw rates. The TDAS Pro hardware and software conform to the latest SAE J211, Instrumentation for Impact Test. Each of the 16 channels is capable of providing precision amplification, scaling, and filtering based on transducer specifications and calibrations. During the test, data are recorded from each channel at a rate of 10,000 values per second with a resolution of one part in 65,536. Once recorded, the data are backed up inside the unit by internal batteries should the primary battery cable be severed. Initial contact of the pressure switch on the vehicle bumper provides a time zero mark as well as initiating the recording process. After each test, the data are downloaded from the TDAS Pro unit into a laptop computer at the test site. The Test Risk Assessment Program (TRAP) software then processes the raw data to produce detailed reports of the test

results. Each of the TDAS Pro units is returned to the factory annually for complete recalibration. Accelerometers and rate transducers are also calibrated annually with traceability to the National Institute for Standards and Technology. Acceleration data are measured with an expanded uncertainty of  $\pm 1.7$  percent at a confidence factor of 95 percent ( $k=2$ ).

TRAP uses the data from the TDAS Pro to compute occupant/compartiment impact velocities, time of occupant/compartiment impact after vehicle impact, and the highest 10-millisecond (ms) average ridedown acceleration. TRAP calculates change in vehicle velocity at the end of a given impulse period. In addition, maximum average accelerations over 50-ms intervals in each of the three directions are computed. For reporting purposes, the data from the vehicle-mounted accelerometers are filtered with a 60-Hz digital filter, and acceleration versus time curves for the longitudinal, lateral, and vertical directions are plotted using TRAP.

TRAP uses the data from the yaw, pitch, and roll rate transducers to compute angular displacement in degrees at 0.0001-s intervals, and then plots yaw, pitch, and roll versus time. These displacements are in reference to the vehicle-fixed coordinate system with the initial position and orientation of the vehicle-fixed coordinate systems being initial impact. Rate of rotation data is measured with an expanded uncertainty of  $\pm 0.7$  percent at a confidence factor of 95 percent ( $k=2$ ).

### **3.5.2 Anthropomorphic Dummy Instrumentation**

An Alderson Research Laboratories Hybrid II, 50<sup>th</sup> percentile male anthropomorphic dummy, restrained with lap and shoulder belts, was placed in the driver's position of each 1100C vehicle. The dummy was uninstrumented. Use of a dummy in the 2270P vehicle is optional according to *MASH*, and no dummy was used in the test with the 2270P vehicle.

### **3.5.3 Photographic Instrumentation and Data Processing**

Photographic coverage of each test included two high-speed cameras: one placed behind the installation at an angle and a second placed to have a field of view perpendicular to the path of the vehicle and aligned with the installation. A flashbulb activated by pressure-sensitive tape switches was positioned on the impacting vehicle to indicate the instant of contact with the installation, and was visible from each camera. The videos from these high-speed cameras were analyzed on a computer-linked motion analyzer to observe phenomena occurring during the collision and to obtain time-event, displacement, and angular data. A mini-DV camera and still cameras recorded and documented conditions of the test vehicle and installation before and after the test.



# CHAPTER 4. CRASH TESTING OF SKID-MOUNTED SUPPORT SYSTEM FOR TEMPORARY GUIDE SIGNS

## 4.1 TEST ARTICLE DESIGN AND CONSTRUCTION

The test installation involved an 8-ft tall  $\times$  12-ft wide (96 ft<sup>2</sup>) extruded aluminum sign panel supported by five 4-inch  $\times$  6-inch, Grade 2, SYP wood support posts at a mounting height of 7½ ft from the ground to the bottom of the sign panel. The mounting height was increased 6 inches beyond the standard mounting height of 7 ft to provide additional clearance for the pickup truck to pass beneath the sign panel and fractured supports in the event it climbs on top of the horizontal skids while traversing the system. Figure 4.1 shows overall details of the skid-mounted support system for temporary guide signs used for Test Nos. 467824-1 and 467824-2.

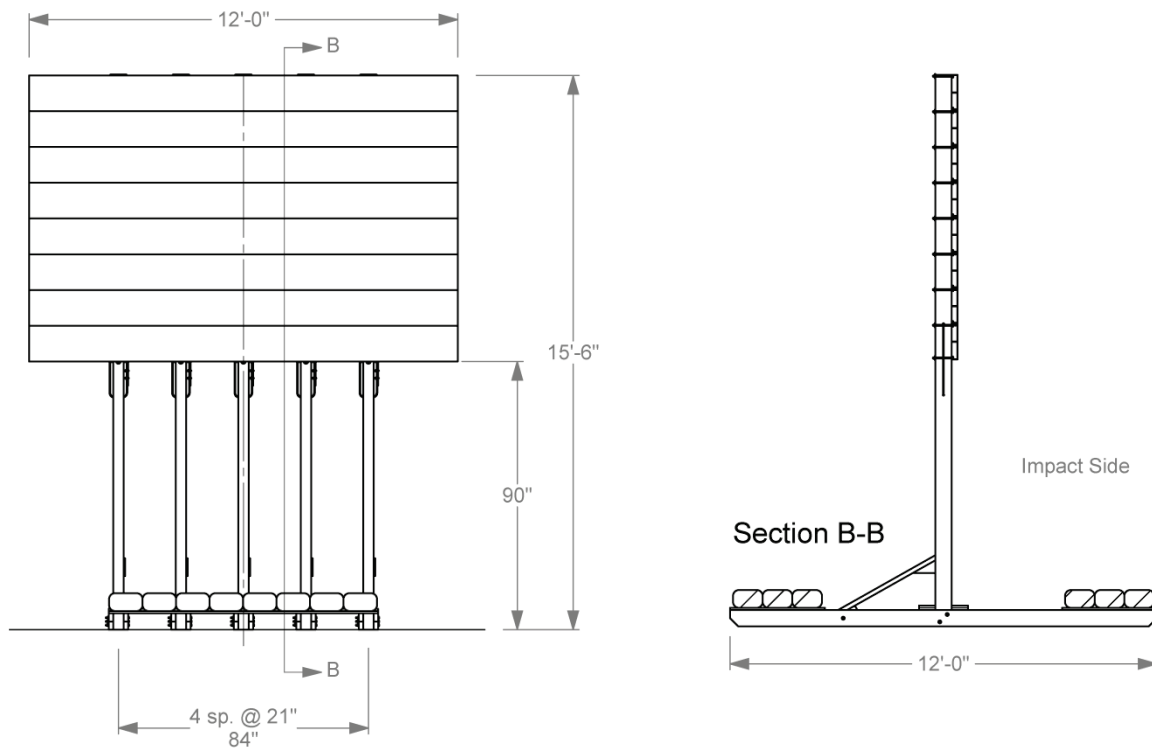

**Figure 4.1. Overall Details of the Skid-Mounted Support System Temporary Guide Sign.**

The spacing of the wood support posts was 21 inches center to center. This is closer than the spacing would be in a field installation of this sign, but was done to allow the test vehicle to simultaneously impact three of the five supports. Each of the vertical support posts were connected to a pair of 2-inch  $\times$  6-inch  $\times$  12-ft long horizontal skids using two ¾-inch diameter  $\times$  7½ inch long A307 hex head bolts. A 2-inch  $\times$  6-inch board was secured across the top of the horizontal skids against the front and back sides of the support posts using three 3-inch long, #9 deck screws per skid. A 40-inch long, 2-inch  $\times$  4-inch diagonal brace was attached to the back of each vertical support at a height of 24 inches using three 3-inch long, #9 deck screws per support. A ½-inch thick plywood gusset was attached to the vertical support and diagonal brace to reinforce the connection for wind loads applied to the back of the sign. The gusset plates were

attached to the support post using six 2-inch long, #8 deck screws and to the brace using four 2-inch long, #8 deck screws. The opposite end of the diagonal brace was attached to a 4-inch × 4-inch × 8-inch long brace block positioned between the skids. The brace block was attached to the skids using a  $\frac{3}{8}$ -inch diameter × 7½-inch long A307 hex head bolt. The diagonal brace was attached to the brace block using six 3-inch long, #9 deck screws.

A  $\frac{3}{4}$ -inch thick, 32-inch wide plywood deck was attached to the top of the skids on their leading and trailing ends to provide a platform for the sand bag ballast. The plywood deck was attached to each skid using 2-inch long, #8 deck screws. Fifty-six 40-lb sand bags were evenly distributed on the front and back plywood decks.

The extruded aluminum sign panel was comprised of eight 12-inches tall × 12-ft long × 0.078-inch thick extruded aluminum sections. Each section had a 2-inch tall continuous bolting flange channel running along the top and bottom edges, and a 2-inch tall × 0.118-inch thick stiffener plate running along the center. Each segment was attached to adjacent segments using  $\frac{3}{8}$ -inch diameter ×  $\frac{3}{4}$ -inch long A307 hex bolts nuts, and flat washers beginning 6 inches from each end and equally spaced at approximately 22 inches along the length of the sign. Each segment was attached to each support post using two  $\frac{3}{8}$ -inch diameter × 6 ½-inch long A307 hex head bolts (one on each side of the support post) and a 1½-inch wide × 5½-inch long clamp plate fabricated out of 11 gauge sheet steel. The heads of the mounting bolts bolting slid into the  $\frac{11}{16}$ -inch wide ×  $\frac{1}{4}$ -inch deep channels on the top and bottom edges of the sign panel segments.

A 1½-inch diameter hole was drilled along the weak axis of the support posts (i.e., perpendicular to the orientation of the sign panel) at a height of 7 ft above ground to facilitate fracture of the support below the sign panel. A  $\frac{7}{16}$ -inch diameter hole was drilled along the strong axis of the post (i.e., parallel to the orientation of the sign panel) 12 inches above and below the weakening hole. A  $\frac{1}{4}$ -inch diameter cable was looped through the holes and clamped. The cable is designed to restrict rotation of the support toward the impacting vehicle after it fractures through the weakening hole.

All dimensional lumber used in the construction of the sign support system was Grade 2, SYP produced to Sustainable Forestry Initiative (SFI) standards. Plywood was pressure treated grade. All lumber and plywood was pressure treated against rot and insects (chromated copper arsenate [CCA-C], “Wolmanized,” or equivalent).

Figure 4.2 shows photographs of the test installation prior to testing. Appendix A provides detailed construction drawings for the system, and Appendix B provides certification documents for the materials used in the construction of the system.

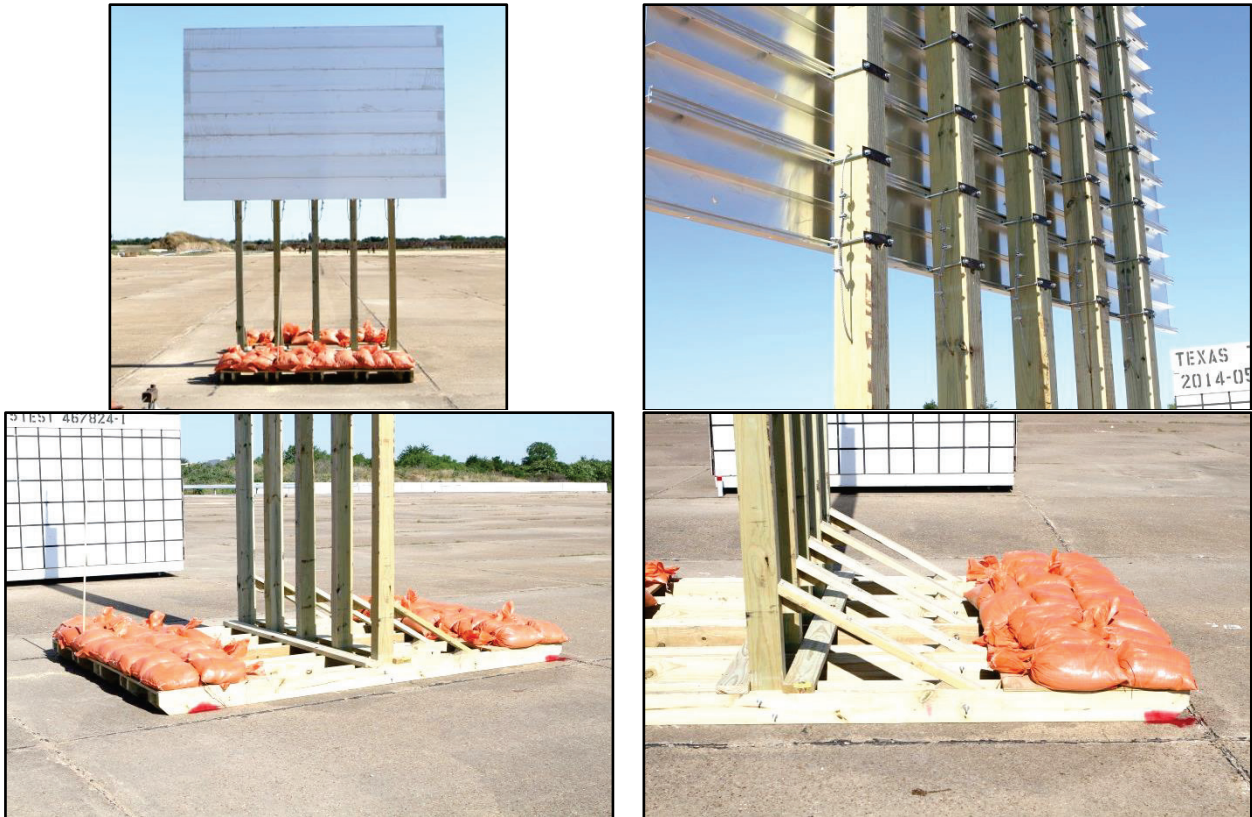

**Figure 4.2. Skid-Mounted Support System for Temporary Guide Signs before Test Nos. 467824-1 and 467824-2.**

## **4.2 MASH TEST 3-70 ON THE SKID-MOUNTED SUPPORT SYSTEM FOR TEMPORARY GUIDE SIGNS (TEST NO. 467824-1)**

### **4.2.1 Test Designation and Actual Impact Conditions**

*MASH* Test 3-70 involves an 1100C vehicle weighing 2420 lb  $\pm$  55 lb impacting the sign support at an impact speed of 19 mph  $\pm$  2.5 mph and a CIA of 0 degrees  $\pm$  1.5 degrees. The target impact point was the centerline of the vehicle aligned with the centerline of support post 2. The 2008 Kia Rio used for the test had a test inertial weight of 2440 lb, and the actual impact speed and angle were 19.1 mph and 0 degrees, respectively. The actual impact point was the centerline of the vehicle aligned with the centerline of support post 2 on the left side of the installation.

### **4.2.2 Test Vehicle**

A 2008 Kia Rio, shown in Figure 4.3, was used for the crash test. Test inertia weight of the vehicle was 2440 lb, and its gross static weight was 2605 lb. The height to the lower edge of the vehicle bumper was 8.0 inches, and the height to the upper edge of the bumper was 21.0 inches. Table C1 in Appendix C gives additional dimensions and information on the test vehicle. The vehicle was directed into the installation using a cable reverse tow and guidance system, and was released to be freewheeling and unrestrained just prior to impact.





**Figure 4.3. Vehicle before Test No. 467824-1.**

### **4.2.3 Weather Conditions**

The test was performed on the morning of May 15, 2014. Weather conditions at the time of testing were as follows: wind speed: 9 mph; wind direction: 211 degrees with respect to the vehicle (vehicle was traveling in a northerly direction); temperature: 65°F; and relative humidity: 58 percent.

### **4.2.4 Test Description**

The 2008 Kia Rio, traveling at an impact speed of 19.1 mph, impacted the skid-mounted sign support system at an impact angle of 0 degrees with the centerline of the vehicle aligned with the centerline of support post 2. At approximately 0.076 s, the front tires began to climb up onto the plywood platform atop the skids, and proceeded to plow through the sand bags. At 0.260 s, the vehicle simultaneously impacted three of the 4 inch × 6 inch support posts. The sign support began to slide along with the vehicle at 0.288 s, and the sign support began to rotate clockwise at 0.300 s. Brakes on the vehicle were not applied, and the vehicle came to rest against the support posts at 1.320 s. Figure C1 in Appendix C show sequential photographs of the test period.

### **4.2.5 Damage to Test Installation**

Figure 4.4 shows damage to the skid-mounted sign support system after the test. Cracking was observed in the middle support near bumper level, but the support was not fractured. The right front corner of the skids was pushed forward 82 inches and left 2 inches. The right front corner of the skids was pushed forward 34 inches. The vehicle bumper was resting against support posts 1 through 3.

### **4.2.6 Vehicle Damage**

Figure 4.5 shows the minimal damage that the vehicle sustained during the test, which included a small indentation in the front bumper and the radiator. No measureable exterior crush occurred, and no occupant compartment deformation or intrusion was noted. Tables C2 and C3 of Appendix C show the exterior crush and occupant compartment measurements.



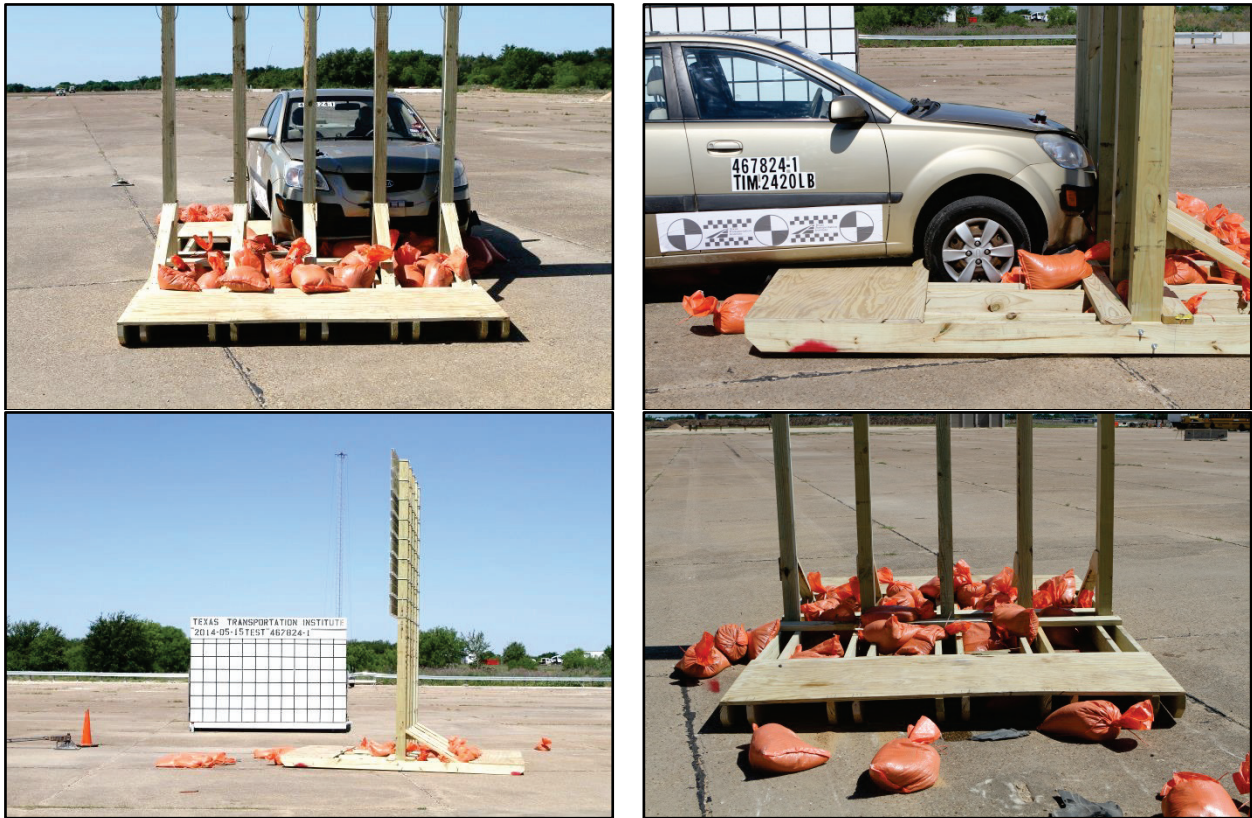

**Figure 4.4. Skid-Mounted Support System for Temporary Guide Signs after Test No. 467824-1.**



**Figure 4.5. Vehicle after Test No. 467824-1.**

#### **4.2.7 Occupant Risk Factors**

Data from the accelerometer located at the vehicle center of gravity were digitized for evaluation of occupant risk. In the longitudinal direction, the occupant impact velocity was 12.1 ft/s at 0.318 s, the highest 0.010-s occupant ridedown acceleration was 1.1 Gs from 0.318 to

0.328 s, and the maximum 0.050-s average acceleration was  $-3.1$  Gs between 0.266 and 0.316 s. In the lateral direction, the occupant impact velocity was 0.3 ft/s at 0.318 s, the highest 0.010-s occupant ridedown acceleration was 1.3 Gs from 0.465 to 0.475 s, and the maximum 0.050-s average was 0.9 Gs between 0.451 and 0.501 s. Theoretical Head Impact Velocity (THIV) was 13.4 km/h or 3.7 m/s at 0.318 s; Post-Impact Head Decelerations (PHD) was 1.5 Gs between 0.462 and 0.472 s; and Acceleration Severity Index (ASI) was 0.29 between 0.043 and 0.093 s. Figure 4.6 summarizes these data and other pertinent information from the test. In Appendix C, Figures C3 through C9 present the vehicle angular displacements and accelerations versus time traces.

#### 4.2.8 Assessment of Test Results

An assessment of the test based on applicable *MASH* safety evaluation criteria is provided below.

##### 4.2.8.1 Structural Adequacy

- B. *The test article should readily activate in a predictable manner by breaking away, fracturing, or yielding.*

Results: The skid-mounted wood post support system for temporary guide signs performed acceptably by sliding along with the vehicle. (PASS)

##### 4.2.8.2 Occupant Risk

- D. *Detached elements, fragments, or other debris from the test article should not penetrate or show potential for penetrating the occupant compartment, or present an undue hazard to other traffic, pedestrians, or personnel in a work zone.*

*Deformation of, or intrusions into, the occupant compartment should not exceed limits set forth in Section 5.3 and Appendix E of MASH (roof  $\leq 4.0$  inches; windshield =  $\leq 3.0$  inches; side windows = no shattering by test article structural member; wheel/foot well/toe pan  $\leq 9.0$  inches; forward of A-pillar  $\leq 12.0$  inches; front side door area above seat  $\leq 9.0$  inches; front side door below seat  $\leq 12.0$  inches; floor pan/transmission tunnel area  $\leq 12.0$  inches).*

Results: No detached elements, fragments, or other debris was present to penetrate or show potential for penetrating the occupant compartment, or to present an undue hazard to others. (PASS)

No occupant compartment deformation occurred. (PASS)

- F. *The vehicle should remain upright during and after collision. The maximum roll and pitch angles are not to exceed 75 degrees.*

Results: The 1100C vehicle remained upright during and after the collision event. Maximum roll and pitch angles were 8 degrees and 3 degrees, respectively. (PASS)

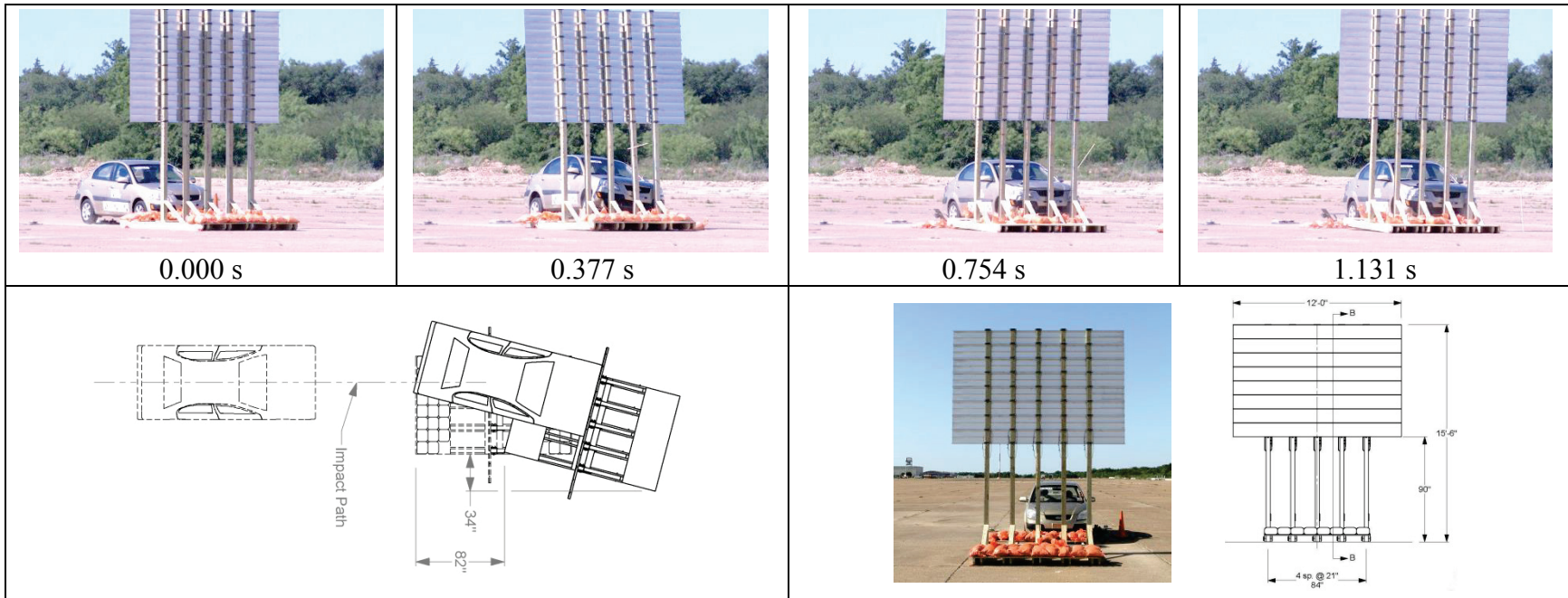

**General Information**

Test Agency ..... Texas A&M Transportation Institute (TTI)  
 Test Standard Test No. .... MASH Test 3-70  
 TTI Test No. .... 467824-1  
 Test Date ..... 2014-05-15

**Test Article**

Type ..... Sign Support  
 Name ..... Skid-Mounted Support System for  
 Temporary Guide Signs  
 Installation Mounting Height ..... 7.5 ft  
 Material or Key Elements ..... 8 ft x 12 ft extruded aluminum panel, five  
 4-inch x 6-inch wood supports on 2-inch x  
 6-inch skids, 7.5-ft mounting height

**Soil Type**

Concrete surface

**Test Vehicle**

Type/Designation ..... 1100C  
 Make and Model ..... 2008 Kia Rio  
 Curb ..... 2510 lb  
 Test Inertial ..... 2440 lb  
 Dummy ..... 165 lb  
 Gross Static ..... 2605 lb

**Impact Conditions**

Speed ..... 19.1 mph  
 Angle ..... 0 degrees  
 Location/Orientation ..... Head-on at post 2

**Exit Conditions**

Speed ..... Stopped  
 Angle ..... N.A.

**Occupant Risk Values**

Impact Velocity  
 Longitudinal ..... 12.1 ft/s  
 Lateral ..... 0.3 ft/s  
 Ridedown Accelerations  
 Longitudinal ..... 1.1 G  
 Lateral ..... 1.3 G  
 THIV ..... 3.7 m/s  
 PHD ..... 1.5 G  
 ASI ..... 0.29  
 Max. 0.050-s Average  
 Longitudinal ..... -3.1 G  
 Lateral ..... 0.9 G  
 Vertical ..... -1.0 G

**Post-Impact Trajectory**

Stopping Distance ..... 82 inches

**Vehicle Stability**

Maximum Yaw Angle ..... 9 degrees  
 Maximum Pitch Angle ..... 3 degrees  
 Maximum Roll Angle ..... 8 degrees  
 Vehicle Snagging ..... No  
 Vehicle Pocketing ..... No

**Test Article Debris Pattern**

Longitudinal ..... 82 inches  
 Lateral ..... 2 inches

**Vehicle Damage**

VDS ..... 12FD1  
 CDC ..... 12FLEW1  
 Max. Exterior Deformation ..... 0.5 inch  
 OCDI ..... FS000000  
 Max. Occupant Compartment  
 Deformation ..... None

**Figure 4.6. Summary of Results for MASH Test 3-70 on the Skid-Mounted Sign Support System for Temporary Guide Signs.**

H. Occupant impact velocities should satisfy the following:  
Longitudinal and Lateral Occupant Impact Velocity

<u>Preferred</u>	<u>Maximum</u>
10 ft/s	16.4 ft/s

Results: Longitudinal occupant impact velocity was 12.1 ft/s, and lateral occupant impact velocity was 0.3 ft/s. (PASS)

I. Occupant ridedown accelerations should satisfy the following:  
Longitudinal and Lateral Occupant Ridedown Accelerations

<u>Preferred</u>	<u>Maximum</u>
15.0 Gs	20.49 Gs

Results: Maximum longitudinal ridedown acceleration was 1.1 G, and maximum lateral ridedown acceleration was 1.3 G. (PASS)

#### 4.2.8.3 Vehicle Trajectory

N. Vehicle trajectory behind the test article is acceptable.

Result: The 1100C vehicle came to rest against the installation. (PASS)

### 4.3 MASH TEST 3-71 ON THE SKID-MOUNTED SUPPORT SYSTEM FOR TEMPORARY GUIDE SIGNS (TEST NO. 467824-2)

#### 4.3.1 Test Designation and Actual Impact Conditions

MASH Test 3-71 involves an 1100C vehicle weighing 2420 lb ± 55 lb impacting the sign support at a speed of 62 mph ± 2.5 mph and a CIA of 0 degrees ± 1.5 degrees. The target impact point was the centerline of the vehicle aligned with the centerline of support post 2. The 2008 Kia Rio used in the test had a test inertial weight of 2425 lb, and the actual impact speed and angle were 62.1 mph and 0 degrees, respectively. The actual impact point was the centerline of the vehicle aligned with the centerline of support post 2 on the left side of the sign support system.

#### 4.3.2 Test Vehicle

A 2008 Kia Rio, shown in Figure 4.7, was used for the crash test. The test inertia weight of the vehicle was 2425 lb, and the gross static weight was 2590 lb. The height to the lower edge of the vehicle bumper was 8.75 inches, and the height to the upper edge of the bumper was 21.0 inches. Table D1 in Appendix D gives additional dimensions and information on the vehicle. The vehicle was directed into the installation using a cable reverse tow and guidance system, and was released to be freewheeling and unrestrained just prior to impact.

#### 4.3.3 Weather Conditions

The test was performed on the afternoon of May 15, 2014. Weather conditions at the time of testing were as follows: wind speed: 8 mph; wind direction: 206 degrees with respect to the vehicle (vehicle was traveling in a northerly direction); temperature: 77°F; and relative humidity: 41 percent.





**Figure 4.7. Vehicle before Test No. 467824-2.**

#### **4.3.4 Test Description**

The 2008 Kia Rio, traveling at an impact speed of 62.1 mph, impacted the skid-mounted sign support system at an impact angle of 0 degrees with the centerline of the vehicle aligned with the centerline of support post 2. At approximately 0.046 s, the tires impacted the plywood platform on top of the skids. The car subsequently climbed on top of the plywood platform, plowed through the sand bags, and simultaneously impacted three support posts at 0.072 s. The diagonal brace on the back side of support post 3 fractured near the skids at 0.082 s, and at the top near the connection with the support post at 0.094 s. At 0.118 s, the skids began to slide forward, and at 0.138 s, support post 3 separated at the top connection. By 0.202 s, all of the support posts showed evidence of failure. The sign panel separated at the lower connection to support posts 1, 3, 4, and 5, and fell onto the roof of the vehicle. Brakes on the vehicle were not applied, and the vehicle came to rest 75.5 ft downstream of the impact location. Figures D1 and D2 in Appendix D show sequential photographs of the test period.

#### **4.3.5 Damage to Test Installation**

Figure 4.8 shows damage to the skid-mounted sign support system after the test. Support post 2 pulled out of the skids at the bottom and did not fracture below the sign. Support posts 1, 3, 4, and 5, fractured at below the sign panel. Support post 3 fractured at the skids. All debris traveled with the vehicle until the vehicle came to rest 75.5 ft downstream of the impact point.

#### **4.3.6 Vehicle Damage**

Figure 4.9 shows the damage that the vehicle sustained during the test, which included the front bumper, radiator and support, hood, left and right front fenders, left rear quarter panel, right front door, right rear quarter panel, and the trunk lid. The front of the vehicle was deformed inward 10 inches. The roof was pushed downward in the rear passenger area and the rear glass broke. Maximum occupant compartment deformation was 2.0 inches over the center of the rear passenger area. Tables D2 and D3 of Appendix D show the exterior crush and occupant compartment measurements.



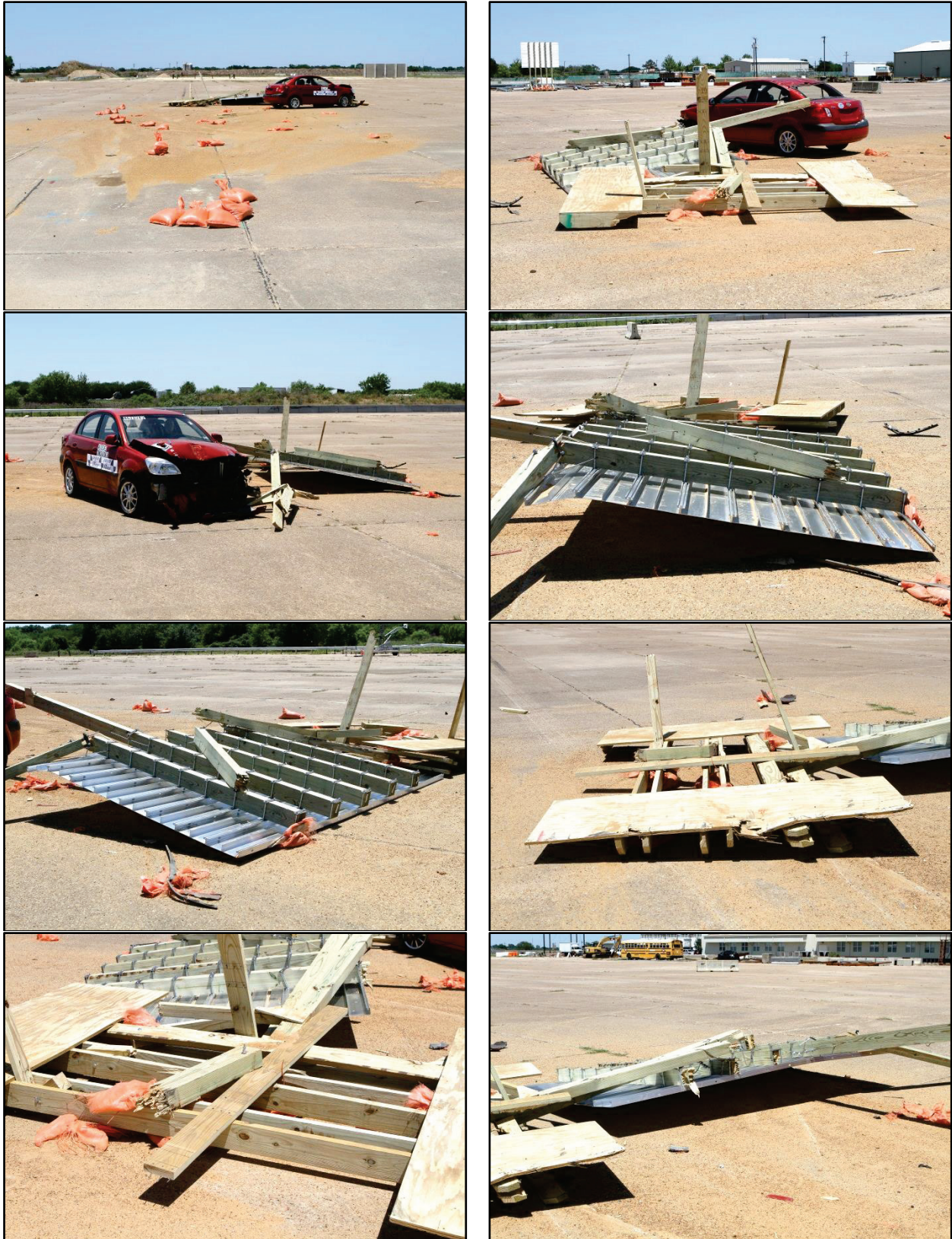

**Figure 4.8. Skid-Mounted Support System for Temporary Guide Signs after Test No. 467824-2.**

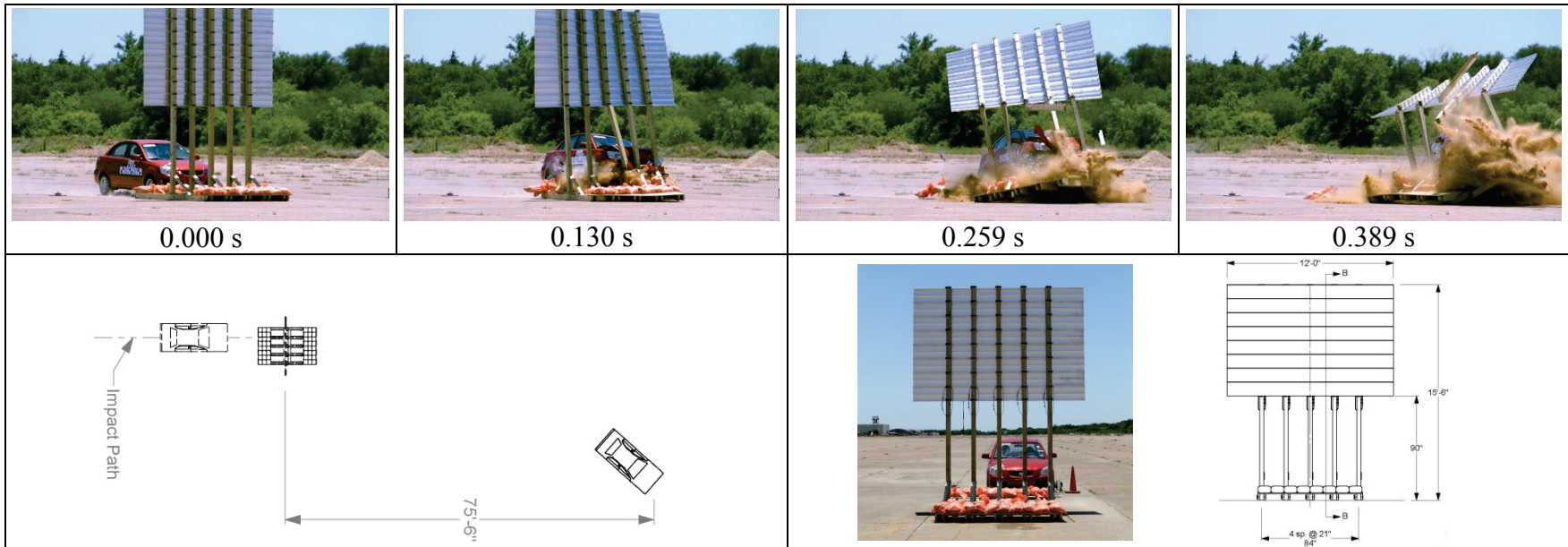



Figure 4.9. Vehicle after Test No. 467824-2.

#### 4.3.7 Occupant Risk Factors

Data from the accelerometer located at the vehicle center of gravity were digitized for evaluation of occupant risk. In the longitudinal direction, the occupant impact velocity was 30.8 ft/s at 0.125 s, the highest 0.010-s occupant ridedown acceleration was 4.9 Gs from 0.161 to 0.171 s, and the maximum 0.050-s average acceleration was -10.4 Gs between 0.008 and 0.058 s. In the lateral direction, the occupant impact velocity was 1.0 ft/s at 0.126 s, the highest 0.010-s occupant ridedown acceleration was 2.0 Gs from 0.708 to 0.718 s, and the maximum 0.050-s average was 1.4 Gs between 0.707 and 0.757 s. THIV was 34.0 km/h or 9.4 m/s at 0.125 s; PHD was 5.1 Gs between 0.161 and 0.171 s; and ASI was 1.13 between 0.035 and 0.085 s. Figure 4.10 summarizes these data and other pertinent information from the test. In Appendix D, Figures D3 through D9 present the vehicle angular displacements and accelerations versus time traces.



**General Information**

Test Agency ..... Texas A&M Transportation Institute (TTI)  
 Test Standard Test No. .... MASH Test 3-71  
 TTI Test No. .... 467824-2  
 Test Date ..... 2014-05-15

**Test Article**

Type ..... Sign Support  
 Name ..... Skid-Mounted Support System for Temporary Guide Signs  
 Installation Mounting Height ..... 7.5 ft  
 Material or Key Elements ..... 8 ft x 12 ft extruded aluminum panel, five 4-inch x 6-inch wood supports on 2-inch x 6-inch skids, 7.5-ft mounting height

**Soil Type**

Concrete surface

**Test Vehicle**

Type/Designation ..... 1100C  
 Make and Model ..... 2008 Kia Rio  
 Curb ..... 2402 lb  
 Test Inertial ..... 2425 lb  
 Dummy ..... 165 lb  
 Gross Static ..... 2590 lb

**Impact Conditions**

Speed ..... 62.1 mph  
 Angle ..... 0 degrees  
 Location/Orientation ..... Head-on at post 2

**Exit Conditions**

Speed ..... Stopped  
 Angle ..... N.A.

**Occupant Risk Values**

Impact Velocity  
 Longitudinal ..... 30.8 ft/s  
 Lateral ..... 1.0 ft/s  
 Ridedown Accelerations  
 Longitudinal ..... 4.9 G  
 Lateral ..... 2.0 G  
 THIV ..... 9.4 m/s  
 PHD ..... 5.1 G  
 ASI ..... 1.13  
 Max. 0.050-s Average  
 Longitudinal ..... -10.4 G  
 Lateral ..... 1.4 G  
 Vertical ..... -6.5 G

**Post-Impact Trajectory**

Stopping Distance ..... 75.5 ft

**Vehicle Stability**

Maximum Yaw Angle ..... 58 degrees  
 Maximum Pitch Angle ..... 17 degrees  
 Maximum Roll Angle ..... 13 degrees  
 Vehicle Snagging ..... No  
 Vehicle Pocketing ..... No

**Test Article Debris Pattern**

Longitudinal ..... 75.5 ft  
 Lateral ..... 15.0 ft

**Vehicle Damage**

VDS ..... 12FD5  
 CDC ..... 12FLEW5  
 Max. Exterior Deformation ..... 0.5 inch  
 OCDI ..... FS0200000  
 Max. Occupant Compartment Deformation ..... 2.0 inches

**Figure 4.10. Summary of Results for MASH Test 3-71 on the Skid-Mounted Support System for Temporary Guide Signs with Five Support Posts.**



### 4.3.8 Assessment of Test Results

An assessment of the test based on the applicable *MASH* safety evaluation criteria is provided below.

#### 4.3.8.1 Structural Adequacy

B. *The test article should readily activate in a predictable manner by breaking away, fracturing, or yielding.*

Results: Several of the wood support posts fractured below the sign panel and the system slid forward with the vehicle. (PASS)

#### 4.3.8.2 Occupant Risk

D. *Detached elements, fragments, or other debris from the test article should not penetrate or show potential for penetrating the occupant compartment, or present an undue hazard to other traffic, pedestrians, or personnel in a work zone.*

*Deformation of, or intrusions into, the occupant compartment should not exceed limits set forth in Section 5.3 and Appendix E of MASH (roof  $\leq 4.0$  inches; windshield =  $\leq 3.0$  inches; side windows = no shattering by test article structural member; wheel/foot well/toe pan  $\leq 9.0$  inches; forward of A-pillar  $\leq 12.0$  inches; front side door area above seat  $\leq 9.0$  inches; front side door below seat  $\leq 12.0$  inches; floor pan/transmission tunnel area  $\leq 12.0$  inches).*

Results: The sign panel and fractured sections of posts fell on the vehicle roof, resulting in 2.0 inches of deformation into the occupant compartment over the rear passenger area. (PASS)

F. *The vehicle should remain upright during and after collision. The maximum roll and pitch angles are not to exceed 75 degrees.*

Results: The 1100C vehicle remained upright during and after the collision event. Maximum roll and pitch angles were 13 degrees and 17 degrees, respectively. (PASS)

H. *Occupant impact velocities should satisfy the following:*

*Longitudinal and Lateral Occupant Impact Velocity*

<u>Preferred</u>	<u>Maximum</u>
10 ft/s	16.4 ft/s

Results: Longitudinal occupant impact velocity was 30.8 ft/s, and lateral occupant impact velocity was 1.0 ft/s. (FAIL)

I. *Occupant ridedown accelerations should satisfy the following:*

*Longitudinal and Lateral Occupant Ridedown Accelerations*

<u>Preferred</u>	<u>Maximum</u>
15.0 Gs	20.49 Gs

Results: Maximum longitudinal ridedown acceleration was 4.9 G, and maximum lateral ridedown acceleration was 2.0 G. (PASS)

#### 4.3.8.3 Vehicle Trajectory

*N. Vehicle trajectory behind the test article is acceptable.*

Result: The 1100C vehicle came to rest 75.5 ft behind the installation. (PASS)

### 4.4 DESIGN MODIFICATIONS

After analyzing the unacceptable high-speed test, TTI research engineers developed several design modifications to improve impact performance of the freestanding, skid-mounted support system for large guide signs. During analysis, the researchers noted that the vehicle experienced a significant force impulse when it encountered the plywood platform that ties the skids together and provides a uniform platform for the application of the sand bag ballast. To reduce the profile and, hence, the initial impulse applied to the vehicle, the plywood deck was moved to the bottom of the skids and the sand bag ballast was inserted between the skids. Since the plywood deck only needed to contain rather than support the ballast, its thickness was reduced from  $\frac{3}{4}$  inch to  $\frac{1}{2}$  inch.

The ends of the skids were tapered to help avoid any undercarriage snagging as they are traversed by the vehicle. Additionally, the researchers removed the 2-inch  $\times$  6-inch boards that were placed across the skids adjacent to the support posts to help develop moment capacity at the end of the support to accommodate wind loads. The team replaced these boards with support blocks inside the each skid on both sides of the support post. This replacement achieves the same desired behavior for resisting wind load, but eliminates direct contact with the 2  $\times$  6 members as the vehicle travels through the system.

In the high-speed test, the support posts did not fracture at bumper height as desired. This was due in part to the tendency of the system to slide forward and in part to the constraint added by the diagonal brace and gusset plate that reinforced the support to accommodate wind loads applied to the back side of the sign panel. To facilitate fracturing of the supports posts, the researchers incorporated 2-inch diameter weakening holes along the strong axis of the support posts (i.e., parallel to the orientation of the sign panel) at two locations: just above the top of the skids and at a height of 23 inches above ground, which correspond to the location of the diagonal braces that are attached to the support posts. These holes help weaken and promote controlled fracture of the support members without significantly decreasing the wind load capacity of the supports.

To further assist with the fracture of the support near bumper height of the vehicle, the gusset plate that connected the support to the diagonal brace was removed. This gusset was initially included to help resist wind loads applied to the back side of the sign, which otherwise would be resisted by only three wood screws when the diagonal brace was placed in tension. To help resist wind loads applied to the back of the sign, a second diagonal brace was added between the skids and the front face of each support post. Thus, one of the braces is placed in compression to resist wind loads regardless of the direction of the wind. The design intent is that the braces on the impact side will be fractured or pulled out of the support posts prior to the vehicle impacting the support posts. Removal of the gusset plate and the addition of the weakening hole will cause the support post to fracture more readily. Once the support post has

fractured, it is anticipated that the back side diagonal brace that is connected at the same height as the weakening hole will be readily released.

The final design change was to space the support members such that only two supports are in the path of the small car (note that there will still be three supports in the path of the pickup truck). This will help the small car fracture the supports as designed. A detailed analysis of the braced support post was performed, and it was concluded that the modified support system will still accommodate the 96 ft<sup>2</sup> sign area that the PMC had chosen as a practical maximum for this application. Figure 4.11 presents the details of the modified design for the freestanding, skid-mounted support system for large guide signs. Appendix E contains detailed drawings of the revised system, and Appendix F provides certification documents for the materials used.

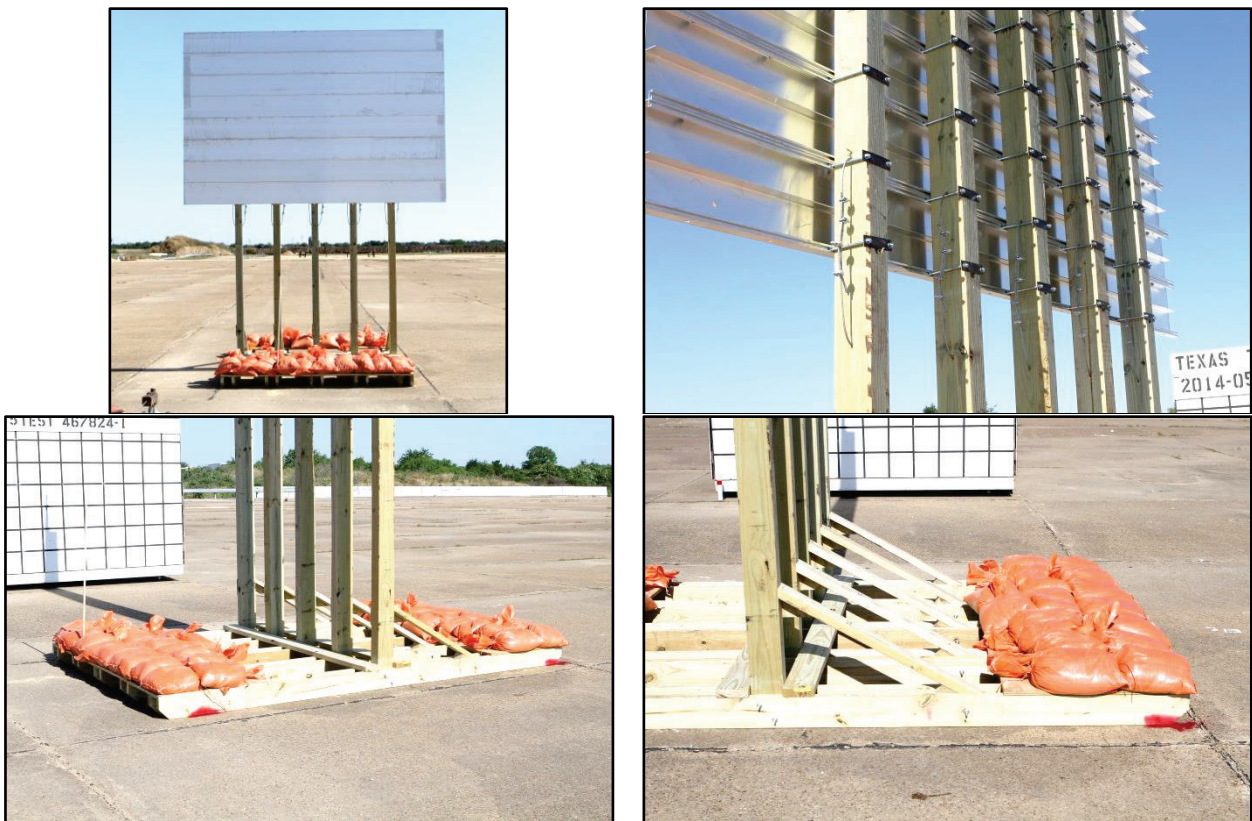

**Figure 4.11. Modified Skid-Mounted Support System for Temporary Guide Signs before Test Nos. 467824-3 and 467824-4.**

TTI researchers subjected the modified design to full-scale crash testing on May 30, 2014. The test matrix consisted of two tests: test 3-71 (high-speed small car test) and test 3-72 (high-speed pickup truck test). The researchers opined that the low-speed car test (Test 3-70) did not need to be rerun. During the low-speed test, the entire system was pushed forward and came to rest with the vehicle. Since the weight of the modified system did not increase, the deceleration of the small car will not increase. In the event the weakened support posts in the modified design fracture on impact, it will only reduce the deceleration on the small car by limiting the distance the entire system is pushed forward. This, in turn, will reduce the occupant impact velocity, which is the critical parameter for the slow-speed impact.

## 4.5 MASH TEST 3-71 ON THE MODIFIED SKID-MOUNTED SUPPORT SYSTEM FOR TEMPORARY GUIDE SIGNS (TEST NO. 467824-4)

### 4.6.1 Test Designation and Actual Impact Conditions

MASH Test 3-71 involves an 1100C vehicle weighing 2420 lb  $\pm$  55 lb impacting the sign support at a speed of 62 mph  $\pm$  2.5 mph and a CIA of 0 degrees  $\pm$  1.5 degrees. The target impact point was the centerline of the vehicle aligned with the centerline between support posts 1 and 2. The 2008 Kia Rio used in the test had a test inertial weight of 2440 lb, and the actual impact speed and angle were 63.1 mph and 0 degrees, respectively. The actual impact point was the centerline of the vehicle aligned with the centerline between the two supports on the right side of the sign support system.

### 4.6.2 Test Vehicle

A 2008 Kia Rio, shown in Figure 4.12, was used for the crash test. The test inertia weight of the vehicle was 2440 lb, and the gross static weight was 2605 lb. The height to the lower edge of the vehicle bumper was 8.0 inches, and the height to the upper edge of the bumper was 21.0 inches. Table G1 in Appendix G gives additional dimensions and information on the vehicle. The vehicle was directed into the installation using a cable reverse tow and guidance system, and was released to be freewheeling and unrestrained just prior to impact.



Figure 4.12. Vehicle before Test No. 467824-4.

### 4.6.3 Weather Conditions

The test was performed on the afternoon of May 30, 2014. Weather conditions at the time of testing were as follows: wind speed: 2 mph; wind direction: 28 degrees with respect to the vehicle (vehicle was traveling in a northerly direction); temperature: 76°F; and relative humidity: 80 percent.

### 4.6.4 Test Description

The 2008 Kia Rio, traveling at an impact speed of 63.1 mph, impacted the skid-mounted sign support system at an impact angle of 0 degrees with the centerline of the vehicle aligned with the centerline between support posts 1 and 2. At approximately 0.018 s, the tires began to ride up



on the skids and plow through the sand bags placed between the skids. At 0.047 s, the vehicle impacted the two support posts. At 0.052 s, support post 1 fractured midway between the diagonal brace and the skids, and support post 2 fractured near the the skids. Support post 1 fractured below the sign panel as designed at 0.055 s, and support post 2 fractured below the sign panel at 0.060 s. As the vehicle continued forward, the diagonal braces on support posts 1 and 2 separated from the support posts and skids and traveled in front of the vehicle. The fractured support posts rotated away from the vehicle and remained connected to the sign panel through the restraining cables. At 0.090 s, the vehicle lost contact with the support posts while traveling at a speed of 59.9 mph. By 0.263 s, the vehicle lost contact with the skids and was traveling at a speed of 56.6 mph. Brakes on the vehicle were applied 2.5 s after impact, and the vehicle came to rest 345 ft behind the initial impact location. Figure G1 in Appendix G shows sequential photographs of the test period.

#### 4.6.5 Damage to Test Installation

Figure 4.13 shows damage to the skid-mounted sign support system after the test. Support posts 1 and 2 fractured just below the sign panel and near the skids as designed. The fractured support posts remained attached to the sign panel by the restraining cables. The sign support system remained in place and upright, with the two remaining support posts bolstering the extruded aluminum sign panel. The diagonal support braces came to rest 165 ft downstream of impact along the path of the vehicle. The vehicle came to rest 345 ft downstream of the impact point.

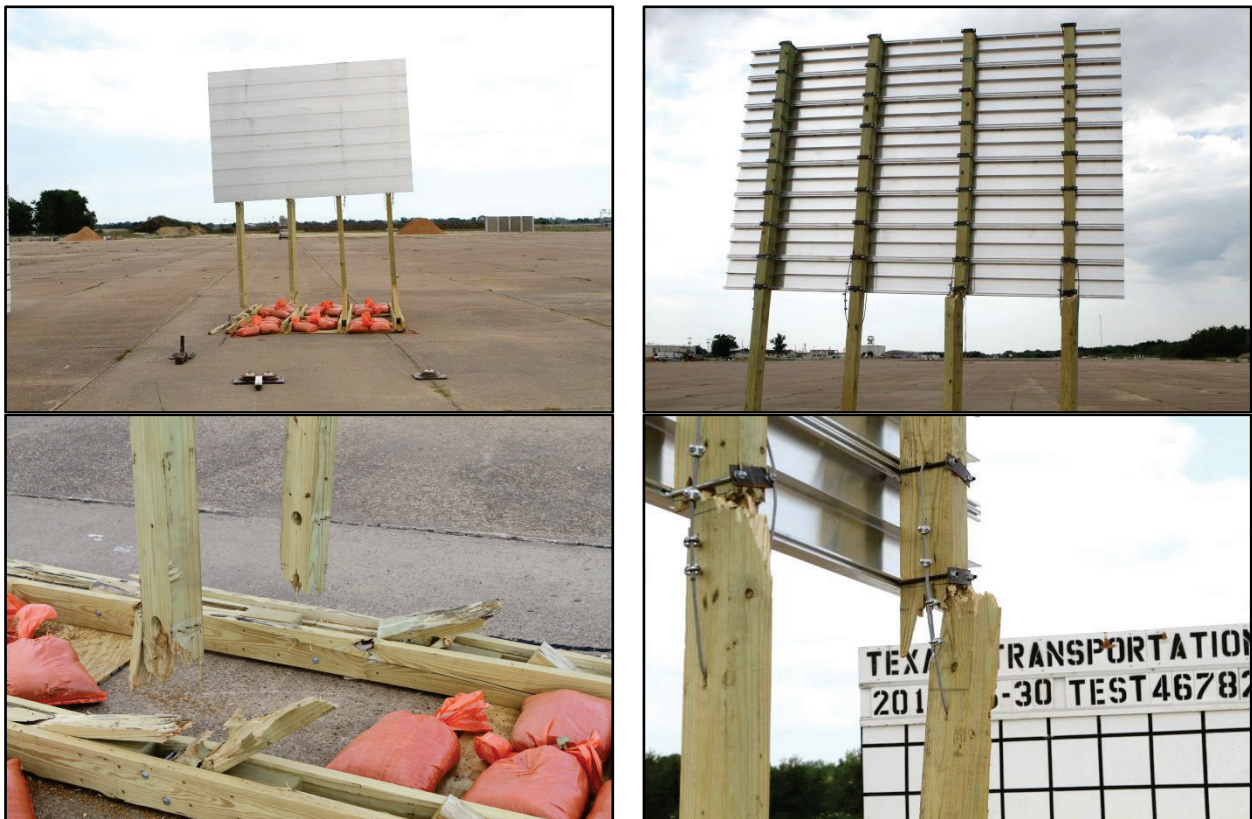

**Figure 4.13. Modified Skid-Mounted Support System after Test No. 467824-4.**

#### 4.6.6 Vehicle Damage

Figure 4.14 shows the damage that the vehicle sustained during the test, which included only cosmetic damage in the form of scratches to the front bumper. No measureable exterior crush to the vehicle was noted. No occupant compartment deformation occurred. Tables G2 and G3 in Appendix G give exterior crush and occupant compartment measurements.



Figure 4.14. Vehicle after Test No. 467824-4.

#### 4.6.7 Occupant Risk Factors

Data from the accelerometer located at the vehicle center of gravity were digitized for evaluation of occupant risk. In the longitudinal direction, the occupant impact velocity was 7.9 ft/s at 0.322 s, the highest 0.010-s occupant ridedown acceleration was 0.6 Gs from 0.626 to 0.636 s, and the maximum 0.050-s average acceleration was  $-3.7$  Gs between 0.039 and 0.089 s. In the lateral direction, no occupant impact occurred, the highest 0.010-s occupant ridedown acceleration was 1.0 Gs from 0.687 to 0.697 s, and the maximum 0.050-s average was 0.8 Gs between 0.667 and 0.717 s. THIV was 8.5 km/h or 2.4 m/s at 0.322 s; PHD was 1.0 Gs between 0.687 and 0.697 s; and ASI was 0.33 between 0.056 and 0.106 s. Figure 4.15 summarizes these data and other pertinent information from the test. In Appendix G, Figures G3 through G9 present the vehicle angular displacements and accelerations versus time traces.

#### 4.6.8 Assessment of Test Results

An assessment of the test based on the applicable *MASH* safety evaluation criteria is provided below.

##### 4.6.8.1 Structural Adequacy

*B. The test article should readily activate in a predictable manner by breaking away, fracturing, or yielding.*

Results: The skid-mounted wood post support system for temporary guide signs fractured below the sign panel and at the skids as designed. (PASS)

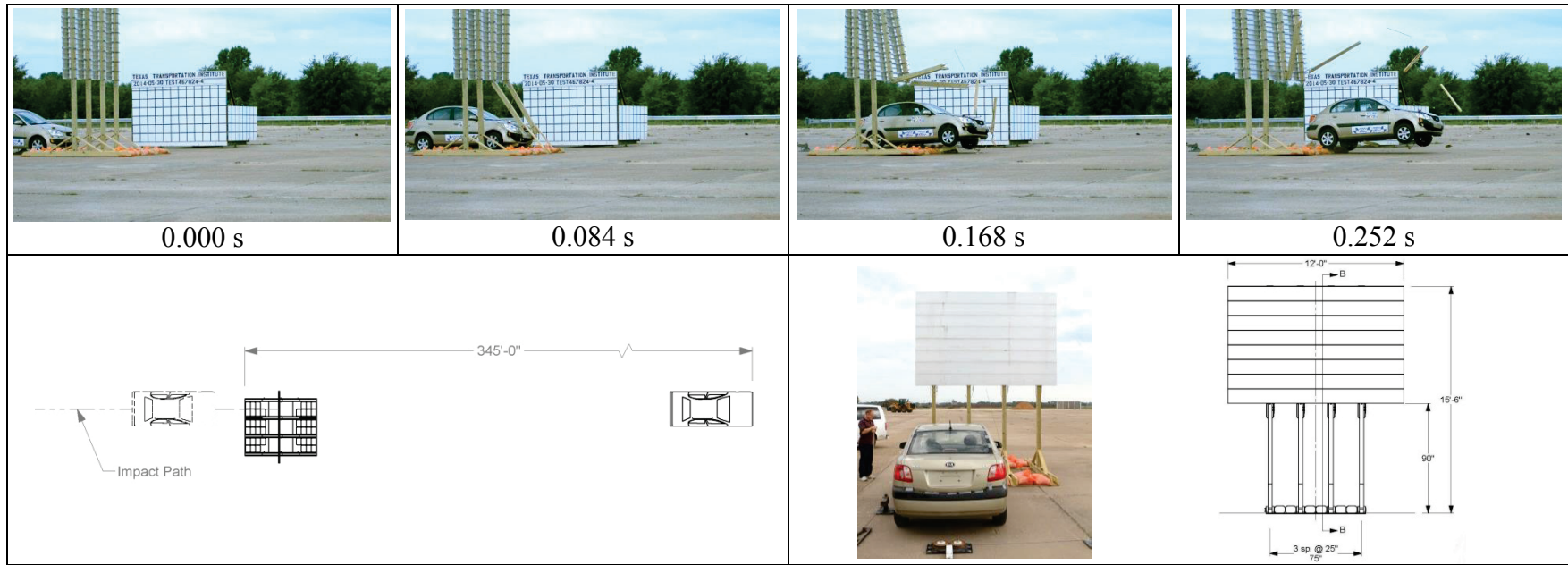

**General Information**

Test Agency ..... Texas A&M Transportation Institute (TTI)  
 Test Standard Test No. .... MASH Test 3-71  
 TTI Test No. .... 467824-4  
 Test Date ..... 2014-5-30

**Test Article**

Type ..... Sign Support  
 Name ..... Skid-Mounted Wood Post Temporary Guide Sign  
 Installation Mounting Height .... 7.5 ft  
 Material or Key Elements ..... 8 ft x 12 ft extruded aluminum panel, four 4-inch x 6-inch wood supports on 2-inch x 6 inch skids, 7.5-ft mounting height

**Soil Type**

Concrete surface

**Test Vehicle**

Type/Designation ..... 1100C  
 Make and Model ..... 2008 Kia Rio  
 Curb .....  
 Test Inertial ..... 2440 lb  
 Dummy ..... 165 lb  
 Gross Static ..... 2605 lb

**Impact Conditions**

Speed ..... 63.1 mph  
 Angle ..... 0 degrees  
 Location/Orientation ..... Head-on centered btw post 1 and 2

**Exit Conditions**

Speed ..... 56.6 mph  
 Angle ..... N.A.

**Occupant Risk Values**

Impact Velocity  
 Longitudinal ..... 7.9 ft/s  
 Lateral ..... 0.0 ft/s  
 Ridedown Accelerations  
 Longitudinal ..... 0.6 G  
 Lateral ..... 1.0 G  
 THIV ..... 2.4 m/s  
 PHD ..... 1.0 G  
 ASI ..... 0.33  
 Max. 0.050-s Average  
 Longitudinal ..... -3.7 G  
 Lateral ..... 0.8 G  
 Vertical ..... -3.0 G

**Post-Impact Trajectory**

Stopping Distance ..... 345 ft

**Vehicle Stability**

Maximum Yaw Angle ..... 4 degrees  
 Maximum Pitch Angle ..... 7 degrees  
 Maximum Roll Angle ..... 8 degrees  
 Vehicle Snagging ..... No  
 Vehicle Pocketing ..... No

**Test Article Debris Pattern**

Longitudinal ..... 165 ft  
 Lateral ..... 2 ft

**Vehicle Damage**

VDS ..... 12FD1  
 CDC ..... 12FLEW1  
 Max. Exterior Deformation ..... None  
 OCDI ..... FS000000  
 Max. Occupant Compartment Deformation ..... None

**Figure 4.15. Summary of Results for MASH Test 3-71 on the Modified Skid-Mounted Support System for Temporary Guide Signs.**

#### 4.6.8.2 Occupant Risk

D. *Detached elements, fragments, or other debris from the test article should not penetrate or show potential for penetrating the occupant compartment, or present an undue hazard to other traffic, pedestrians, or personnel in a work zone.*

*Deformation of, or intrusions into, the occupant compartment should not exceed limits set forth in Section 5.3 and Appendix E of MASH (roof  $\leq 4.0$  inches; windshield =  $\leq 3.0$  inches; side windows = no shattering by test article structural member; wheel/foot well/toe pan  $\leq 9.0$  inches; forward of A-pillar  $\leq 12.0$  inches; front side door area above seat  $\leq 9.0$  inches; front side door below seat  $\leq 12.0$  inches; floor pan/transmission tunnel area  $\leq 12.0$  inches).*

Results: The sign panel, skids, and fractured sections of support posts remained together near the impact point. (PASS)  
No occupant compartment deformation occurred. (PASS)

F. *The vehicle should remain upright during and after collision. The maximum roll and pitch angles are not to exceed 75 degrees.*

Results: The 1100C vehicle remained upright during and after the collision event. Maximum roll and pitch angles were 8 degrees and 7 degrees, respectively. (PASS)

H. *Occupant impact velocities should satisfy the following:*

<i>Longitudinal and Lateral Occupant Impact Velocity</i>	
<u>Preferred</u>	<u>Maximum</u>
<i>10 ft/s</i>	<i>16.4 ft/s</i>

Results: Longitudinal occupant impact velocity was 7.9 ft/s, and there was no lateral occupant impact. (PASS)

I. *Occupant ridedown accelerations should satisfy the following:*

<u>Longitudinal and Lateral Occupant Ridedown Accelerations</u>	
<u>Preferred</u>	<u>Maximum</u>
<i>15.0 Gs</i>	<i>20.49 Gs</i>

Results: Maximum longitudinal ridedown acceleration was 0.6 G. (PASS)

#### 4.6.8.3 Vehicle Trajectory

N. *Vehicle trajectory behind the test article is acceptable.*

Result: The 1100C vehicle came to rest 345 ft behind the installation. (PASS)



## 4.7 MASH TEST 3-72 ON THE MODIFIED SKID-MOUNTED SUPPORT SYSTEM FOR TEMPORARY GUIDE SIGNS (TEST NO. 467824-3)

### 4.7.1 Test Designation and Actual Impact Conditions

MASH Test 3-72 involves a 2270P vehicle weighing 5000 lb  $\pm$  110 lb impacting the sign support at a speed of 62 mph  $\pm$  2.5 mph and a CIA of 0 degrees  $\pm$  1.5 degrees. The target impact point was the centerline of the vehicle aligned with the centerline of support post 2. The 2008 Dodge Ram 1500 pickup used in the test had a test inertial weight of 5016 lb, and the actual impact speed and angle were 63.9 mph and 0 degrees, respectively. The actual impact point was the centerline of the vehicle aligned with the centerline of support post 2 on the left side of the sign support system.

### 4.7.2 Test Vehicle

Figure 4.16 shows a 2008 Dodge Ram 1500 pickup truck was used for the crash test. The test inertia weight of the vehicle was 5016 lb, and the gross static weight was 5016 lb. The height to the lower edge of the vehicle bumper was 16.0 inches, and the height to the upper edge of the bumper was 27.75 inches. Tables H1 and H2 in Appendix H gives additional dimensions and information on the vehicle. The vehicle was directed into the installation using a cable reverse tow and guidance system, and was released to be freewheeling and unrestrained just prior to impact.



Figure 4.16. Vehicle before Test No. 467824-3.

### 4.7.3 Weather Conditions

The test was performed on the afternoon of May 30, 2014. Weather conditions at the time of testing were as follows: wind speed: 8 mph; wind direction: 300 degrees with respect to the vehicle (vehicle was traveling in a northerly direction); temperature: 87°F; and relative humidity: 62 percent.

### 4.7.4 Test Description

The 2008 Dodge Ram 1500 pickup truck, traveling at an impact speed of 63.9 mph, impacted the skid-mounted sign support at an impact angle of 0 degrees with the centerline of the

vehicle aligned with the centerline of support post 2. As it began to traverse the system, the pickup truck plowed through the sand bag ballast that was placed between the horizontal skids. This caused a slight upward pitch as the truck contacted the three 4-inch × 6-inch support posts at approximately 0.049 s. Support posts 1 and 2 fractured near the diagonal braces at 0.055 s, and support post 3 fractured near the diagonal braces at 0.057. Support post 1 fractured below the sign panel at 0.061 s. At 0.063 s, support post 2 fractured below the sign panel, followed by support post 3 at 0.064 s. Support post 4 began to fracture at the upper hinge point at 0.125 s, and the brace on the rear of support post 4 fractured at 0.172 s. The fractured supports rotated upward behind the sign about their restraining cables, and the pickup truck passed underneath the sign panel without any secondary contact to the windshield or roof. At 0.310 s, the vehicle lost contact with the system while traveling at a speed of 58.8 mph. The inertia of the fractured rotating supports rotating into the back of the sign panel caused the remaining support posts to fracture, and the sign panel fell to the ground and came to rest on the skids. Brakes on the vehicle were applied 2.45 s after impact, and the vehicle came to rest 357 ft behind the impact location. Figures H1 and H2 in Appendix H show sequential photographs of the test period.

#### **4.7.5 Damage to Test Installation**

Figure 4.17 shows damage to the skid-mounted sign support system after the test. The impacted support posts fractured at bumper height and below the sign panel as designed. The skids slid 18 inches forward, and the sign panel and support posts came to rest on top of the skids. The braces from support posts 2 and 3 traveled along with the vehicle and came to rest 225 ft downstream and 52 ft to the right of impact. The vehicle came to rest 357 ft downstream of the impact point.

#### **4.7.6 Vehicle Damage**

Figure 4.18 shows the damage that the vehicle sustained during the test, which included the front bumper, hood, and grill. Additionally, the left front tire was deflated. Maximum exterior crush was 3.0 inches in the front plane on the right corner at bumper height. No occupant compartment deformation was noted. Tables H3 and H4 of Appendix H provide exterior crush and occupant compartment measurements.

#### **4.7.7 Occupant Risk Factors**

Data from the accelerometer located at the vehicle center of gravity were digitized for evaluation of occupant risk. In the longitudinal direction, the occupant impact velocity was 6.2 ft/s at 0.385 s, the highest 0.010-s occupant ridedown acceleration was 0.7 Gs from 0.865 to 0.875 s, and the maximum 0.050-s average acceleration was -3.0 Gs between 0.021 and 0.071 s. In the lateral direction, no occupant impact occurred, the highest 0.010-s occupant ridedown acceleration was 1.8 Gs from 0.812 to 0.822 s, and the maximum 0.050-s average was -1.6 Gs between 0.150 and 0.200 s. THIV was 6.9 km/h or 1.9 m/s at 0.385 s; PHD was 1.8 Gs between 0.812 and 0.822 s; and ASI was 0.32 between 0.203 and 0.253 s. Figure 4.19 summarizes these data and other pertinent information from the test. Figures H3 through H9 in Appendix H present the vehicle angular displacements and accelerations versus time traces.

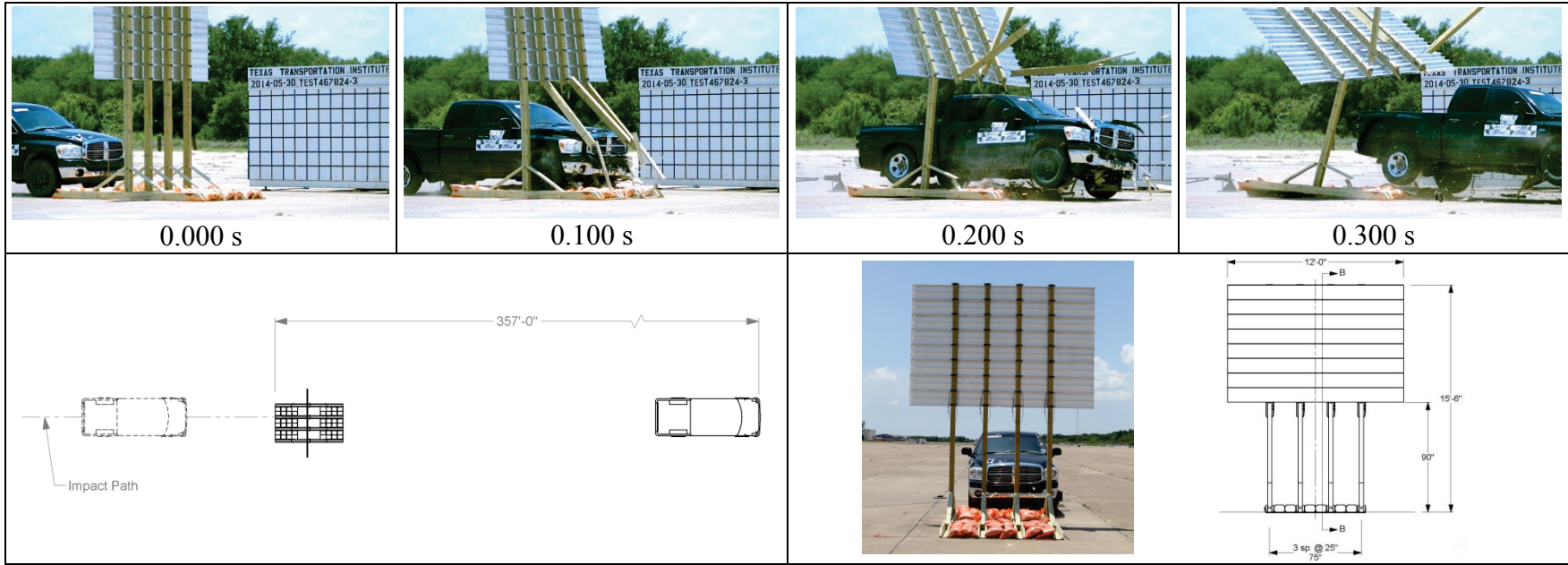

**Figure 4.17. Modified Skid-Mounted Support System for Temporary Guide Signs after Test No. 467824-3.**



**Figure 4.18. Vehicle after Test No. 467824-3.**





**General Information**

Test Agency ..... Texas A&M Transportation Institute (TTI)  
 Test Standard Test No. .... MASH Test 3-72  
 TTI Test No. .... 467824-3  
 Test Date ..... 2014-5-30

**Test Article**

Type ..... Sign Support  
 Name ..... Skid-Mounted Wood Post Temporary Guide Sign  
 Installation Mounting Height .... 7.5 ft  
 Material or Key Elements ..... 8-ft x 12-ft extruded aluminum panel, four 4-inch x 6-inch wood supports on 2-inch x 6-inch skids, 7.5-ft mounting height

**Soil Type**

Concrete surface

**Test Vehicle**

Type/Designation ..... 2270P  
 Make and Model ..... 2008 Dodge Ram 1500 Pickup  
 Curb ..... 4926 lb  
 Test Inertial ..... 5016 lb  
 Dummy ..... No dummy  
 Gross Static ..... 5016 lb

**Impact Conditions**

Speed ..... 63.9 mph  
 Angle ..... 0 degrees  
 Location/Orientation ..... Head-on at post 2

**Exit Conditions**

Speed ..... 58.8 mph  
 Angle ..... N.A.

**Occupant Risk Values**

Impact Velocity  
 Longitudinal ..... 6.2 ft/s  
 Lateral ..... 0.7 ft/s  
 Ridedown Accelerations  
 Longitudinal ..... 0.7 G  
 Lateral ..... 1.8 G  
 THIV ..... 1.9 m/s  
 PHD ..... 1.8 G  
 ASI ..... 0.32

**Max. 0.050-s Average**

Longitudinal ..... -3.0 G  
 Lateral ..... -1.6 G  
 Vertical ..... -3.5 G

**Post-Impact Trajectory**

Stopping Distance ..... 357 ft

**Vehicle Stability**

Maximum Yaw Angle ..... 5 degrees  
 Maximum Pitch Angle ..... 3 degrees  
 Maximum Roll Angle ..... 9 degrees  
 Vehicle Snagging ..... No  
 Vehicle Pocketing ..... No

**Test Article Debris Pattern**

Longitudinal ..... 225 ft  
 Lateral ..... 52 ft

**Vehicle Damage**

VDS ..... 12FD2  
 CDC ..... 12FLEW2  
 Max. Exterior Deformation ..... 3.0 inches  
 OCDI ..... FS000000  
 Max. Occupant Compartment Deformation ..... None

**Figure 4.19. Summary of Results for MASH Test 3-72 on the Modified Skid-Mounted Support System for Temporary Guide Signs.**

#### 4.7.8 Assessment of Test Results

An assessment of the test based on the applicable *MASH* safety evaluation criteria is provided below.

##### 4.7.8.1 Structural Adequacy

- B. *The test article should readily activate in a predictable manner by breaking away, fracturing, or yielding.*

Results: The support posts in the skid-mounted support system for temporary guide signs fractured at bumper height and below the sign panel as designed. (PASS)

##### 4.7.8.2 Occupant Risk

- D. *Detached elements, fragments, or other debris from the test article should not penetrate or show potential for penetrating the occupant compartment, or present an undue hazard to other traffic, pedestrians, or personnel in a work zone.*

*Deformation of, or intrusions into, the occupant compartment should not exceed limits set forth in Section 5.3 and Appendix E of MASH (roof  $\leq 4.0$  inches; windshield =  $\leq 3.0$  inches; side windows = no shattering by test article structural member; wheel/foot well/toe pan  $\leq 9.0$  inches; forward of A-pillar  $\leq 12.0$  inches; front side door area above seat  $\leq 9.0$  inches; front side door below seat  $\leq 12.0$  inches; floor pan/transmission tunnel area  $\leq 12.0$  inches).*

Results: The sign panel, skids, and fractured sections of support posts remained together near the impact point. (PASS)  
No occupant compartment deformation occurred. (PASS)

- F. *The vehicle should remain upright during and after collision. The maximum roll and pitch angles are not to exceed 75 degrees.*

Results: The 2270P vehicle remained upright during and after the collision event. Maximum roll and pitch angles were 9 degrees and 3 degrees, respectively. (PASS)

- H. *Occupant impact velocities should satisfy the following:*

<u>Preferred</u>	<u>Maximum</u>
10 ft/s	16.4 ft/s

Results: Longitudinal occupant impact velocity was 6.2 ft/s, and lateral occupant impact velocity was 0.7 ft/s. (PASS)

- I. *Occupant ridedown accelerations should satisfy the following:*

<u>Longitudinal and Lateral Occupant Ridedown Accelerations</u>	
<u>Preferred</u>	<u>Maximum</u>
15.0 Gs	20.49 Gs

Results: Maximum longitudinal ridedown acceleration was 0.7 G, and maximum lateral ridedown acceleration was 1.8 G. (PASS)

#### 4.7.8.3 Vehicle Trajectory

*N. Vehicle trajectory behind the test article is acceptable.*

Result: The 2270P vehicle came to rest 357 ft behind the installation. (PASS)

## 4.8 CONCLUSIONS

The modified freestanding, skid-mounted support system for large guide signs successfully meets *MASH* impact performance criteria. The full-scale crash tests establish an upper limit on post strength. The results of the crash tests can be used to establish acceptance of other less critical design configurations. For example, various 4-inch × 4-inch posts would be acceptable, provided the combined flexural strength of the supports spaced within the width of the vehicle is less than or equal to the combined strength of the 4-inch × 6-inch posts that were impacted in the testing. Chapter 5 presents a set of guidelines and standards for direct freestanding, skid-mounted guide signs that were developed.

## CHAPTER 5. GUIDELINES FOR TEMPORARY SUPPORT SYSTEMS FOR GUIDE SIGNS<sup>†</sup>

In the first year of this project, two different direct embedded sign support systems were developed and successfully crash-tested for use in temporary applications (4). The first utilized direct embedded wood supports with weakening holes at the ground line and below the sign panel, and the second used direct embedded steel foundation posts with standard slip base and fuse plate mechanisms.

As reported here, in the second year of the project, the researchers designed and successfully crash-tested a freestanding, skid-mounted support system for large guide. The wooden support posts have weakening holes at the ground line and below the sign panel. The supports are attached to wooden skids, and a ballast is placed across the skids to resist wind loads.

Wind load charts were developed for the successfully tested wood support systems: both the direct embedded and skid-mounted systems. The steel supports and slip base details used in the direct embedded steel support system are the same as those used for installation of permanent roadside guide signs. Therefore, this system uses existing wind load charts found on SMD(8W1)-08, “Large Roadside Sign Supports Post Selection Worksheet.”

The wind load charts include information required to appropriately select the number and size of supports for a given size sign. The legacy method of wind load analysis presented in Appendix C of the AASHTO *Standard Specifications for Structural Supports for Highway Signs, Luminaires, and Traffic Signals* was used to be consistent with other wind load charts that TxDOT currently use, including those contained on SMD(8W1)-08 for design of permanent large guide sign installations.

In addition, the researchers developed the recommended embedment depths for both the direct embedded wood and steel support systems. Ballast requirements were established to prevent overturning of the skid-mounted system during a design wind event.

### 5.1 DIRECT EMBEDDED WOOD SUPPORT SYSTEM

The design wind pressure is based on the basic wind speed and the anticipated design life of the structure. As shown on the WV&IZ-96 “Wind Velocity and Ice Zone Worksheet,” design wind speeds of 70 mph and 80 mph cover almost the entire state of Texas with the exception of some higher wind zones on the extreme coast and the extreme tip of the panhandle. These design wind speeds are based on a 25-year mean recurrence interval. The AASHTO *Standard Specifications for Structural Supports for Highway Signs, Luminaires and Traffic Signals* recommends a 10-year mean recurrence interval for roadside sign structures (1). For a 10-year mean recurrence interval, the design wind speeds that cover the state of Texas drop to 60 mph and 70 mph, respectively.

Given that the direct embedded wood post system is intended for temporary applications, the researchers concluded that a 10-year mean recurrence interval would be more than satisfactory for

---

<sup>†</sup> The interpretations expressed in this section of the report are outside the scope of TTI’s A2LA Accreditation.

this design application. Therefore, design charts for the direct embedded wood post system were developed using the legacy method for two design wind speeds: 60 mph and 70 mph.

The support sizes incorporated into the design charts include 4-inch  $\times$  4-inch, 4-inch  $\times$  6-inch, and 6-inch  $\times$  8-inch. Note that any of these posts can be purchased rough sawn or surfaced on four sides (S4S). A rough sawn post will have actual cross sectional dimensions corresponding to the nominal dimensions of the post. For example, a rough sawn 6-inch  $\times$  8-inch post will be 6 inches wide and 8 inches deep. The actual dimensions of an S4S post will be slightly less than the nominal dimensions of the post due to the planing operation that makes the post surfaces more smooth and uniform. For example, an S4S 4-inch  $\times$  4-inch post will have actual dimensions of 3½-inches  $\times$  3½-inches.

The 4-inch  $\times$  4-inch and 4-inch  $\times$  6-inch posts available at many local lumber yards and home improvement stores are commonly S4S. However, they can be ordered as rough sawn posts. The larger 6-inch  $\times$  8-inch post size is not readily available at local home improvement stores, but can be ordered. When ordering wood supports for use in the direct embedded sign support system, it is logical to order rough sawn posts. The rough sawn posts will likely be less expensive due to elimination of the planing process, and the larger cross section has more capacity than a similarly sized S4S post. Consequently, a design chart for the direct embedded wood support system has been developed for rough sawn posts for each of the two selected design wind speeds.

However, some contractors may find it convenient to purchase immediately available material from their local home improvement store or lumber yard. Since this material is typically S4S, a set of design charts has also been developed for S4S posts. Note that in both charts, the 6-inch  $\times$  8-inch posts are assumed to be rough sawn since this size is not as readily available at local home improvement stores and would likely be ordered rough sawn as needed.

Figure 5.1 and Figure 5.2 present the post selection charts for a 60-mph design wind speed for rough sawn and S4S lumber, respectively. The x-axis of the charts is sign panel width and the y-axis of the charts is sign panel height. Note that different height axes are available for use depending on the mounting height of the sign with respect to the local terrain. Different axes are available for sign mounting heights of 7, 10, 13, and 16 ft. The nominal mounting height of a large guide sign is 7 ft with respect to the roadway surface. Because roadside terrain typically includes slopes and ditches to provide required hydraulic capacity, the actual mounting height from the local ground to the bottom of the sign panel is often greater than the nominal mounting height. This actual mounting height dictates the required moment capacity of the support post.

The sign dimensions used to develop the charts correspond to those used on SMD(8W1)-08, “Large Roadside Sign Supports Post Selection Worksheet.” The grey area at the top of each chart represents sign panel sizes that the direct embedded wood post system cannot currently accommodate. The full-scale crash testing that was successfully performed on the system establishes the permissible size and spacing of the support posts. While the crash test results indicate that the direct embedded sign support system can be extended for use with larger signs than currently permitted, further crash testing is required to verify the crashworthiness of the larger support posts.



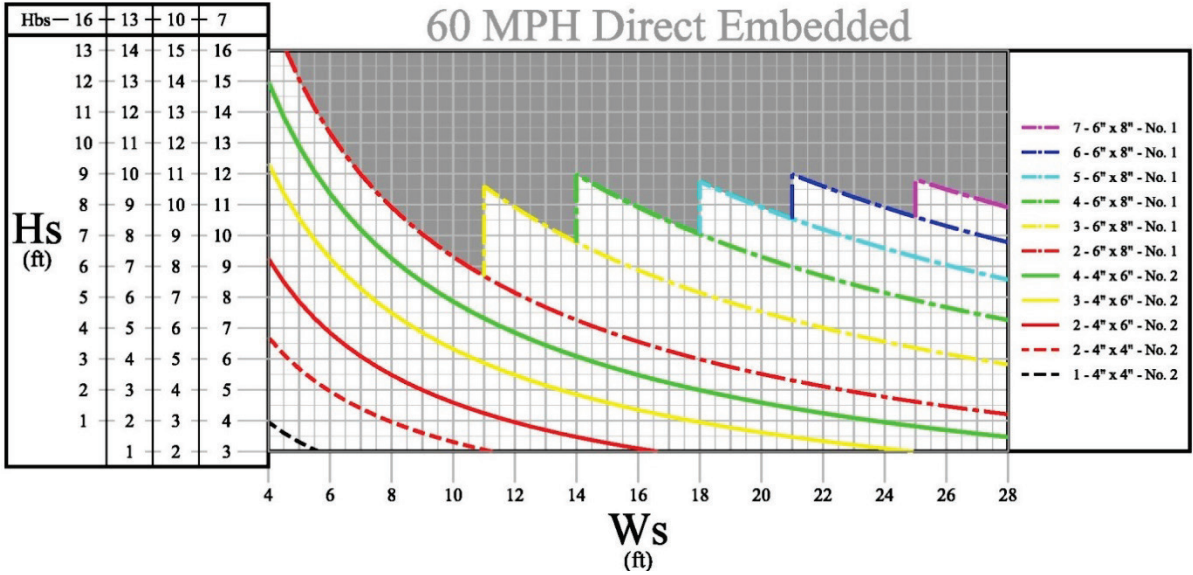

Figure 5.1. Design Chart for Direct Embedded Wood Support System with Rough Sawn Posts (60 mph Design Wind Speed).

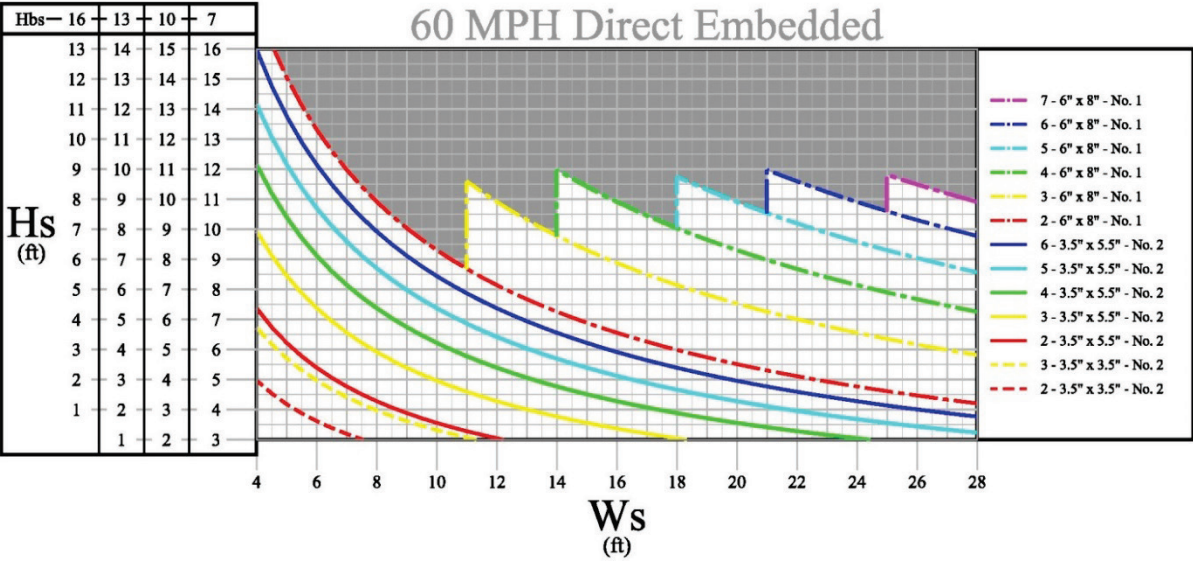
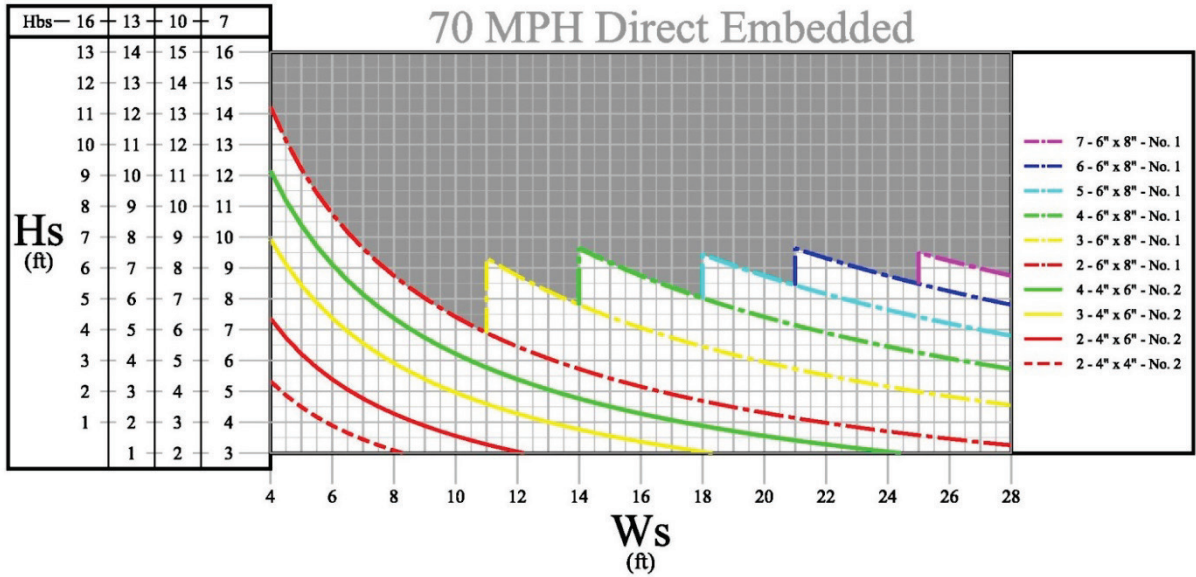
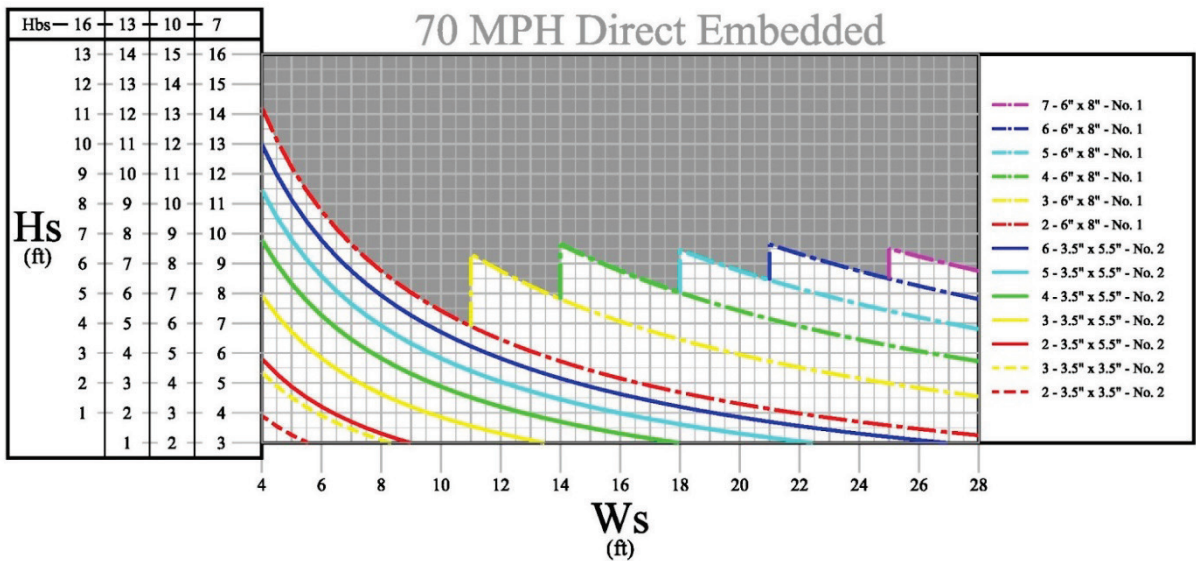

Figure 5.2. Design Chart for Direct Embedded Wood Support System with S4S Posts (60 mph Design Wind Speed).

Figure 5.3 and Figure 5.4 present similar design charts for a 70-mph design wind speed for rough sawn and S4S posts, respectively. The following example illustrates the use of the design charts.



**Figure 5.3. Design Chart for Direct Embedded Wood Support System Rough Sawn Posts (70 mph Design Wind Speed).**



**Figure 5.4. Design Chart for Direct Embedded Wood Support System with S4S Posts (70 mph Design Wind Speed).**

**Example:** Select the appropriate number and size of supports for a direct embedded wood support system for an 8-ft tall  $\times$  12-ft wide sign panel. The mounting height is 7 ft (i.e., flat roadside), and the sign will be installed in a 70-mph design wind velocity zone.

**Solution:** With reference to Figure 5.3, find the intersection point for a sign that is 8-ft tall (using 7-ft mounting height axis) and 12-ft wide. Determine the curve that is above the projected point. With reference to the legend, it can be seen that three 6-inch  $\times$  8-inch posts are required to support the sign.

The number of design charts can be reduced if a decision regarding post surfacing is made. For example, Figure 5.2 could be used as the single chart for a 60-mph wind speed zone. The 6-inch × 8-inch posts would be required to be rough sawn, which is logical given that they will typically be ordered from a lumber yard for use in this application. The other two smaller posts would be specified as S4S, which is what is commonly found in most local lumber yards and home improvement stores. Specifying an S4S post would be conservative and would not preclude the use of a rough sawn post. However, it would not take advantage of the additional strength of a rough sawn post if one were used.

The AASHTO *Standard Specifications for Structural Supports for Highway Signs, Luminaires, and Traffic Signals (1)* suggests using Brom’s method for designing foundations for sign support structures. This method has two complimentary models for analyzing foundation requirements. One model is for the design of foundations in cohesionless soils such as sand, and the other is intended to be used for cohesive soils such as clay.

Table 5.1 presents the results of an analysis of the required embedment depth for direct embedded wood support posts. A cohesive soil with a “c” value of 3100 psf was assumed in the analysis. It can be seen that the required embedment depth for a 4-inch × 8-inch post is 4.0 ft. The embedment depth for a 4-inch × 4-inch post is only 2.5 ft. If the supports are to be placed in non-cohesive soils, it is recommended that the foundation embedment depth be reanalyzed using Brom’s method for cohesionless soils. If soils are known to be stronger than the values used here, the analysis can be repeated using actual soil values to take advantage of the stronger soil conditions to reduce the required embedment depth.

**Table 5.1. Recommended Embedment Depths for Direct Embedded Wood Support Posts.**

<b>Timber Post Size</b>	<b>Embedment Depth (ft)</b>
4 × 4	2.5
4 × 6	3.0
6 × 8	4.0

## **5.2 DIRECT EMBEDDED STEEL SUPPORT SYSTEM**

The direct embed steel foundation post assemblies were designed and detailed for use with temporary guide signs with steel support posts. The direct embedment installation method allows for currently installed large guide signs to be relocated temporarily on driven steel foundation posts without installing expensive and hard to remove concrete foundations. The steel supports and slip base details used in the direct embedded steel support system are the same as those used for installing permanent roadside guide signs. Therefore, the proper selection of steel support posts for a given size sign panel is made using existing wind load charts found on SMD(8W1)-08, “Large Roadside Sign Supports Post Selection Worksheet.”

The size of the direct embedded steel foundation post should be selected to match the size of the support posts used in the sign support system. The foundations posts include a standard slip base assembly above ground that mates with matching slip base plates on the steel support posts.

Details of the slip base, fuse plate, and sign panel connections are found in SMD(2-1)-08 through SMD(2-3)-08, which are sign-mounting details for large roadside signs.

Table 5.2 presents the results of an analysis using Brom’s method to determine the required embedment depth for direct embedded steel foundation posts. A cohesive soil with a “c” value of 3100 psf was assumed in the analysis. As an example, the recommended embedment depth for a W6×15 steel foundation post is 5.0 ft. The embedment depth for an S3×5.7 post is only 3.0 ft.

**Table 5.2. Recommended Embedment Depths for Direct Embedded Steel Foundation Posts.**

<b>Steel Support Size</b>	<b>Embedment Depth (ft)</b>
W6×9	4.0
W6×12	4.5
W6×15	5.0
W8×18	6.0
W8×21	6.5
W10×22	7.5
W10×26	8.0
W12×26	8.5
S3×5.7	3.0
S4×7.7	3.5

### **5.3 FREESTANDING, SKID-MOUNTED SIGN SUPPORT SYSTEM**

As with the direct embedded wood sign support system, the development of the freestanding, skid-mounted sign support system included consideration of factors such as support post size, length, and grade. Availability and cost were also important design considerations.

The design approach used for the skid-mounted sign support system was to use multiple, small wood supports that can independently fracture during impact, rather than fewer larger supports. The support posts had to be practically and economically supported by and attached to skids running perpendicular to the sign panel.

Because of a desire to fabricate the skid-mounted sign support system from readily available materials, Grade 2 SYP was selected for the design. This grade material is readily available in the selected sizes from any local lumber yard or home improvement store, making it easily accessible to contractors and maintenance personnel.

Compared to the direct embedded system, the skid-mounted design has the advantage of being more portable and can be easily removed or relocated on the job site. However, because it does not have a ground-mounted foundation, this design needs a proper ballast to prevent overturn of the skid-mounted system during wind events. The researchers performed an overturning analysis to determine the amount of ballast (in the form of 40-lb sand bags) required for the skid-mounted temporary sign support system for different wind speeds. It was determined that the amount of



ballast required to accommodate a 60 mph design wind speed was impractical to achieve in the field and offset the benefit associated with a portable, skid-mounted sign support system.

A rational approach for reducing the ballast requirements to more practical levels was to select a design wind speed based on a reasonable duration for the work zone construction projects for which the use of the skid-mounted temporary guide signs is anticipated. A mean recurrence interval of 2 years was selected in consultation with the PMC based on the expected duration of construction projects for which the application of a skid-mounted guide sign might be useful. The design wind speed corresponding to a 2-year recurrence interval was determined to be 48 mph. This design wind speed was used for developing design charts for the skid-mounted temporary guide signs.

Figure 5.5 presents the post selection chart for a 48-mph design wind speed. The x-axis of the chart corresponds to sign panel width and the y-axis of the chart corresponds to sign panel height. Note that unlike the direct embedded wood sign support system, only one height axis is required. This is because the skid-mounted system is constructed with a specific mounting height of 7½ ft, and is assumed to be placed on terrain that is relatively flat.

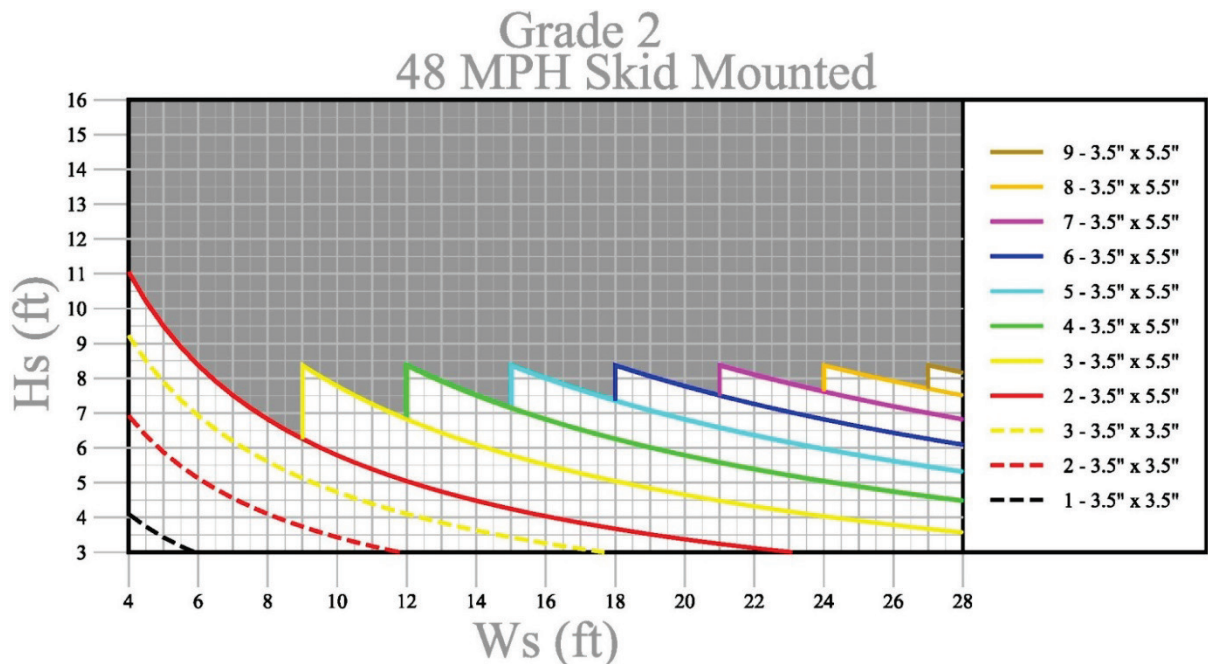

**Figure 5.5. Design Chart for Post Selection for Skid-Mounted Sign Support System.**

The following example illustrates the use of the design chart.

**Example:** Select the appropriate number and size of wood supports for a free standing, skid-mounted sign support system intended to support an 8-ft tall × 12-ft wide sign panel.

**Solution:** With reference to Figure 5.5, find the intersection point for a sign that is 8-ft tall and 12-ft wide. Determine the curve that is above the projected point. With reference to the legend, it can be seen that four, Grade 2, 4-inch × 6-inch (actual dimensions are 3½-inch × 5½-inch for S4S) posts are required to support the sign.

Figure 5.6 presents the ballast selection chart for the skid-mounted temporary guide signs. This chart indicates the total number of 40-lb sand bags required for a specified sign area. Note that the number of sand bags indicated in the chart is the total amount required, and this amount would be equally divided on each side of the skids. With reference to Figure 5.6, it can be seen that 45 sand bags are required for the 8-ft tall  $\times$  12-ft wide sign panel used in the above example.

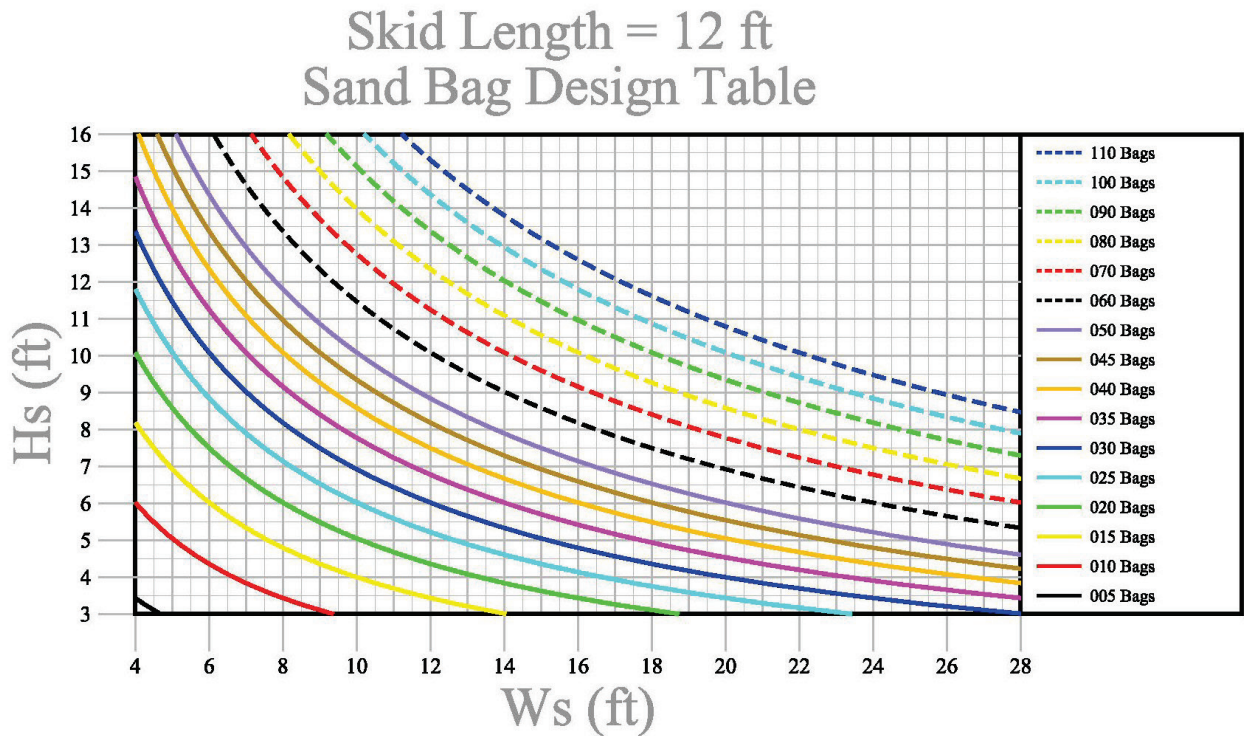

**Figure 5.6. Design Chart for Ballast Required for Skid-Mounted Sign Support System.**

#### 5.4 SUMMARY

Design charts have been developed to assist with the implementation of the direct embedded wood and steel sign support systems, and the freestanding, skid-mounted sign support system that were successfully developed under this project. The charts permit the proper selection of the size and number of posts required to support a specified sign panel. Recommended embedment depths are provided for the direct embedded systems. Additionally, a chart is provided to permit the proper determination of ballast (sand bags) for the skid-mounted sign support system.

## CHAPTER 6. SUMMARY AND CONCLUSIONS

### 6.1 SKID-MOUNTED SUPPORT SYSTEM FOR TEMPORARY GUIDE SIGNS

A skid-mounted support system for temporary guide signs was developed and crash tested in accordance with *MASH* guidelines. In Test 3-70, the skid-mounted system was pushed forward by the vehicle and then came to rest in contact with the system. Although the support posts did not fracture, all occupant risk criteria were within *MASH* requirements for breakaway support structures. The occupant impact velocity, which is the primary concern for this test, was 12.1 ft/sec. This is less than the acceptable threshold of 16 ft/sec. The occupant compartment of the test vehicle was undeformed. As summarized in Table 6.1, the skid-mounted support system for temporary guide signs met all applicable *MASH* evaluation criteria for Test 3-60.

With the success of Test 3-70, Test 3-71 was performed to further evaluate the impact performance of the skid-mounted support system. Upon impact, the plywood platform imparted a significant impulse to the small car, driving the front wheels rearward and decelerating the car. The car subsequently climbed on top of the plywood platform, plowed through some sand bags, and impacted three support posts. The support posts did not fracture as intended, and the entire support system was pushed forward approximately 75 ft before coming to rest near the vehicle. Although the vehicle damage was acceptable, the occupant impact velocity was too high (30.8 ft/s compared to an allowable of 16 ft/s). Consequently, as indicated in Table 6.2, the skid-mounted support system failed to meet *MASH* impact performance requirements for Test 3-71.

TTI research engineers modified the design of the skid-mounted support system for temporary guide signs to address the identified problems. Changes included:

- Moving the plywood platform to the bottom of the skids to reduce the impulse on the impacting vehicle.
- Incorporating weakening holes in the support posts near bumper height to reduce their fracture strength.
- Modifying the bracing of the support posts to permit better release of the fractured supports.

Crash testing was performed to evaluate the impact performance of the modified design. It was concluded that the low-speed car test (Test 3-70) did not need to be rerun because the vehicle decelerations for the modified system would be equal or less than (if one or more supports fractured) that observed in the test. Therefore, the test matrix for the modified design consisted of two tests: test 3-71 (high-speed small car test) and test 3-72 (high-speed pickup truck test).

Test 3-71 was repeated on the modified skid-mounted support system for temporary guide signs. As it began to traverse the system, the car plowed through the sand bag ballast that was placed between the horizontal skids. This caused a slight upward pitch as it contacted the two 4-inch × 6-inch support posts. The support posts fractured at bumper height and below the sign panel as designed. The fractured supports rotated upward behind the sign about their restraining cables, and the vehicle passed underneath the sign panel and exited the sign system

without any secondary contact to the windshield or roof. The sign support system remained in place and upright, with the remaining posts holding up the extruded aluminum sign panel. The vehicle sustained only minor damage. The Occupant Impact Velocity (OIV), which was the cause of failure in the previous small car high-speed test, was only 7.9 ft/s, which is below the preferred value in *MASH*. As Table 6.3 summarizes, the modified skid-mounted support system for temporary guide signs met all applicable *MASH* evaluation criteria for Test 3-71.

With the success of Test 3-71, Test 3-72 was performed. As Table 6.4 shows, the modified skid-mounted support system for temporary guide signs met all applicable *MASH* evaluation criteria for Test 3-72. The support posts fractured at bumper height and below the sign panel as designed. The fractured supports rotated upward behind the sign about their restraining cables, and the pickup truck passed underneath the sign panel and exited the sign system without any secondary contact to the windshield or roof. The pickup truck sustained only minor damage. The OIV was 6.2 ft/s, which is below the preferred value in *MASH*.

In conclusion, the modified skid-mounted support system for temporary guide signs met all required *MASH* evaluation criteria. Implementation recommendations regarding the system are discussed in Chapter 8.

## **6.2 GUIDELINES FOR TEMPORARY SIGN SUPPORT SYSTEMS FOR LARGE GUIDE SIGNS**

Wind load design charts were developed for the successfully tested wood support systems, both the direct embedded and skid-mounted systems. These charts permit the proper selection of the size, grade, and number of wood posts required to support a given size sign panel. The size of the direct embedded steel foundation post is selected to match the size of the support posts used in the sign support system as indicated on SMD(8W1)-08, "Large Roadside Sign Supports Post Selection Worksheet."

Recommended embedment depths were developed for both the direct embedded wood and steel support systems. Additionally, ballast requirements were determined for the skid-mounted sign support system to prevent overturning of the skid-mounted system during a design wind event. The design wind speed used for designing the skid-mounted system was based on a mean recurrence interval of 2 years, which was considered a reasonable duration for projects in which the skid-mounted sign support system for guide signs is considered applicable.



**Table 6.1. Performance Evaluation Summary for MASH Test 3-70 on the Skid-Mounted Support System for Temporary Guide Signs.**

Test Agency: Texas A&M Transportation Institute

Test No.: 467824-1

Test Date: 2015-05-15

<b>MASH Test 3-70 Evaluation Criteria</b>	<b>Test Results</b>	<b>Assessment</b>
<p>Structural Adequacy</p> <p><i>B. The test article should readily activate in a predictable manner by breaking away, fracturing, or yielding.</i></p>	The skid-mounted support system for temporary guide signs performed acceptably by sliding along with the vehicle.	Pass
<p>Occupant Risk</p> <p><i>D. Detached elements, fragments, or other debris from the test article should not penetrate or show potential for penetrating the occupant compartment, or present an undue hazard to other traffic, pedestrians, or personnel in a work zone.</i></p>	No detached elements, fragments, or other debris was present to penetrate or show potential for penetrating the occupant compartment, or to present an undue hazard to others.	Pass
<p><i>Deformations of, or intrusions into, the occupant compartment should not exceed limits set forth in Section 5.3 and Appendix E of MASH.</i></p>	No occupant compartment deformation occurred.	Pass
<p><i>F. The vehicle should remain upright during and after collision. The maximum roll and pitch angles are not to exceed 75 degrees.</i></p>	The 1100C vehicle remained upright during and after the collision event. Maximum roll and pitch angles were 8 degrees and 3 degrees, respectively.	Pass
<p><i>H. Longitudinal and lateral occupant impact velocities should fall below the preferred value of 10 ft/s, or at least below the maximum allowable value of 16.4 ft/s.</i></p>	Longitudinal occupant impact velocity was 12.1 ft/s, and lateral occupant impact velocity was 0.3 ft/s.	Pass
<p><i>I. Longitudinal and lateral occupant ridedown accelerations should fall below the preferred value of 15.0 Gs, or at least below the maximum allowable value of 20.49 Gs.</i></p>	Maximum longitudinal ridedown acceleration was 1.1 G, and maximum lateral ridedown acceleration was 1.3 G.	Pass
<p>Vehicle Trajectory</p> <p><i>N. Vehicle trajectory behind the test article is acceptable.</i></p>	The 1100C vehicle came to rest against the installation.	NA

**Table 6.2. Performance Evaluation Summary for MASH Test 3-71 on the Skid-Mounted Support System for Temporary Guide Signs.**

Test Agency: Texas A&M Transportation Institute

Test No.: 467824-2

Test Date: 2014-05-15

<b>MASH Test 3-71 Evaluation Criteria</b>	<b>Test Results</b>	<b>Assessment</b>
Structural Adequacy <i>B. The test article should readily activate in a predictable manner by breaking away, fracturing, or yielding.</i>	Several of the wood support posts fractured below the sign panel and the system slid forward with the vehicle.	Pass
Occupant Risk <i>D. Detached elements, fragments, or other debris from the test article should not penetrate or show potential for penetrating the occupant compartment, or present an undue hazard to other traffic, pedestrians, or personnel in a work zone.</i>	The sign panel and fractured sections of posts fell on the vehicle roof, resulting in 2.0 inches of deformation into the occupant compartment over the rear passenger area.	Pass
<i>Deformations of, or intrusions into, the occupant compartment should not exceed limits set forth in Section 5.3 and Appendix E of MASH.</i>	Maximum occupant compartment deformation was 2.0 inches in the rear passenger roof area.	Pass
<i>F. The vehicle should remain upright during and after collision. The maximum roll and pitch angles are not to exceed 75 degrees.</i>	The 1100C vehicle remained upright during and after the collision event. Maximum roll and pitch angles were 13 degrees and 17 degrees, respectively.	Pass
<i>H. Longitudinal and lateral occupant impact velocities should fall below the preferred value of 10 ft/s, or at least below the maximum allowable value of 16.4 ft/s.</i>	Longitudinal occupant impact velocity was 30.8 ft/s, and lateral occupant impact velocity was 1.0 ft/s.	<b>Fail</b>
<i>I. Longitudinal and lateral occupant ridedown accelerations should fall below the preferred value of 15.0 Gs, or at least below the maximum allowable value of 20.49 Gs.</i>	Maximum longitudinal ridedown acceleration was 4.9 G, and maximum lateral ridedown acceleration was 2.0 G.	Pass
Vehicle Trajectory <i>N. Vehicle trajectory behind the test article is acceptable.</i>	The 1100C vehicle came to rest 75.5 ft behind the installation.	Pass

**Table 6.3. Performance Evaluation Summary for *MASH* Test 3-71 on the Modified Skid-Mounted Support System for Temporary Guide Signs.**

Test Agency: Texas A&M Transportation Institute

Test No.: 467824-4

Test Date: 2014-05-30

<b><i>MASH</i> Test 3-71 Evaluation Criteria</b>	<b>Test Results</b>	<b>Assessment</b>
<b>Structural Adequacy</b> <i>B. The test article should readily activate in a predictable manner by breaking away, fracturing, or yielding.</i>	The skid-mounted support system for temporary guide signs fractured at below the sign panel and at bumper height as designed.	Pass
<b>Occupant Risk</b> <i>D. Detached elements, fragments, or other debris from the test article should not penetrate or show potential for penetrating the occupant compartment, or present an undue hazard to other traffic, pedestrians, or personnel in a work zone.</i>	The sign panel, skids, and fractured sections of support posts remained together near the impact point.	Pass
<i>Deformations of, or intrusions into, the occupant compartment should not exceed limits set forth in Section 5.3 and Appendix E of MASH.</i>	No occupant compartment deformation occurred.	Pass
<i>F. The vehicle should remain upright during and after collision. The maximum roll and pitch angles are not to exceed 75 degrees.</i>	The 1100C vehicle remained upright during and after the collision event. Maximum roll and pitch angles were 8 degrees and 7 degrees, respectively.	Pass
<i>H. Longitudinal and lateral occupant impact velocities should fall below the preferred value of 10 ft/s, or at least below the maximum allowable value of 16.4 ft/s.</i>	Longitudinal occupant impact velocity was 7.9 ft/s, and there was no lateral occupant impact.	Pass
<i>I. Longitudinal and lateral occupant ridedown accelerations should fall below the preferred value of 15.0 Gs, or at least below the maximum allowable value of 20.49 Gs.</i>	Maximum longitudinal ridedown acceleration was 0.6 G.	Pass
<b>Vehicle Trajectory</b> <i>N. Vehicle trajectory behind the test article is acceptable.</i>	The 1100C vehicle came to rest 345 ft behind the installation.	Pass

**Table 6.4. Performance Evaluation Summary for MASH Test 3-72 on the Modified Skid-Mounted Support System for Temporary Guide Signs.**

Test Agency: Texas A&M Transportation Institute

Test No.: 467824-3

Test Date: 2014-05-30

<b>MASH Test 3-72 Evaluation Criteria</b>	<b>Test Results</b>	<b>Assessment</b>
<b>Structural Adequacy</b> <i>B. The test article should readily activate in a predictable manner by breaking away, fracturing, or yielding.</i>	The skid-mounted support system for temporary guide signs fractured at below the sign panel and at bumper height as designed.	Pass
<b>Occupant Risk</b> <i>D. Detached elements, fragments, or other debris from the test article should not penetrate or show potential for penetrating the occupant compartment, or present an undue hazard to other traffic, pedestrians, or personnel in a work zone.</i>	The sign panel, skids, and fractured sections of support posts remained together near the impact point.	Pass
<i>Deformations of, or intrusions into, the occupant compartment should not exceed limits set forth in Section 5.3 and Appendix E of MASH.</i>	No occupant compartment deformation occurred.	Pass
<i>F. The vehicle should remain upright during and after collision. The maximum roll and pitch angles are not to exceed 75 degrees.</i>	The 2270P vehicle remained upright during and after the collision event. Maximum roll and pitch angles were 9 degrees and 3 degrees, respectively.	Pass
<i>H. Longitudinal and lateral occupant impact velocities should fall below the preferred value of 10 ft/s, or at least below the maximum allowable value of 16.4 ft/s.</i>	Longitudinal occupant impact velocity was 6.2 ft/s, and lateral occupant impact velocity was 0.7 ft/s.	Pass
<i>I. Longitudinal and lateral occupant ridedown accelerations should fall below the preferred value of 15.0 Gs, or at least below the maximum allowable value of 20.49 Gs.</i>	Maximum longitudinal ridedown acceleration was 0.7 G, and maximum lateral ridedown acceleration was 1.8 G.	Pass
<b>Vehicle Trajectory</b> <i>N. Vehicle trajectory behind the test article is acceptable.</i>	The 2270P vehicle came to rest 357 ft behind the installation.	Pass

## CHAPTER 7. IMPLEMENTATION STATEMENT\*

### 7.1 SKID-MOUNTED SUPPORT SYSTEM FOR TEMPORARY GUIDE SIGNS

A skid-mounted temporary support system for large guide signs was developed and successfully crash tested in accordance with *MASH* guidelines. This system provides a cost-effective option for phased highway construction projects in which there is a need to readily move and relocate large guide signs for temporary use. Horizontal skids that run perpendicular to the sign panel hold up the wooden support posts. Ballast is applied to the skids to help prevent overturn in the event of strong winds.

The skid-mounted temporary support system for large guide signs met all applicable *MASH* evaluation criteria and is considered suitable for implementation. Implementation can be effectively accomplished through the issuance of a new standard detail sheet through the Traffic Operations Division. Appendix E presents detailed drawings of the tested system that can be used for this purpose.

The results of the crash tests reported here can be used to establish acceptance of other less critical design configurations for other sizes of temporary guide signs. For example, the testing with the stronger 4-inch × 6-inch wood posts provides the basis for accepting smaller 4-inch × 4-inch wood posts. Additionally, testing the more critical extruded aluminum sign substrate provides the basis for using plywood substrates with the skid-mounted temporary support system.

### 7.2 GUIDELINES FOR TEMPORARY SIGN SUPPORT SYSTEMS FOR LARGE GUIDE SIGNS

Engineering analyses were performed to develop design charts for the proper selection of the size, grade, and number of wood support posts for both the direct embedded wood sign support system developed in year one of the project and the skid-mounted support system developed in year two of the project. The charts include various post sizes that permit an economical support selection for a given size sign panel.

Guidance has also developed regarding recommended embedment depth for the direct embedded wood and steel post systems, and recommended ballast for the skid-mounted sign support system.

These guidelines can be implemented through the development of standard detail sheets that provide the design details of each system along with their respective design selection charts.

---

\* The interpretations expressed in this section of the report are outside the scope of TTI's A2LA Accreditation.



## REFERENCES

1. AASHTO, *Standard Specifications for Structural Supports for Highway Signs, Luminaires, and Traffic Signals*, American Association of State Highway and Transportation Officials, Washington, D.C., 2013.
2. AASHTO, *Manual for Assessing Safety Hardware*, American Association of State Highway and Transportation Officials, Washington, D.C., 2009.
3. R. P. Bligh, *Design Wind Load Determination for Work Zone Traffic Control Devices*, Transportation Research Record 1877, Transportation Research Board, Washington, D.C., 2004.
4. R. P. Bligh, D. R. Arrington, and W. L. Menges, *Temporary Large Guide Signs*, Report FHWA/TX-13/0-6782-1, Texas A&M Transportation Institute, College Station, TX, 2013.





Assembly Parts		
#	Part Name	QTY.
1	Panel Assembly	1
2	Frame Assembly	1
3	Cable Assembly	5
4	40lb Sandbag	44
5	Clamp Plate	45
6	Bolt, 3/8 x 6-1/2 square head	90
7	Washer, 3/8 lock	90
8	Nut, 3/8 hex	90

Isometric Views

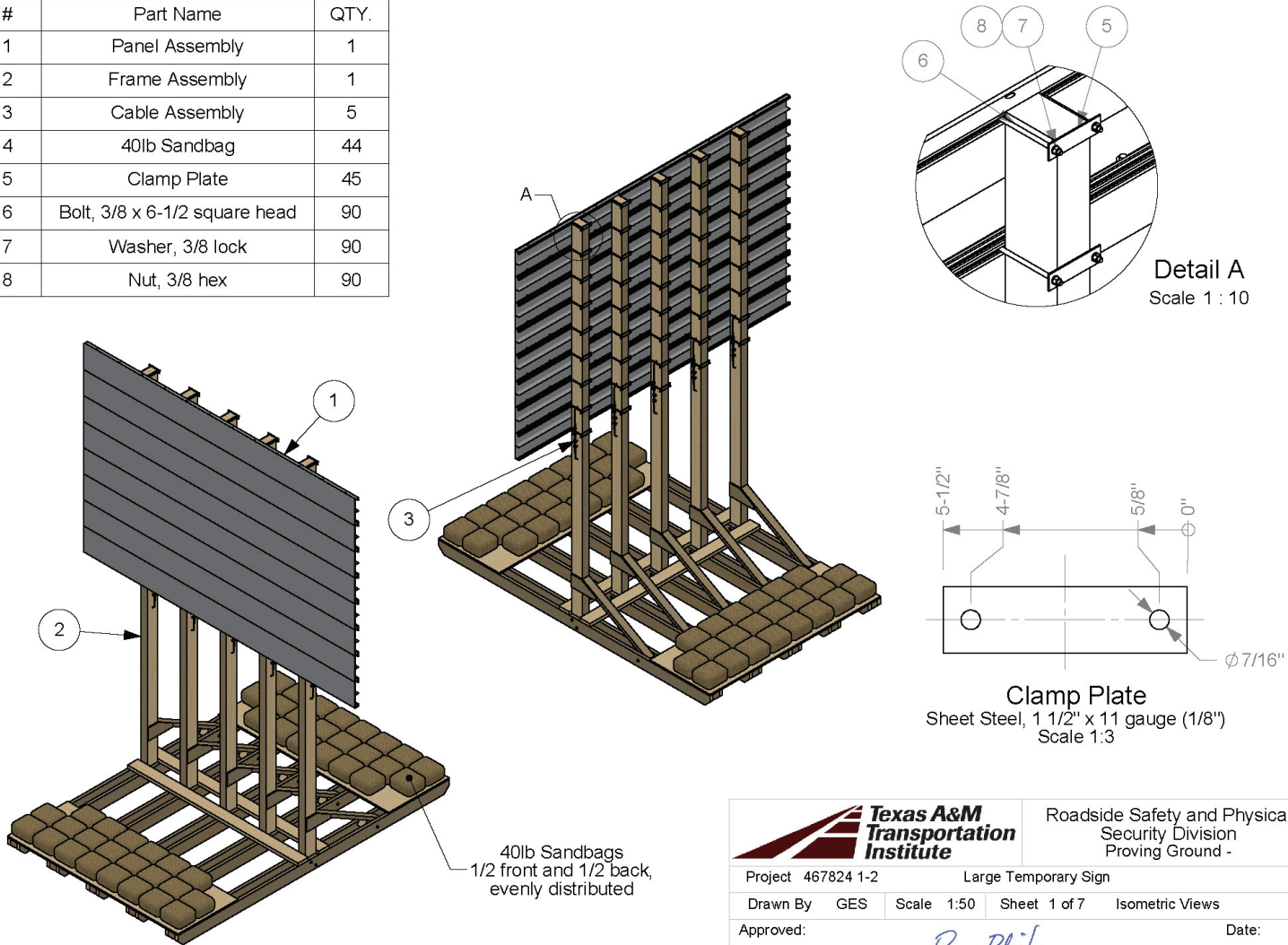

		Roadside Safety and Physical Security Division Proving Ground -	
Project	467824 1-2	Large Temporary Sign	
Drawn By	GES	Scale	1:50
		Sheet	1 of 7
		Isometric Views	
Approved:		Date:	
Roger Bligh:	<i>Roger Bligh</i>		2014-05-09

T:\2013-2014\467824 - TxDOT Temp Sign Support\467824-1\Drafting\467824 1-2 Drawing

APPENDIX A. DETAILS OF THE TEST ARTICLE  
FOR TEST NOS. 467824-1 AND 467824-2

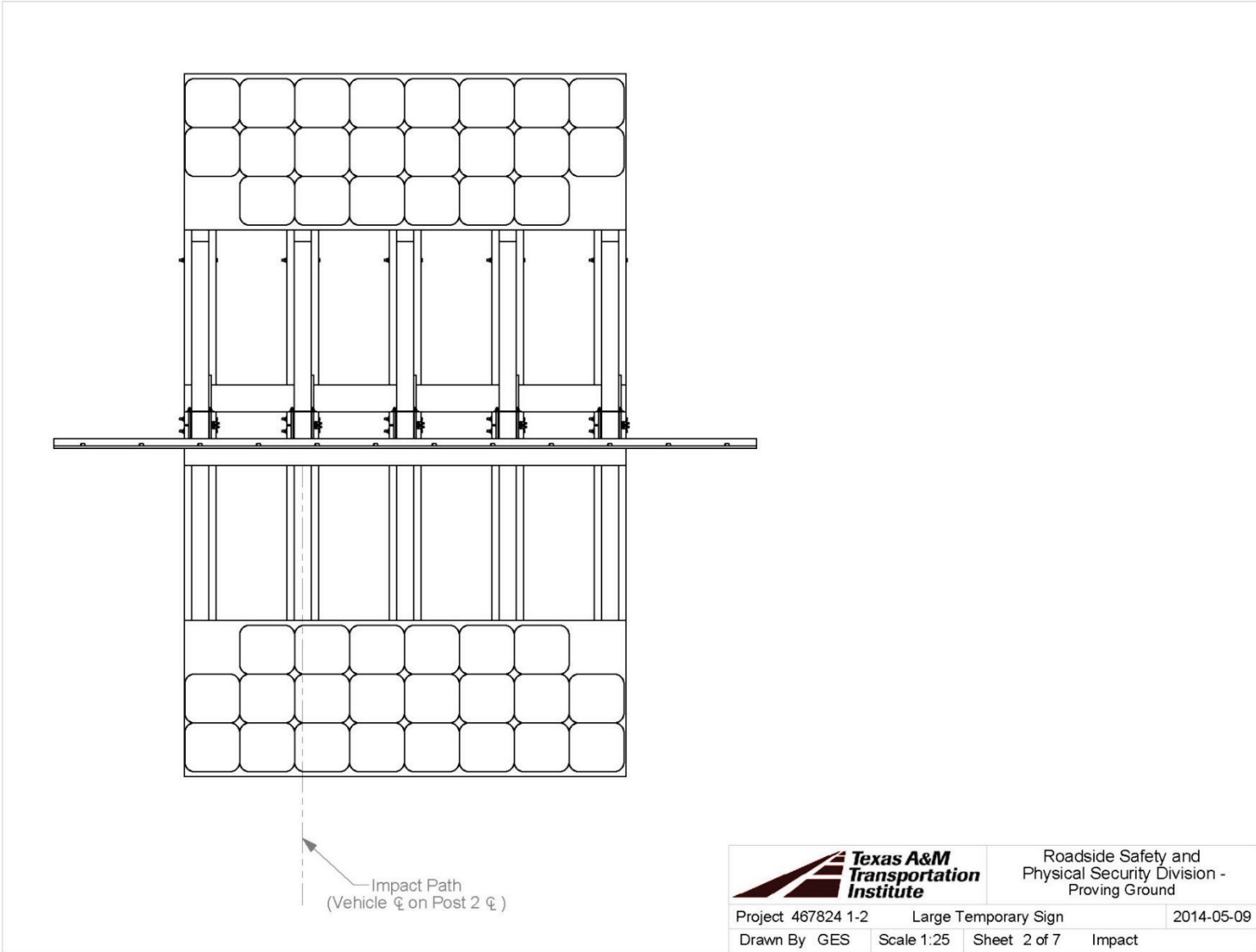

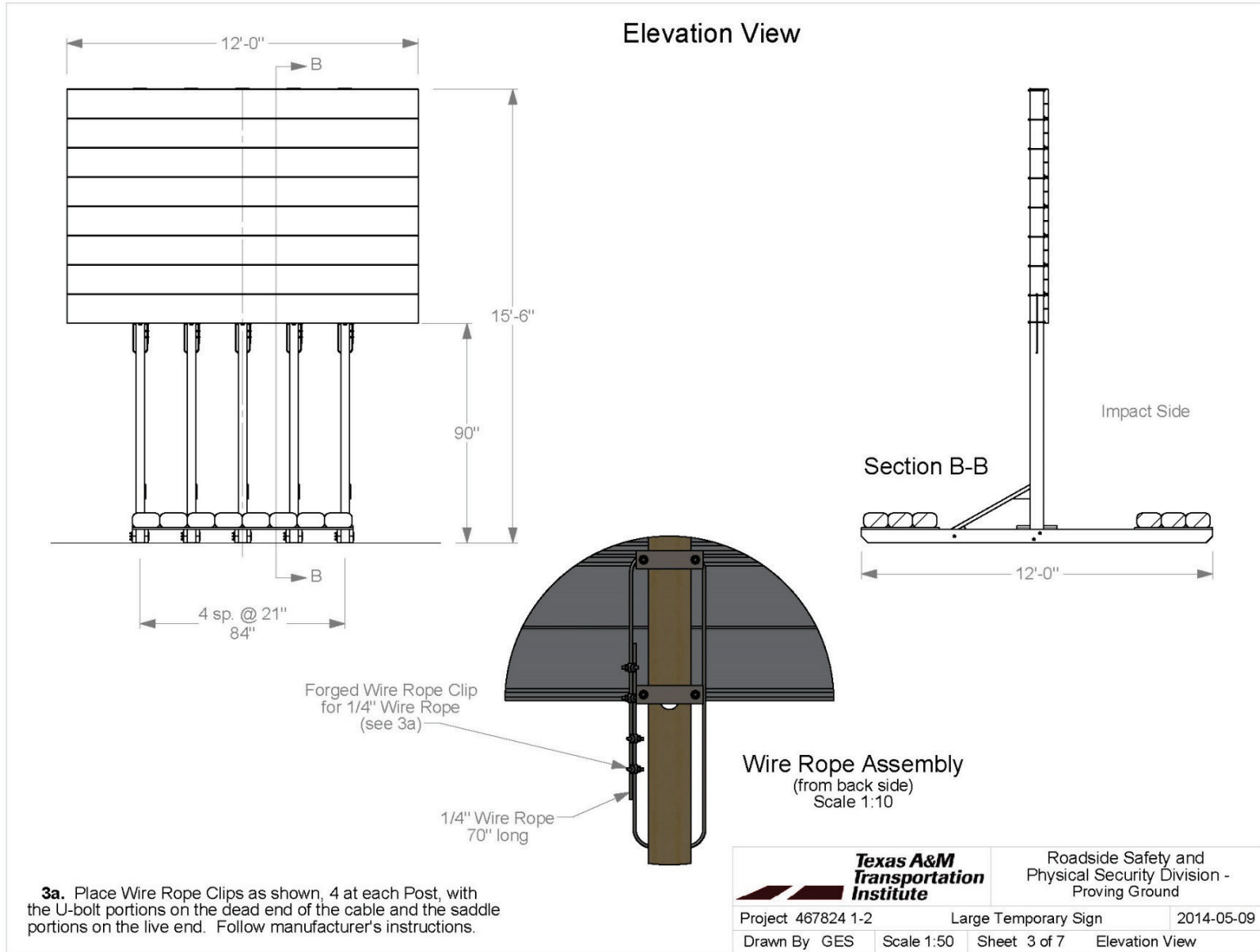

T:\2013-2014\467824 - TxDOT Temp Sign Support\467824-1\Drafting\467824 1-2 Drawing

**Panel Assembly**

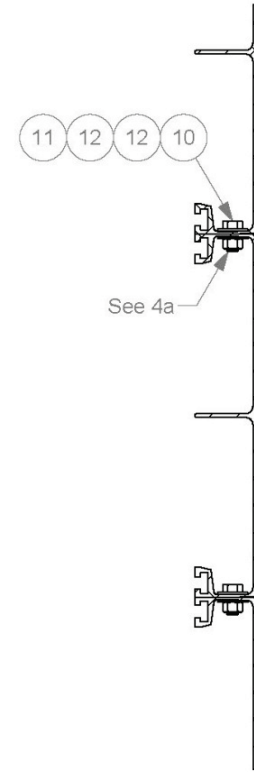
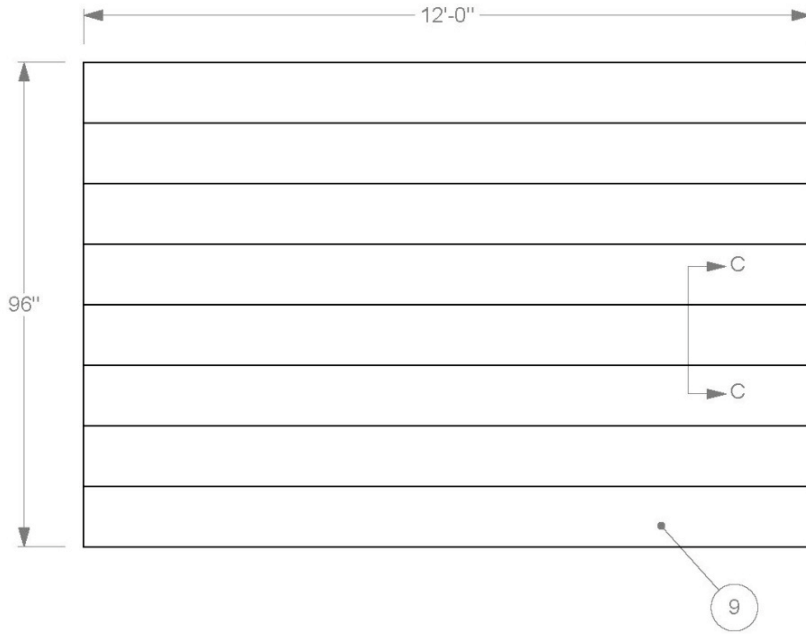

**Section C-C**  
Scale 1 : 5

Panel Assembly Parts		
#	Part Name	QTY.
9	Aluminum Sign Panel, 12" x 12'	8
10	Bolt, 3/8 x 3/4 hex	49
11	Nut, 3/8 hex	49
12	Washer, 3/8 flat	98

**4a.** At each joint at each end, and then at maximum  $\phi$  24" spacing.



Roadside Safety and  
Physical Security Division -  
Proving Ground

Project 467824 1-2	Large Temporary Sign	2014-05-09
Drawn By GES	Scale 1:30	Sheet 4 of 7 Panel Assembly

### Frame Assembly

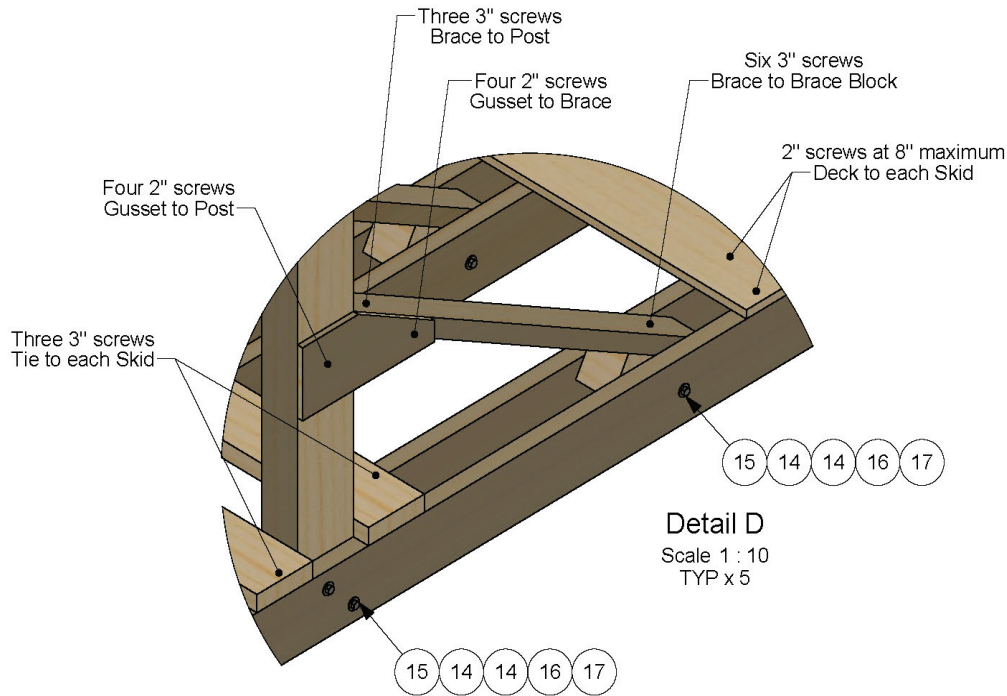

**Detail D**  
Scale 1 : 10  
TYP x 5

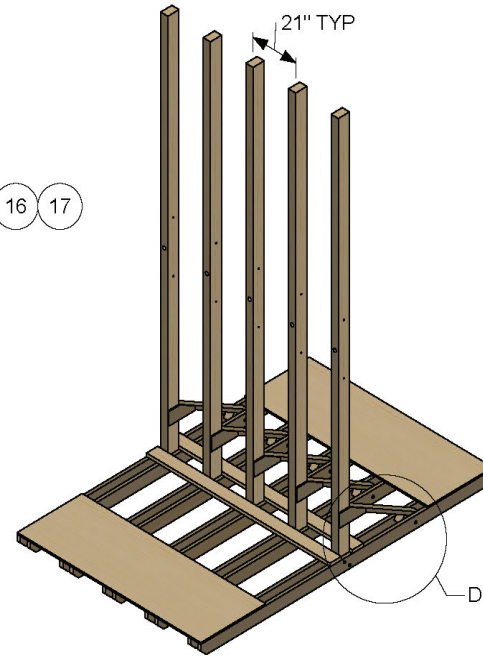

Frame Assembly Parts		
#	Part Name	QTY.
13	Wood Frame	1
14	Washer, 3/8 flat	30
15	Bolt, 3/8 x 7-1/2 hex	15
16	Washer, 3/8 lock	15
17	Nut, 3/8 hex	15
18	Deck Screws as needed*	

\*Use Deck Screws or other screws designed for outdoor use. Minimum size #8 for 2" screws and #9 for 3" screws. Drywall screws are not acceptable.



Roadside Safety and  
Physical Security Division -  
Proving Ground

Project 467824 1-2	Large Temporary Sign	2014-05-09
Drawn By GES	Scale 1:50	Sheet 5 of 7
Frame Assembly		

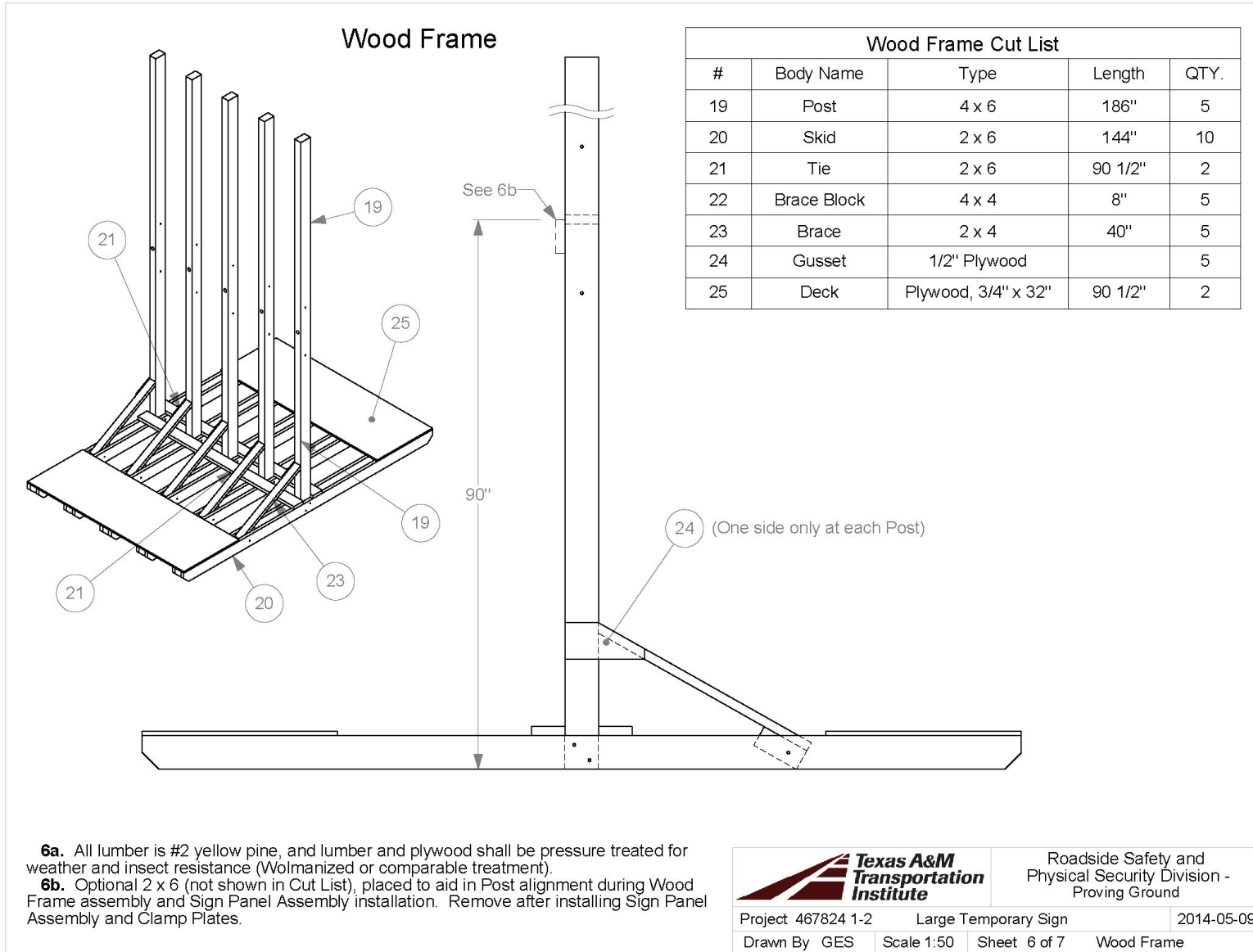

	Roadside Safety and Physical Security Division - Proving Ground	
	Project 467824 1-2	Large Temporary Sign
Drawn By GES	Scale 1:50	Sheet 6 of 7 Wood Frame

T:\2013-2014\467824 - TxDOT Temp Sign Support\467824-1\Drafting\467824 1-2 Drawing

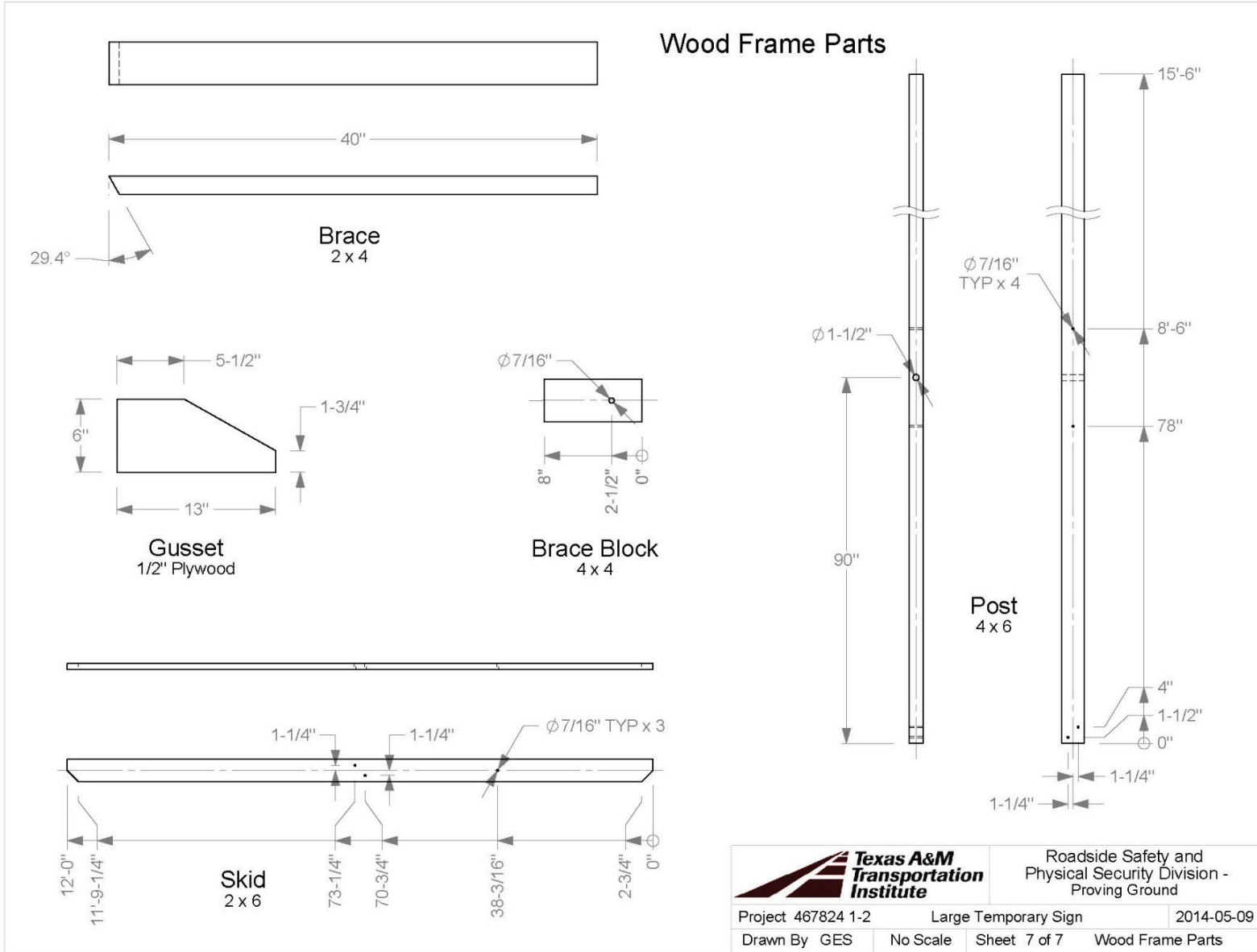

T:\2013-2014\467824 - TxDOT Temp Sign Support\467824-1\Drafting\467824 1-2 Drawing





**APPENDIX B. CERTIFICATION DOCUMENTATION FOR TEST NOS.  
467824-1 AND 467824-2**

TEST NUMBER	467824 1-2
TEST NAME	TxDOT Temporary Signs
DATE	2014-05-15

No paperwork is available for the material used for these tests.



# APPENDIX C. CRASH TEST DATA AND INFORMATION FOR TEST NO. 467824-1

## C1. VEHICLE INFORMATION

**Table C1. Vehicle Properties for Test No. 467824-1.**

Date: 2014-05-15 Test No.: 467824-1 VIN No.: KNAD123786319787  
 Year: 2008 Make: Kia Model: Rio  
 Tire Inflation Pressure: 32 psi Odometer: 112475 Tire Size: 185/65R14  
 Describe any damage to the vehicle prior to test: None

● Denotes accelerometer location.

NOTES: None

Engine Type: 4 cylinder  
 Engine CID: 1.6 liter  
 Transmission Type:  
 Auto or  Manual  
 FWD  RWD  4WD  
 Optional Equipment:  
NA

Dummy Data:  
 Type: 50<sup>th</sup> percentile male  
 Mass: 165 lb  
 Seat Position: Driver side

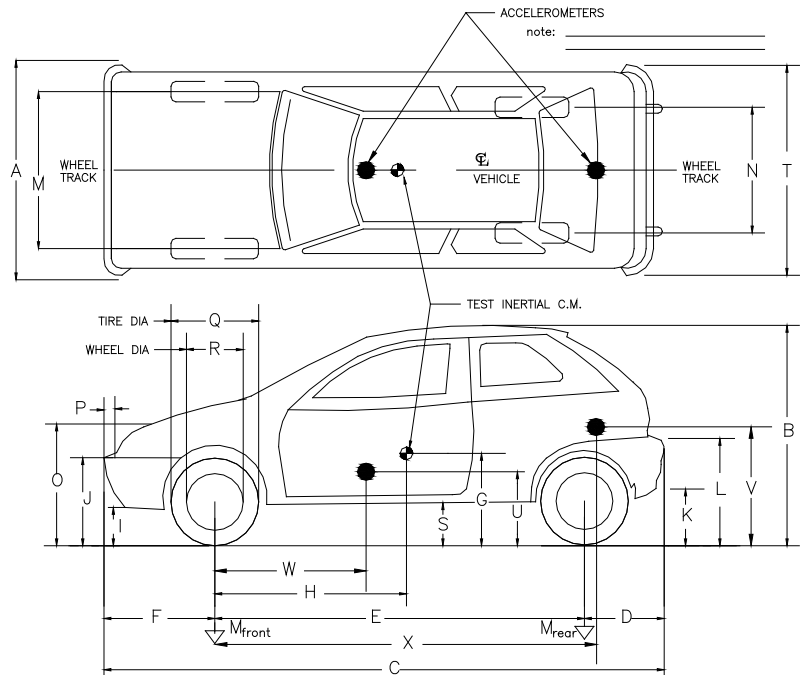

**Geometry:** inches

A	<u>66.38</u>	F	<u>33.00</u>	K	<u>11.75</u>	P	<u>44.12</u>	U	<u>14.50</u>
B	<u>58.25</u>	G	<u>----</u>	L	<u>25.00</u>	Q	<u>22.18</u>	V	<u>21.50</u>
C	<u>165.75</u>	H	<u>35.25</u>	M	<u>57.75</u>	R	<u>15.38</u>	W	<u>44.00</u>
D	<u>34.00</u>	I	<u>8.00</u>	N	<u>57.12</u>	S	<u>9.00</u>	X	<u>108.00</u>
E	<u>98.75</u>	J	<u>21.00</u>	O	<u>31.00</u>	T	<u>66.12</u>		

Wheel Center Ht Front 11.00 Wheel Center Ht Rear 11.00

<b>GVWR Ratings:</b>	<b>Mass: lb</b>	<b>Curb</b>	<b>Test Inertial</b>	<b>Gross Static</b>
Front	<u>1918</u>	$M_{front}$	<u>1607</u>	<u>1650</u>
Back	<u>1874</u>	$M_{rear}$	<u>903</u>	<u>955</u>
Total	<u>3638</u>	$M_{Total}$	<u>2510</u>	<u>2605</u>

**Mass Distribution:**

lb LF: 799 RF: 770 LR: 448 RR: 423



**Table C3. Occupant Compartment Measurements for Test No. 467824-1.**

Date: 2014-05-15 Test No.: 467824-1 VIN No.: KNADE123786319787  
 Year: 2008 Make: Kia Model: Rio

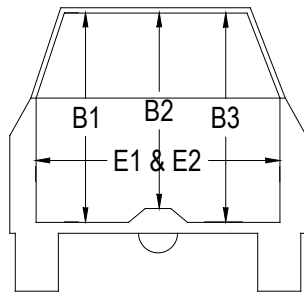
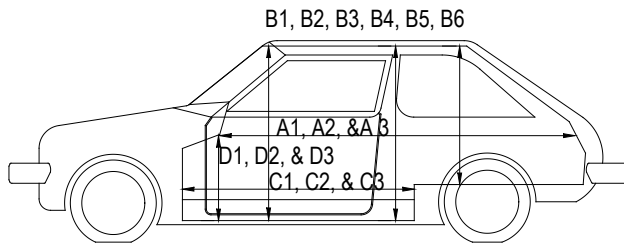
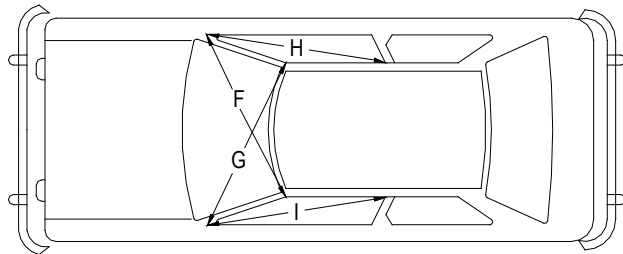

**OCCUPANT COMPARTMENT DEFORMATION MEASUREMENT**

	<b>Before</b> ( inches )	<b>After</b> ( inches )
A1	68.00	68.00
A2	67.50	67.50
A3	68.00	68.00
B1	40.50	40.50
B2	36.25	36.25
B3	40.50	40.50
B4	36.25	36.25
B5	32.50	32.50
B6	36.25	36.25
C1	28.00	28.00
C2	----	----
C3	26.75	26.75
D1	9.75	9.75
D2	----	----
D3	9.50	9.50
E1	51.50	51.50
E2	51.25	51.25
F	50.25	50.25
G	50.25	50.25
H	38.00	38.00
I	38.00	38.00
J*	51.00	51.00

\*Lateral area across the cab from driver's side kickpanel to passenger's side kickpanel.

## C2. SEQUENTIAL PHOTOGRAPHS



0.000 s



0.189 s



0.377 s



0.566 s

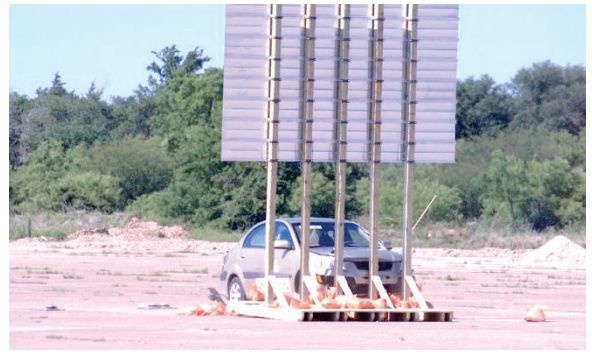

**Figure C1. Sequential Photographs for Test No. 467824-1 (Perpendicular and Oblique Views).**





0.754s



0.943 s



1.131 s



1.320 s



**Figure C1. Sequential Photographs for Test No. 467824-1 (Perpendicular and Oblique Views) (Continued).**



### Roll, Pitch, and Yaw Angles

C3. VEHICLE ANGULAR DISPLACEMENTS

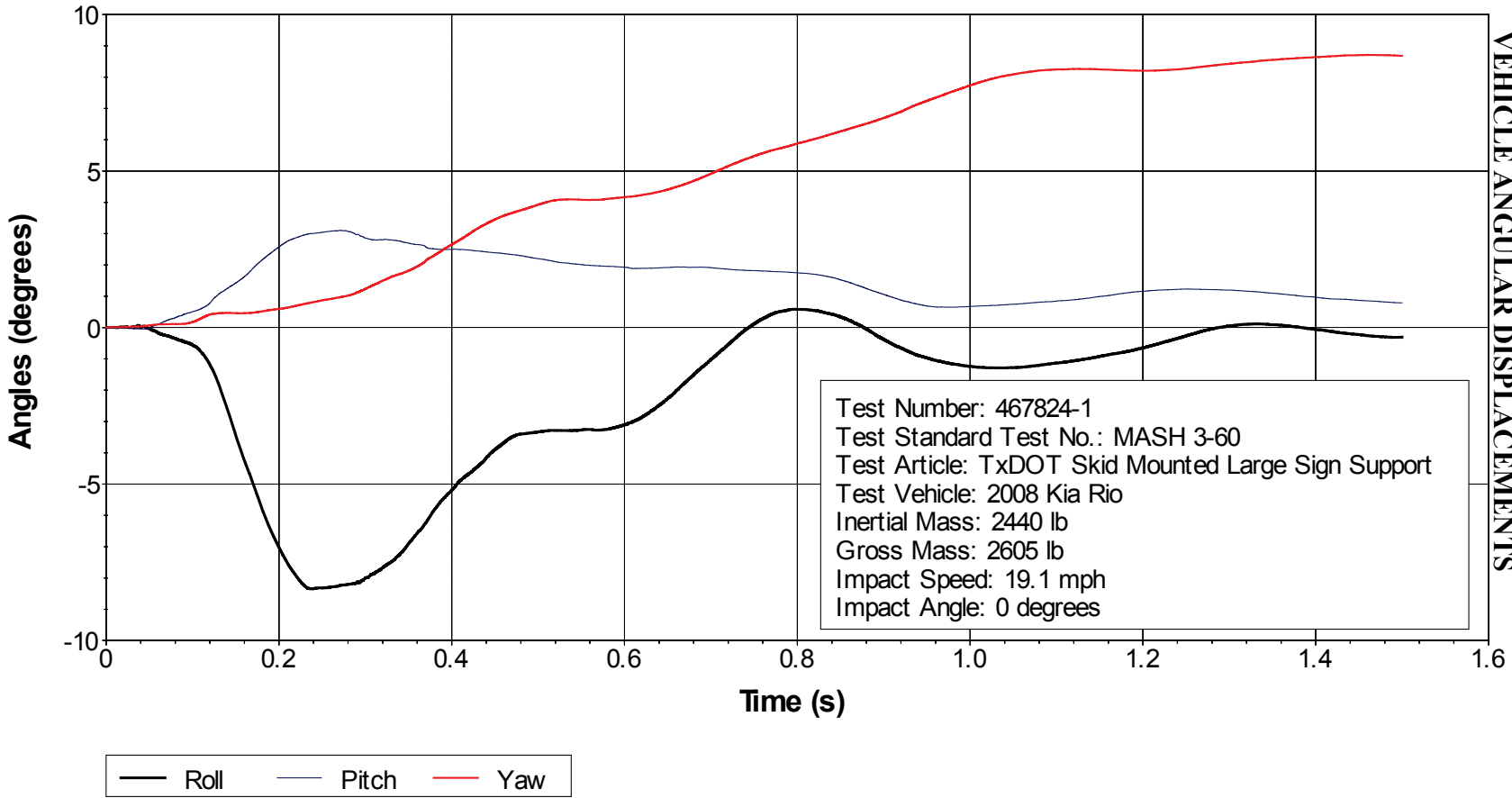
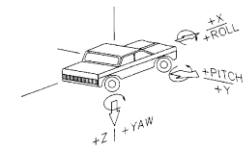

Figure C2. Vehicle Angular Displacements for Test No. 467824-1.



### X Acceleration at CG

C4. VEHICLE ACCELERATIONS

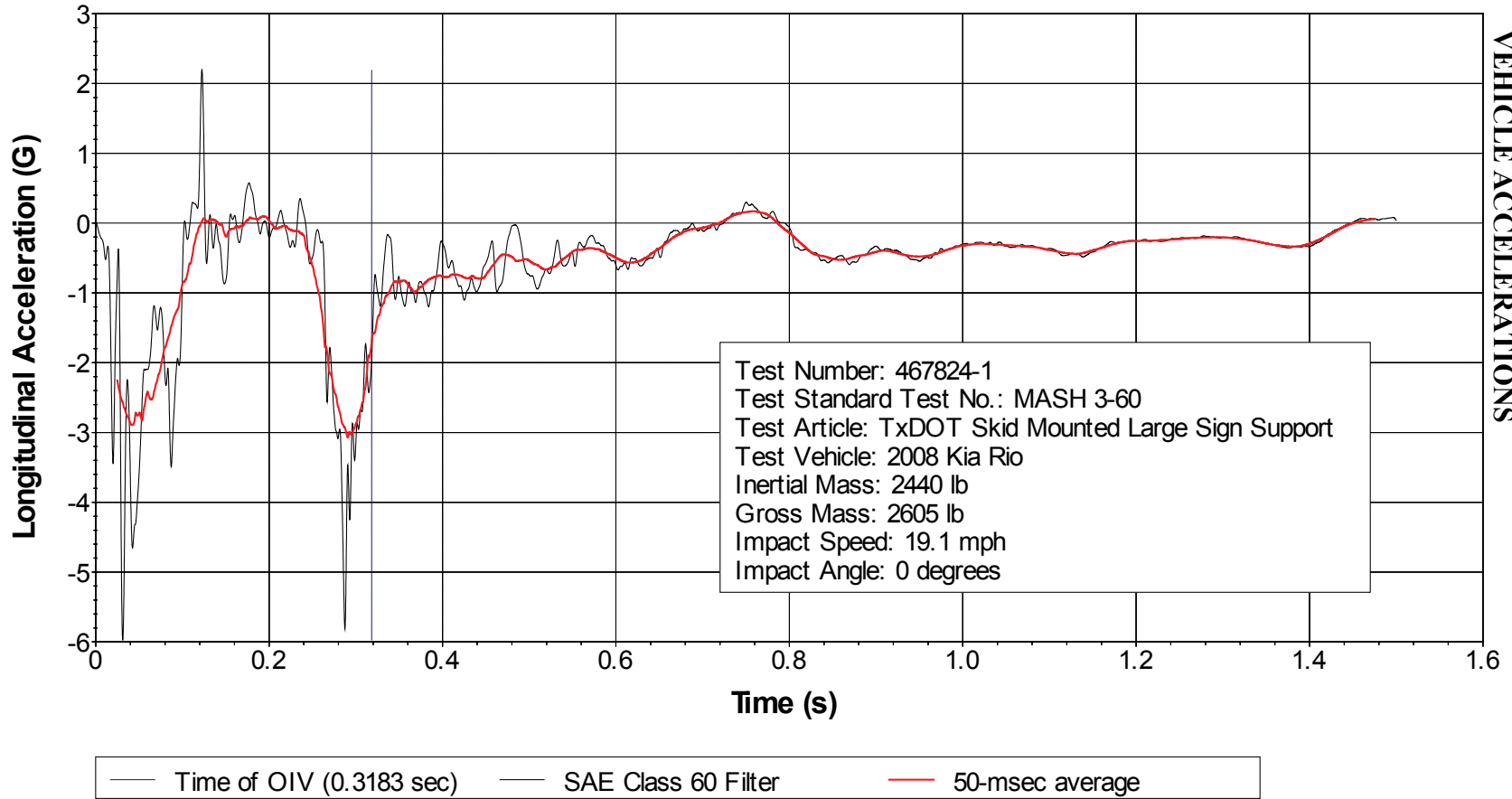
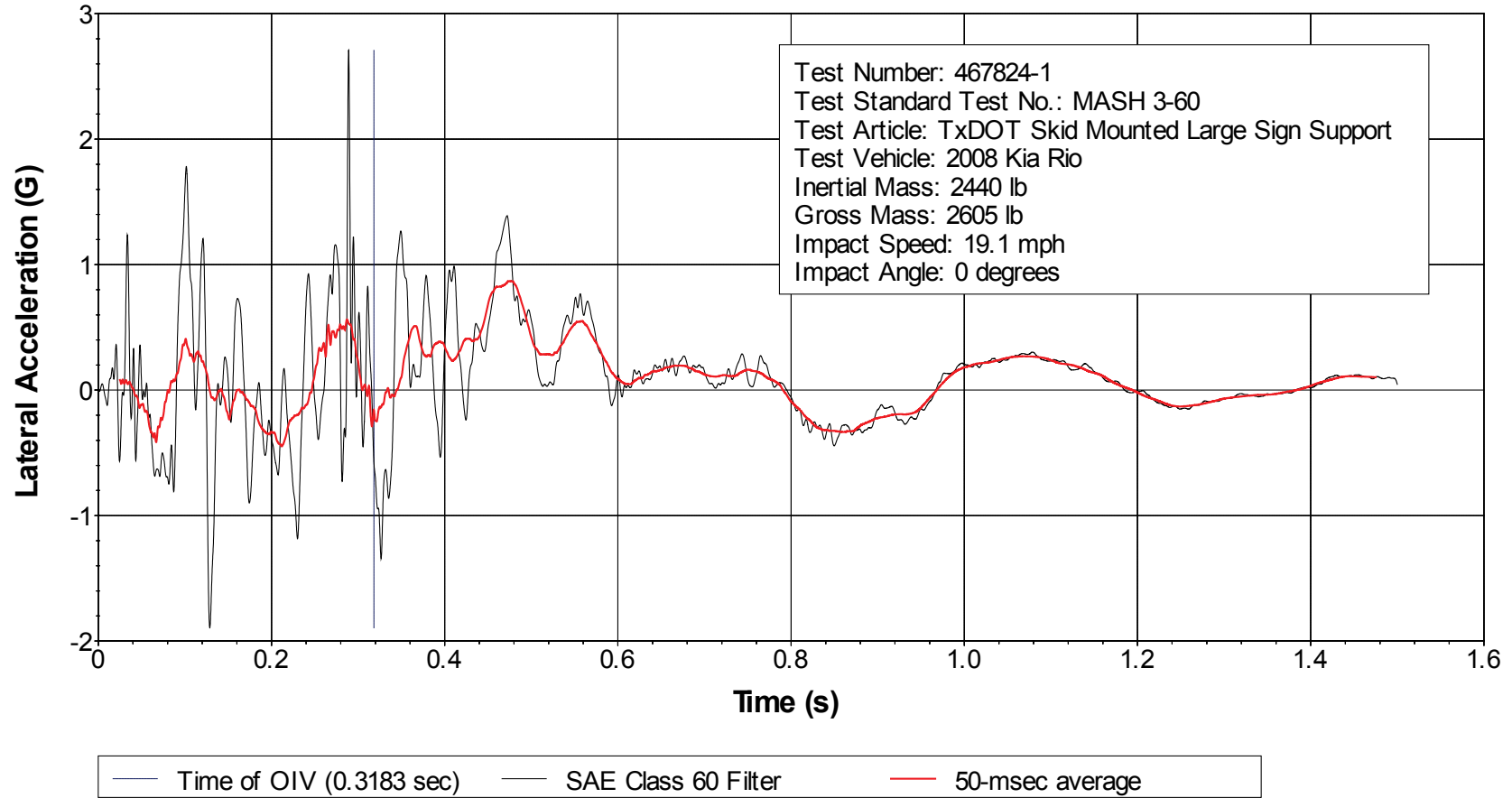

Figure C3. Vehicle Longitudinal Accelerometer Trace for Test No. 467824-1 (Accelerometer Located at Center of Gravity).

### Y Acceleration at CG



**Figure C4. Vehicle Lateral Accelerometer Trace for Test No. 467824-1 (Accelerometer Located at Center of Gravity).**

### Z Acceleration at CG

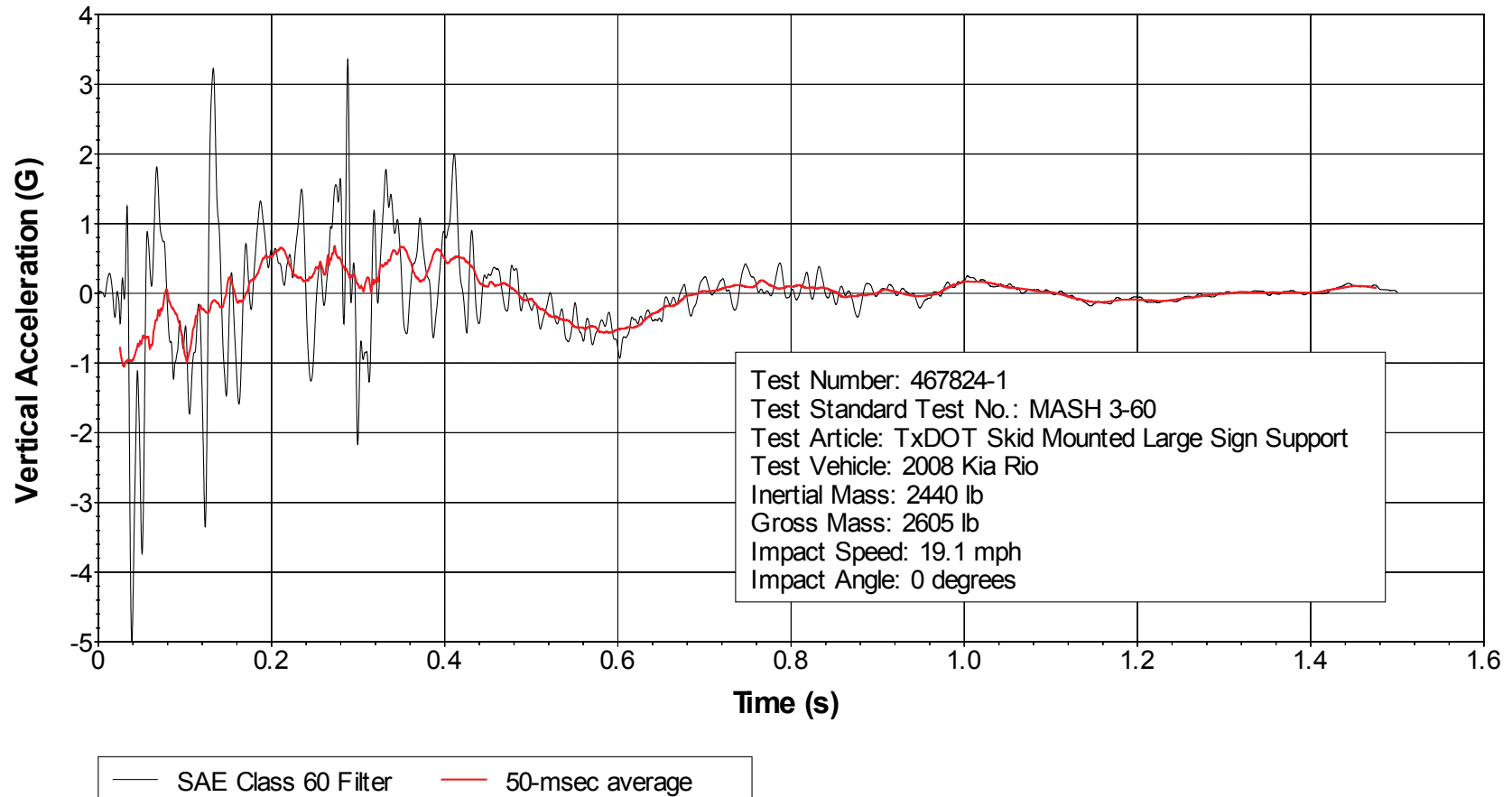

**Figure C5. Vehicle Vertical Accelerometer Trace for Test No. 467824-1 (Accelerometer Located at Center of Gravity).**

### X Acceleration Rear of CG

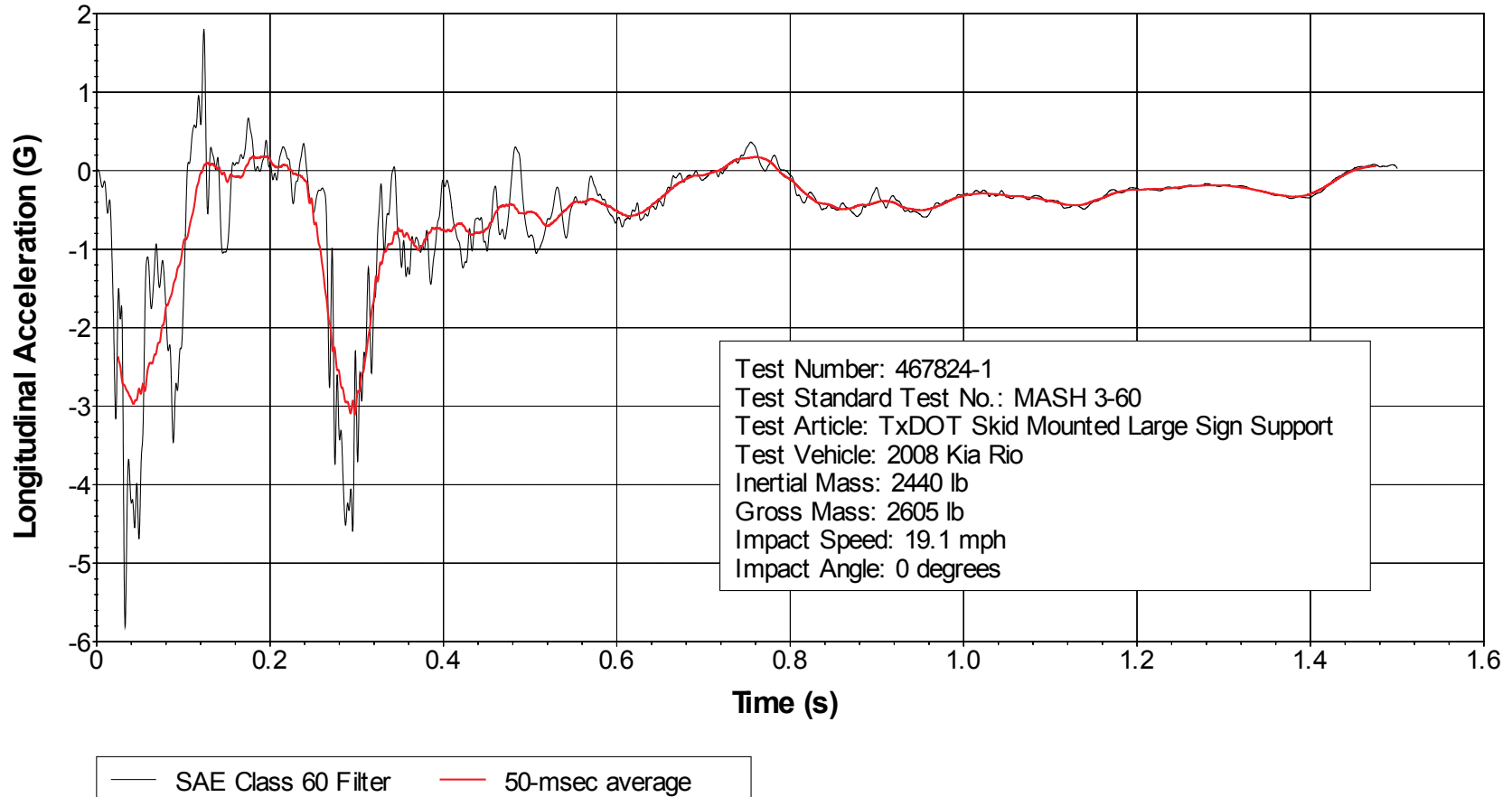

**Figure C6. Vehicle Longitudinal Accelerometer Trace for Test No. 467824-1 (Accelerometer Located Rear of Center of Gravity).**

### Y Acceleration Rear of CG

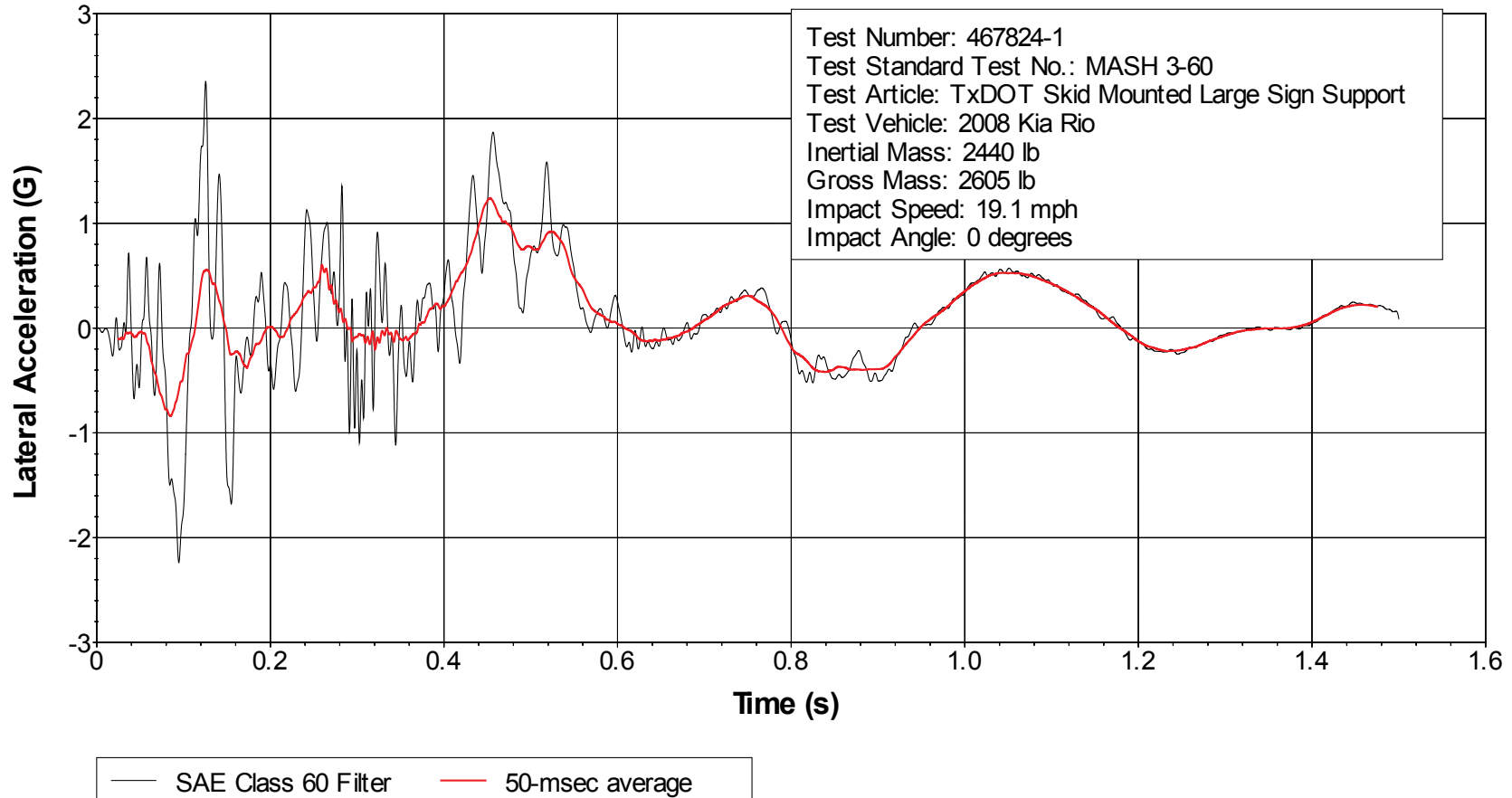

**Figure C7. Vehicle Lateral Accelerometer Trace for Test No. 467824-1 (Accelerometer Located Rear of Center of Gravity).**



### Z Acceleration Rear of CG

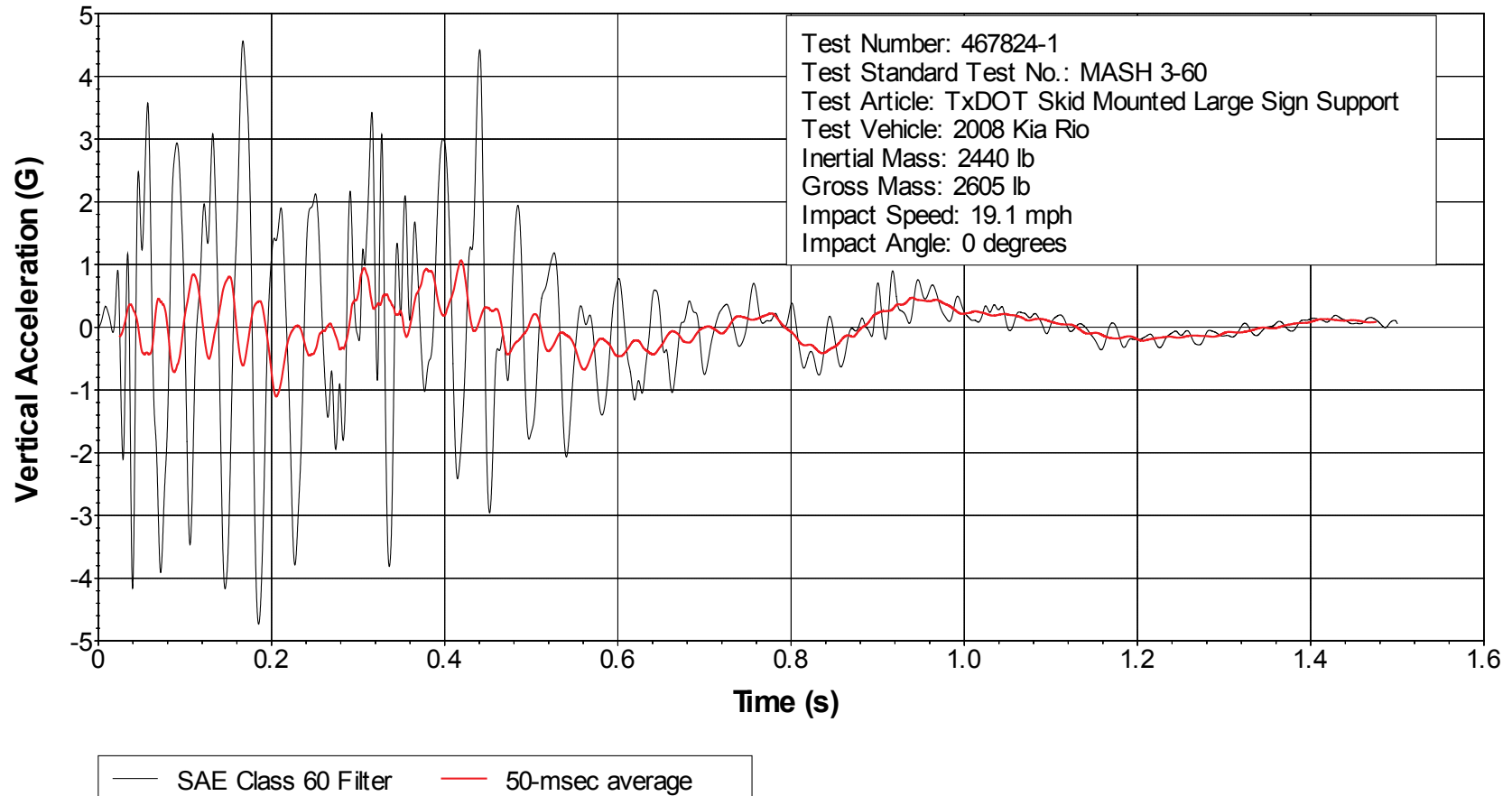

**Figure C8. Vehicle Vertical Accelerometer Trace for Test No. 467824-1 (Accelerometer Located Rear of Center of Gravity).**

# APPENDIX D. CRASH TEST DATA AND INFORMATION FOR TEST NO. 467824-2

## D1. VEHICLE INFORMATION

**Table D1. Vehicle Properties for Test No. 467824-2.**

Date: 2014-05-15 Test No.: 467824-2 VIN No.: KNADE123986388920  
 Year: 2008 Make: Kia Model: Rio  
 Tire Inflation Pressure: 32 psi Odometer: 102580 Tire Size: 185/65R14  
 Describe any damage to the vehicle prior to test: None

• Denotes accelerometer location.

NOTES: None

Engine Type: 4 cylinder  
 Engine CID: 1.6 liter  
 Transmission Type:  
Auto or x Manual  
x FWD RWD 4WD  
 Optional Equipment:  
NA

Dummy Data:  
 Type: 50<sup>th</sup> percentile male  
 Mass: 165 lb  
 Seat Position: Driver side

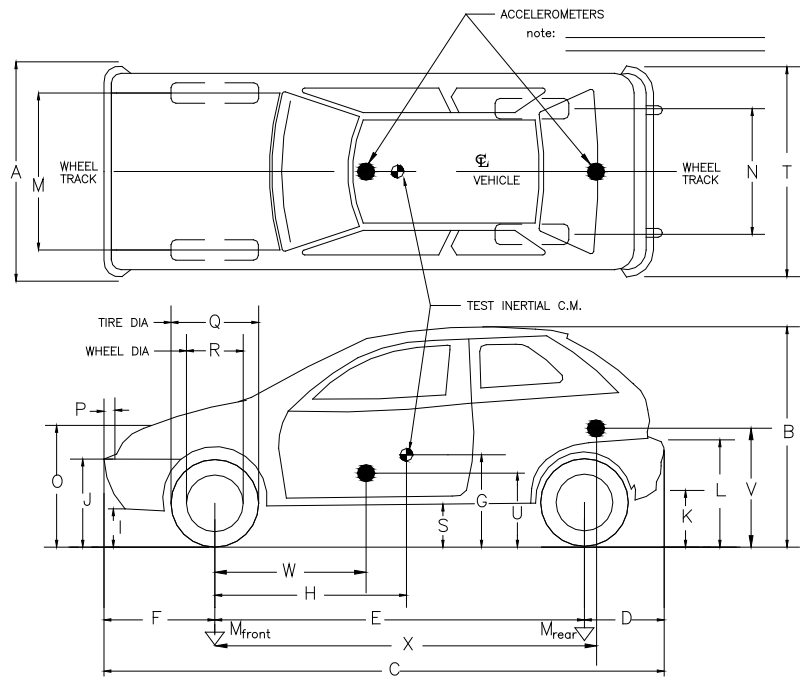

**Geometry:** inches

A	<u>66.36</u>	F	<u>33.00</u>	K	<u>11.75</u>	P	<u>4.12</u>	U	<u>14.50</u>
B	<u>58.25</u>	G	<u>-----</u>	L	<u>25.00</u>	Q	<u>22.18</u>	V	<u>21.00</u>
C	<u>165.75</u>	H	<u>35.51</u>	M	<u>57.75</u>	R	<u>15.38</u>	W	<u>44.00</u>
D	<u>34.00</u>	I	<u>8.75</u>	N	<u>57.12</u>	S	<u>8.50</u>	X	<u>109.00</u>
E	<u>98.75</u>	J	<u>21.00</u>	O	<u>31.75</u>	T	<u>66.12</u>		
Wheel Center Ht Front	<u>11.00</u>	Wheel Center Ht Rear	<u>11.00</u>						

GVWR Ratings:	Mass: lb	Curb	Test Inertial	Gross Static
Front <u>1918</u>	$M_{front}$ <u>1529</u>	<u>1529</u>	<u>1553</u>	<u>1640</u>
Back <u>1874</u>	$M_{rear}$ <u>873</u>	<u>873</u>	<u>872</u>	<u>950</u>
Total <u>3638</u>	$M_{Total}$ <u>2402</u>	<u>2402</u>	<u>2425</u>	<u>2590</u>

**Mass Distribution:**  
 lb LF: 770 RF: 783 LR: 441 RR: 431



**Table D3. Occupant Compartment Measurements for Test No. 467824-2.**

Date: 2014-05-15 Test No.: 467824-2 VIN No.: KNADE123986388920  
 Year: 2008 Make: Kia Model: Rio

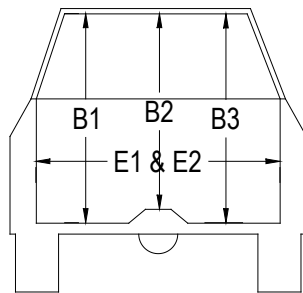
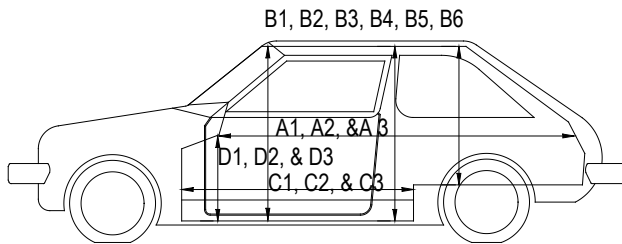
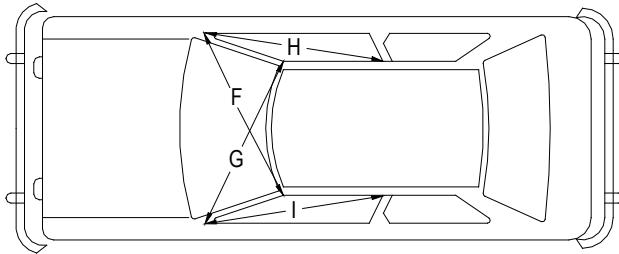

**OCCUPANT COMPARTMENT DEFORMATION MEASUREMENT**

	<b>Before</b> ( inches )	<b>After</b> ( inches )
A1	68.00	68.00
A2	67.50	67.50
A3	68.00	68.00
B1	40.50	40.50
B2	36.25	36.25
B3	40.50	35.25
B4	36.25	30.50
B5	32.50	32.50
B6	36.25	36.25
C1	25.50	25.50
C2	-----	-----
C3	27.75	27.75
D1	9.50	9.50
D2	-----	-----
D3	9.75	9.75
E1	51.50	51.50
E2	51.00	51.00
F	50.50	50.50
G	50.50	50.50
H	38.00	38.00
I	38.00	38.00
J*	50.50	50.50

\*Lateral area across the cab from driver's side kickpanel to passenger's side kickpanel.

## D2. SEQUENTIAL PHOTOGRAPHS



0.000 s



0.065 s



0.130 s

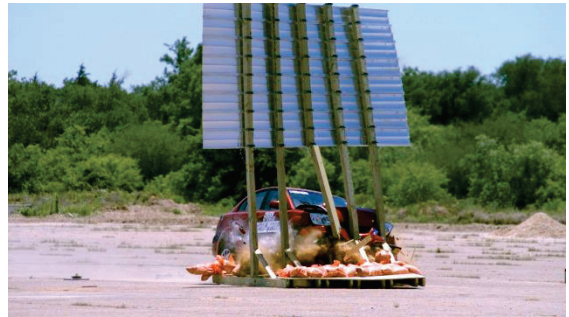

0.195 s



**Figure D1. Sequential Photographs for Test No. 467824-2 (Perpendicular and Oblique Views).**





0.259s



0.324 s

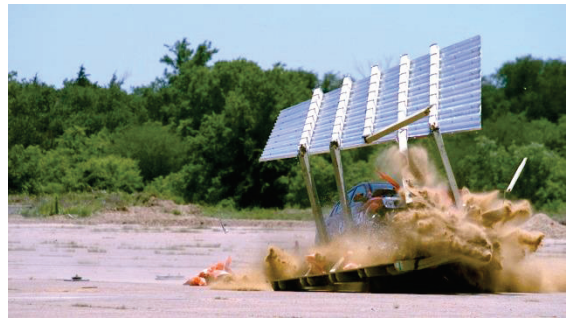

0.389 s



0.454 s



**Figure D1. Sequential Photographs for Test No. 467824-2 (Perpendicular and Oblique Views) (Continued).**

### Roll, Pitch, and Yaw Angles

D3. VEHICLE ANGULAR DISPLACEMENTS

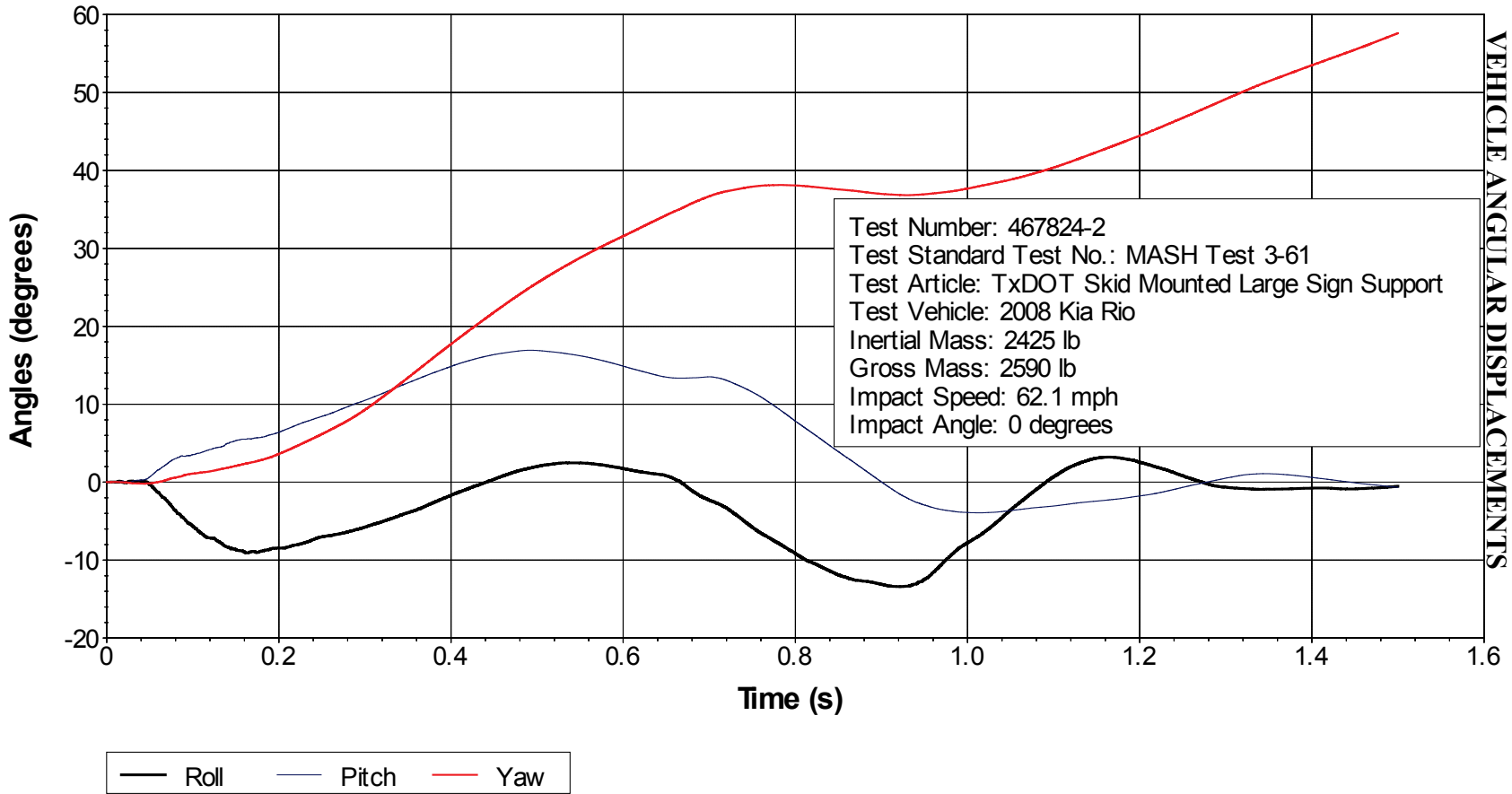
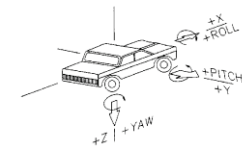

Figure D2. Vehicle Angular Displacements for Test No. 467824-2.





### X Acceleration at CG

D4. VEHICLE ACCELERATIONS

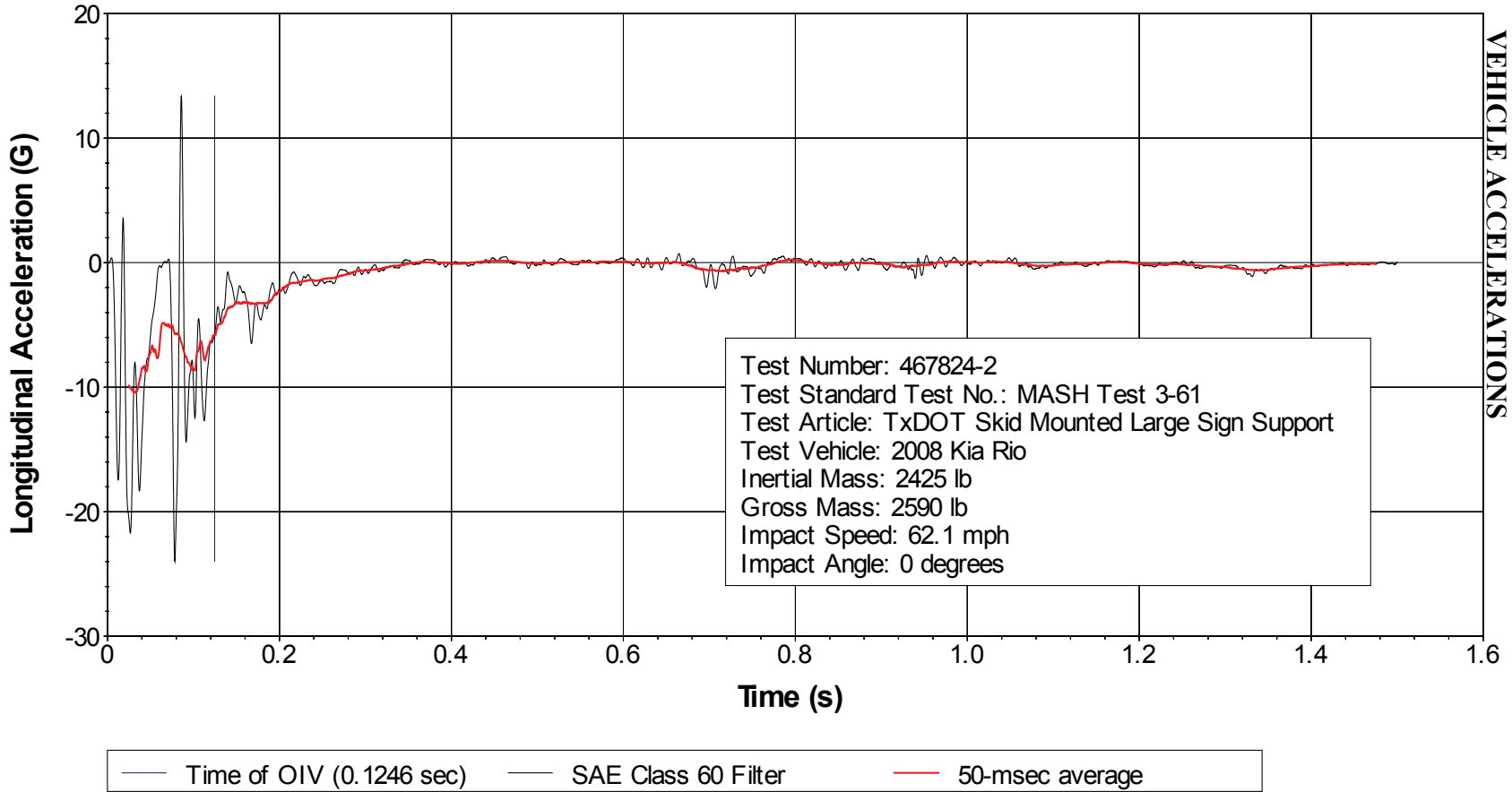
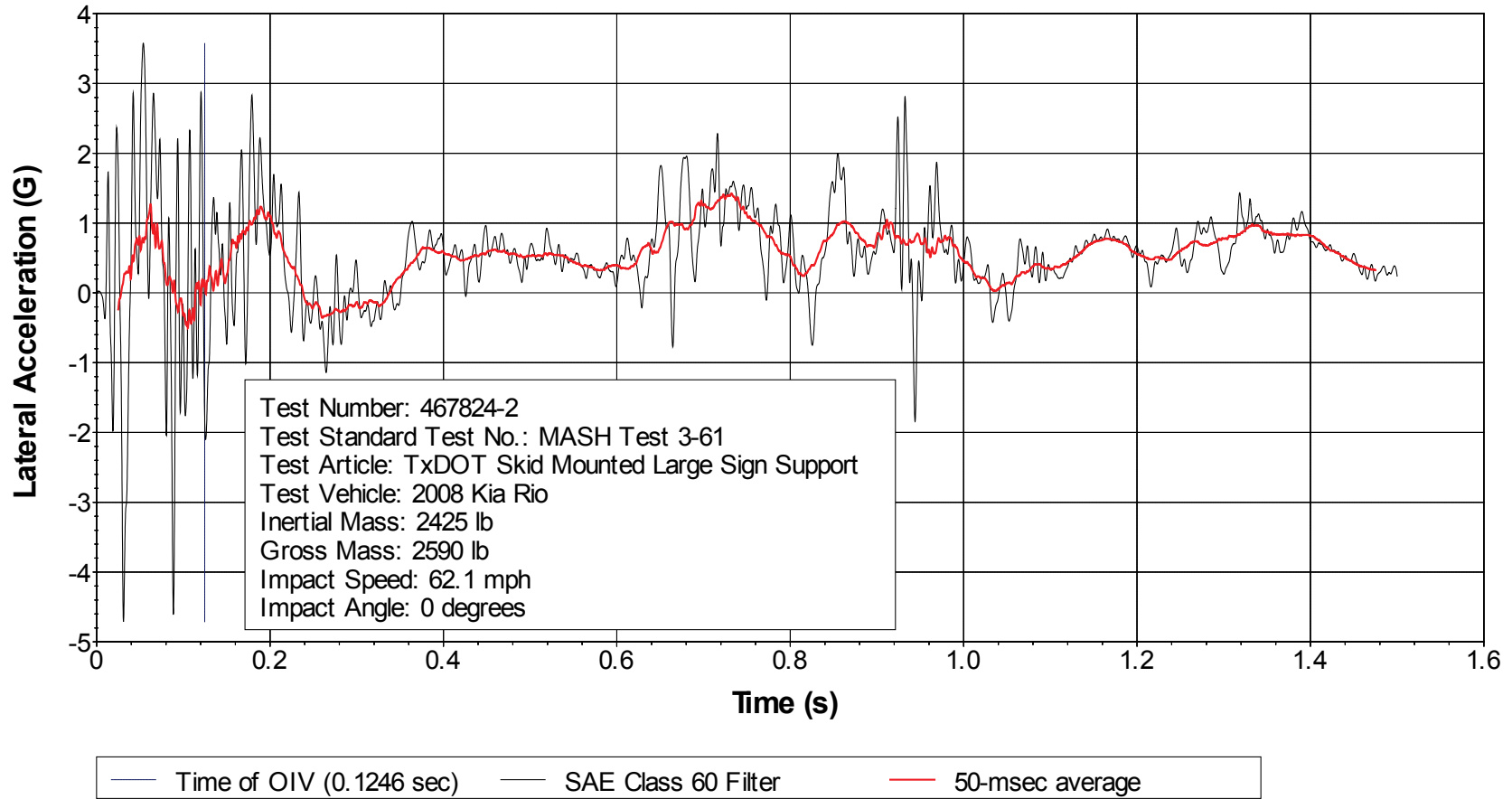

Figure D3. Vehicle Longitudinal Accelerometer Trace for Test No. 467824-2 (Accelerometer Located at Center of Gravity).

### Y Acceleration at CG



**Figure D4. Vehicle Lateral Accelerometer Trace for Test No. 467824-2 (Accelerometer Located at Center of Gravity).**

### Z Acceleration at CG

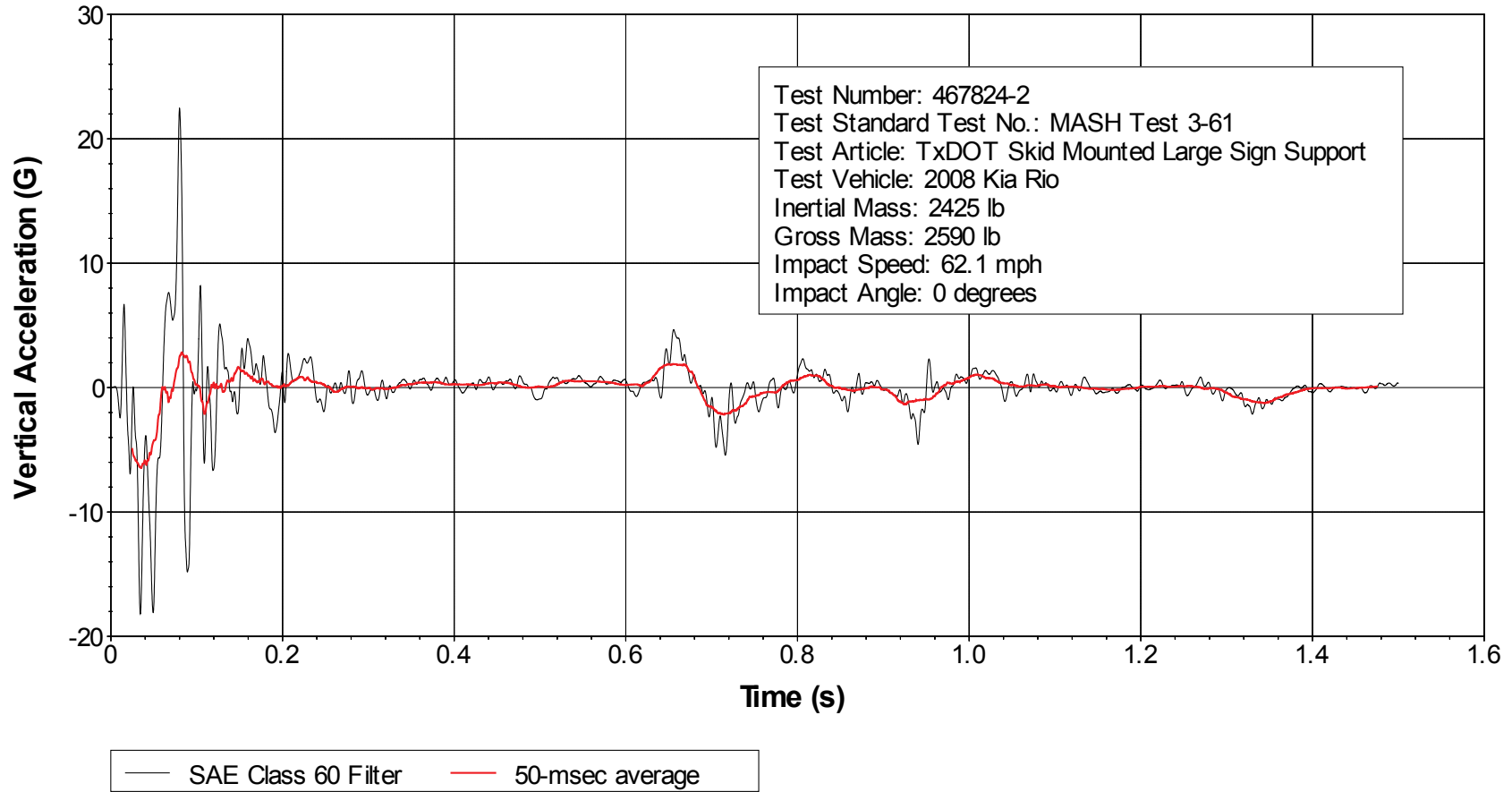

**Figure D5. Vehicle Vertical Accelerometer Trace for Test No. 467824-2 (Accelerometer Located at Center of Gravity).**

### X Acceleration Rear of CG

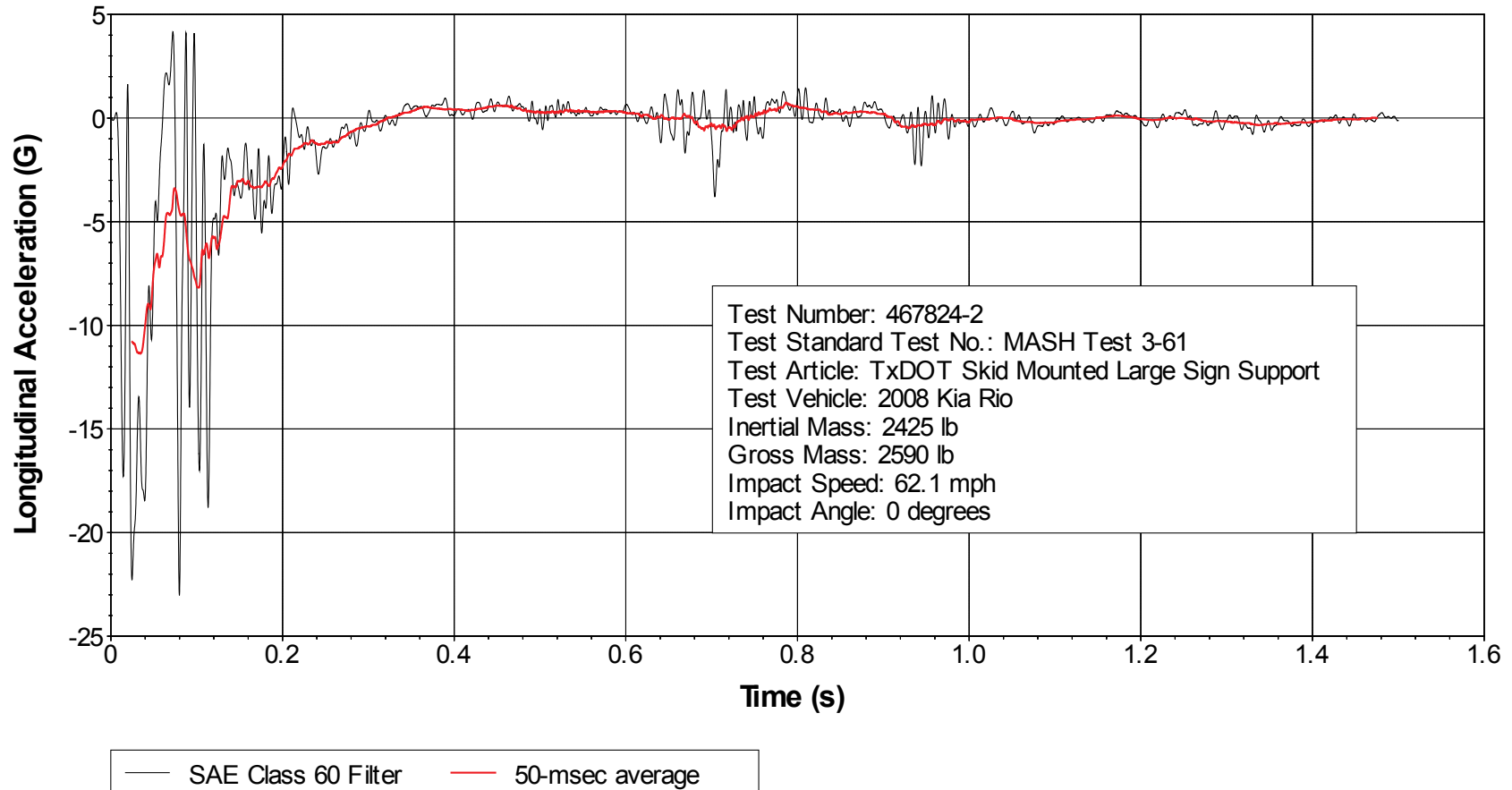

**Figure D6. Vehicle Longitudinal Accelerometer Trace for Test No. 467824-2 (Accelerometer Located Rear of Center of Gravity).**

### Y Acceleration Rear of CG

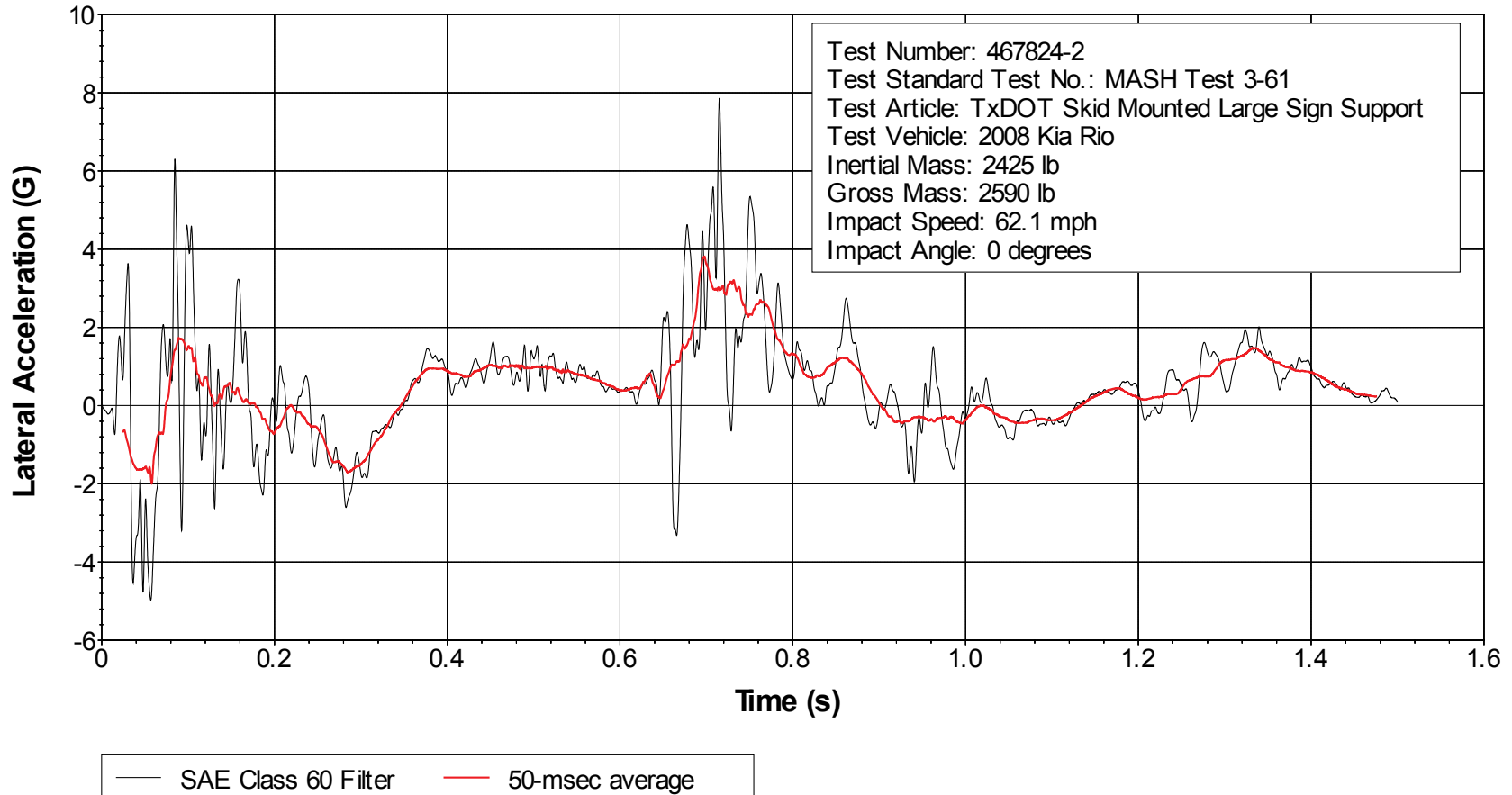

**Figure D7. Vehicle Lateral Accelerometer Trace for Test No. 467824-2 (Accelerometer Located Rear of Center of Gravity).**

### Z Acceleration Rear of CG

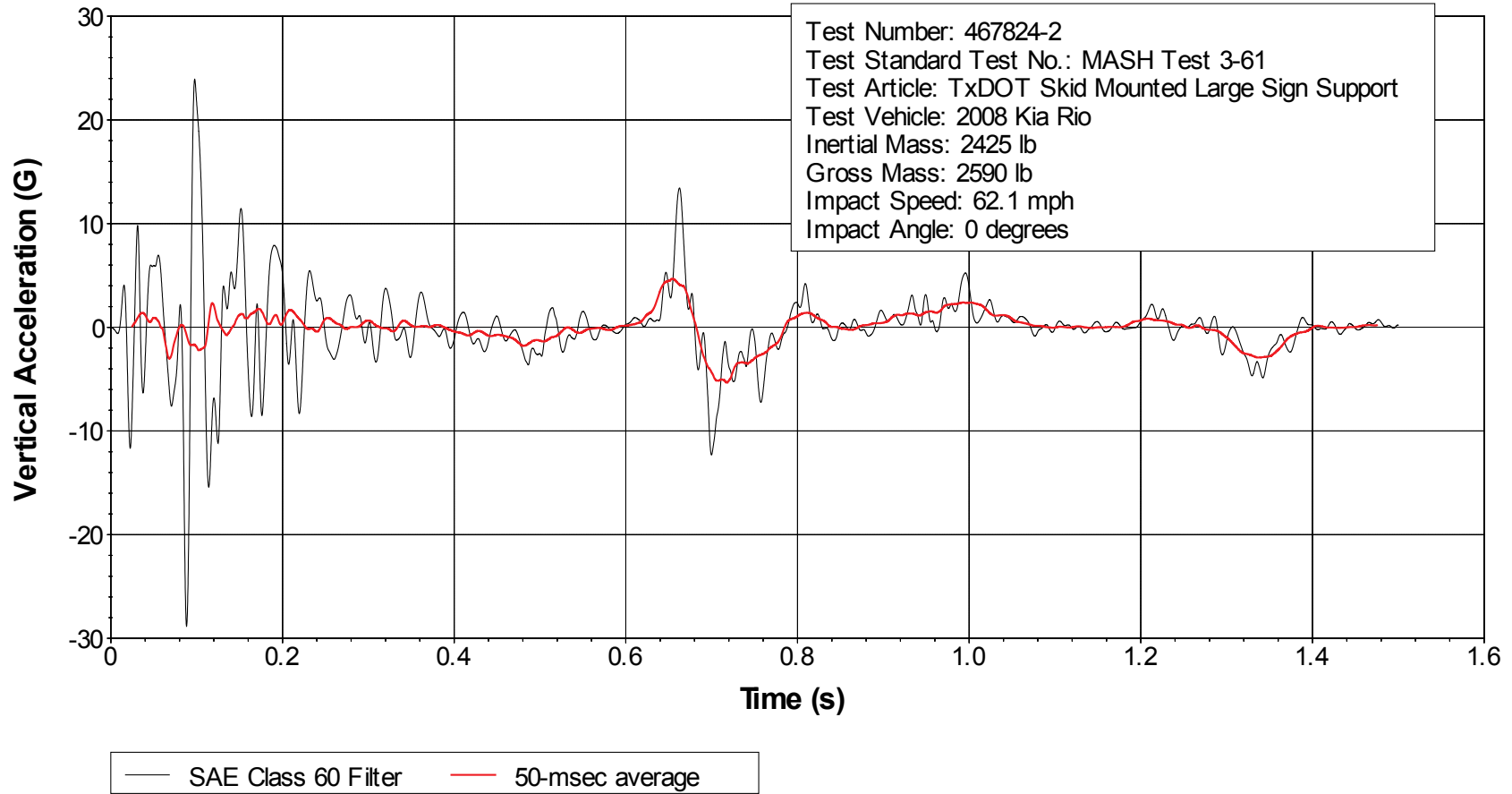
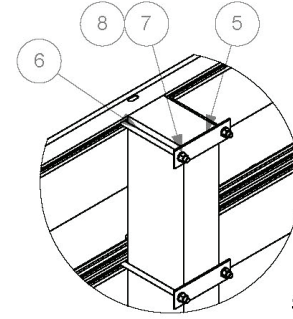
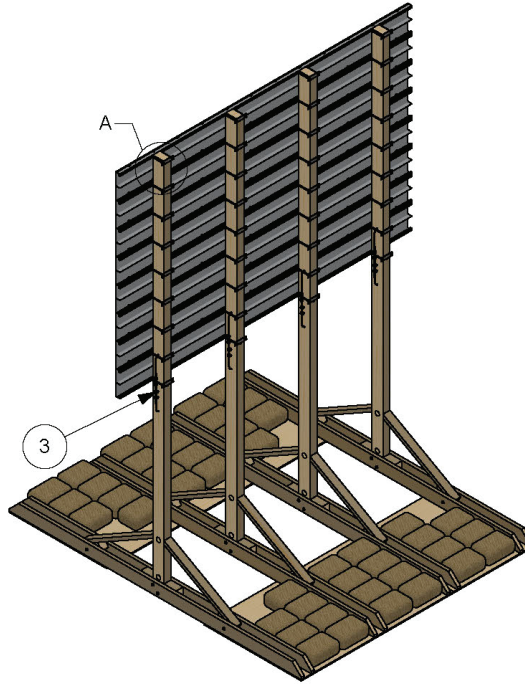
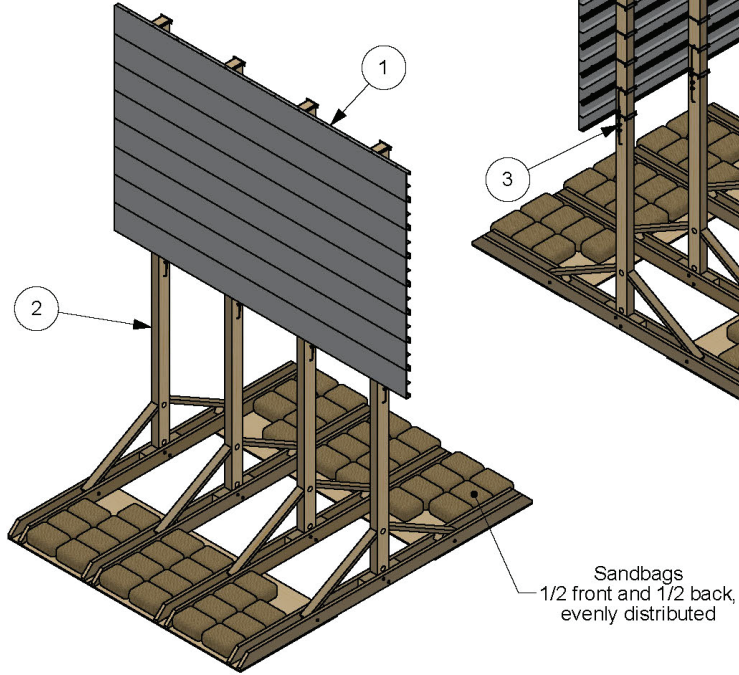

**Figure D8. Vehicle Vertical Accelerometer Trace for Test No. 467824-2 (Accelerometer Located Rear of Center of Gravity).**



Assembly Parts		
#	Part Name	QTY.
1	Panel Assembly	1
2	Frame Assembly	1
3	Cable Assembly	4
4	40lb Sandbag	44
5	Clamp Plate	36
6	Bolt, 3/8 x 6-1/2 hex	72
7	Washer, 3/8 lock	72
8	Nut, 3/8 hex	72

Isometric Views



Detail A  
Scale 1 : 10

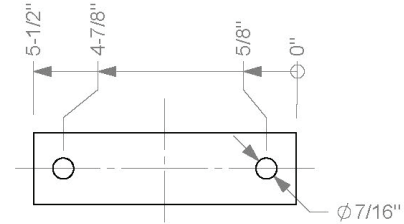

Clamp Plate  
Sheet Steel, 1 1/2" x 11 gauge (1/8")  
Scale 1:3

		Roadside Safety and Physical Security Division Proving Ground -	
Project	467824-4	Large Temporary Sign	
Drawn By	GES	Scale	1:50 Sheet 1 of 7 Isometric Views
Approved:		Date:	
Roger Blyth:			2014-05-21

T:\2013-2014\467824-4\DOT Temp Sign Supp\467824-4\Drafting\467824-4 Drawing

APPENDIX E. DETAILS OF THE TEST ARTICLE FOR TEST NOS. 467824-4 AND 467824-3

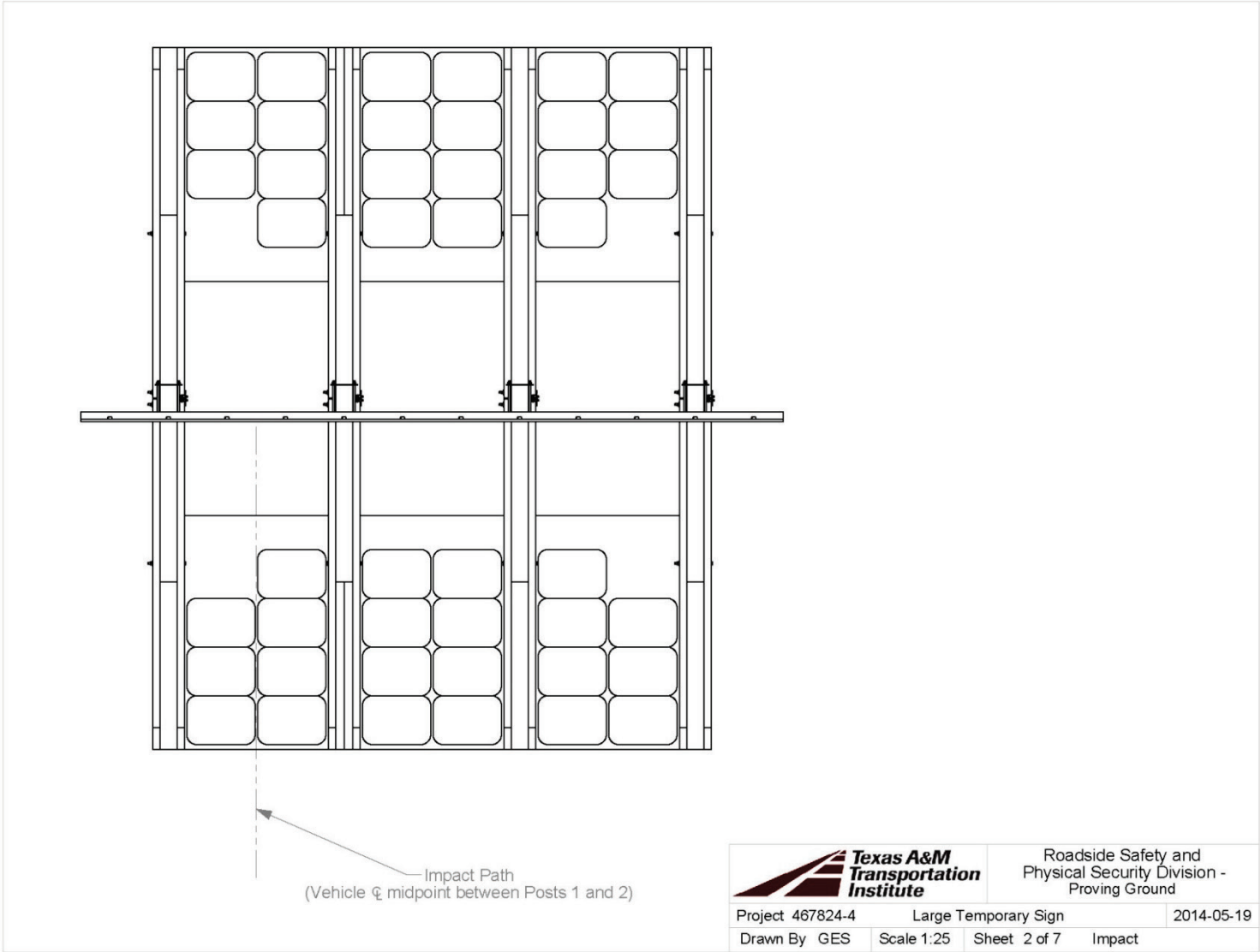

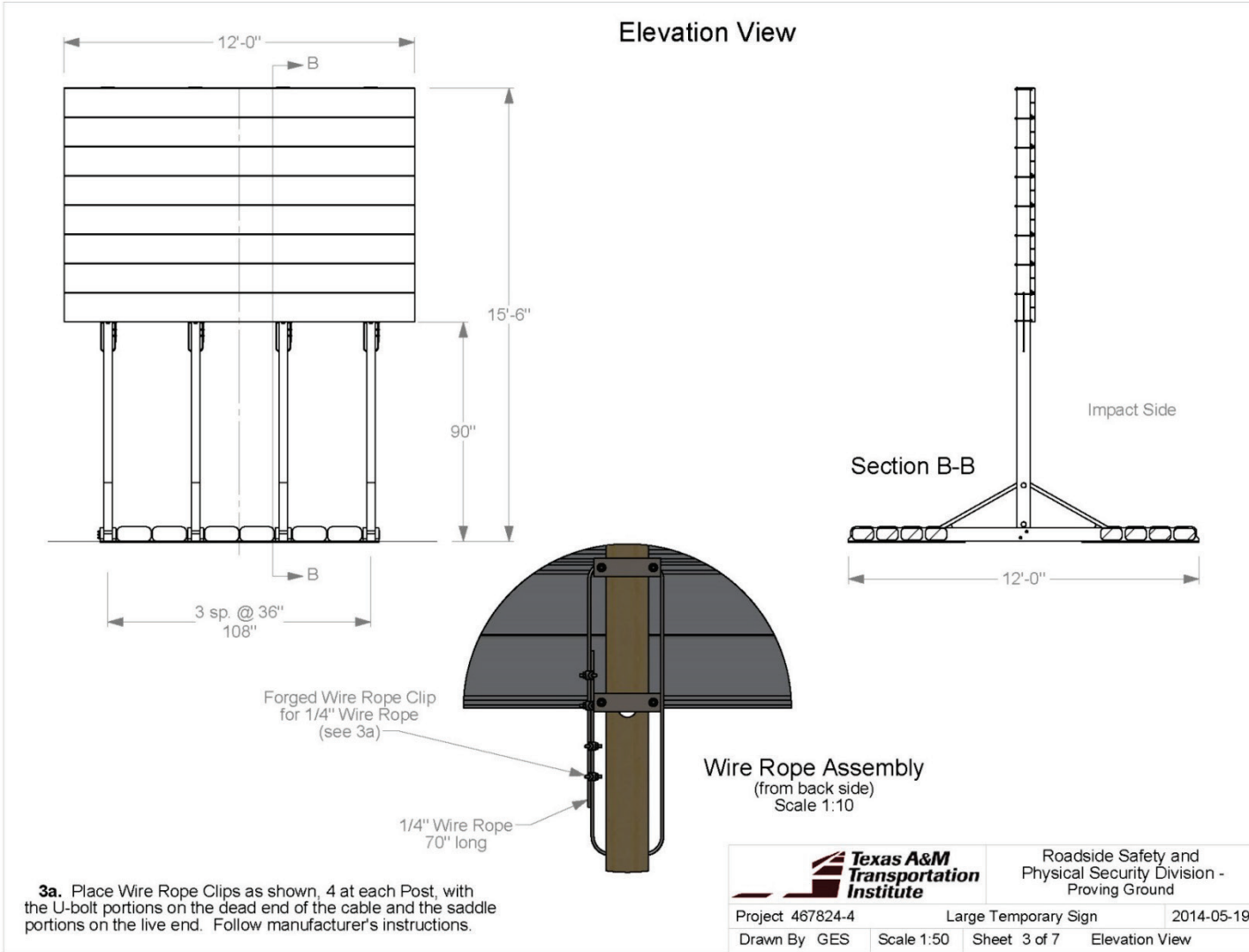

T:\2013-2014\467824 - TxDOT Temp Sign Support\467824-4\Drafting\467824-4 Drawing

**Panel Assembly**

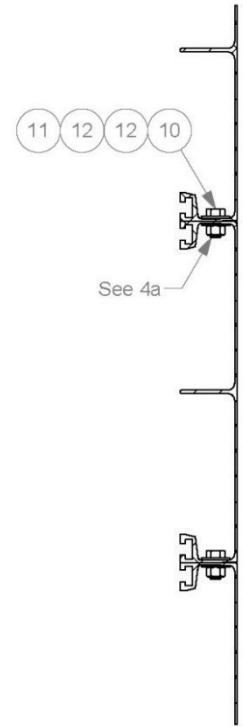
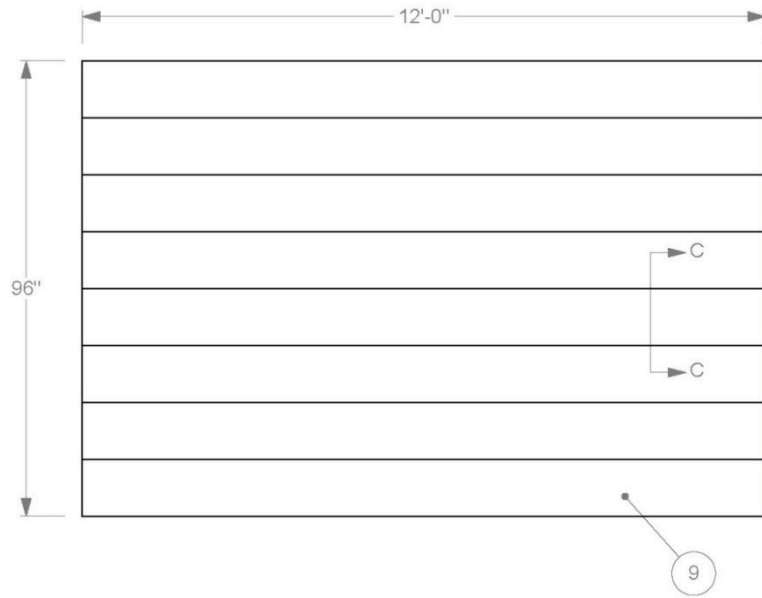

**Section C-C**

Scale 1 : 5

Panel Assembly Parts		
#	Part Name	QTY.
9	Aluminum Sign Panel, 12" x 12'	8
10	Bolt, 3/8 x 3/4 hex	49
11	Nut, 3/8 hex	49
12	Washer, 3/8 flat	98

**4a.** At each joint at each end, and then at maximum  $\phi$  24" spacing.



Roadside Safety and  
Physical Security Division -  
Proving Ground

Project 467824-4	Large Temporary Sign	2014-05-19
Drawn By GES	Scale 1:30	Sheet 4 of 7
Panel Assembly		

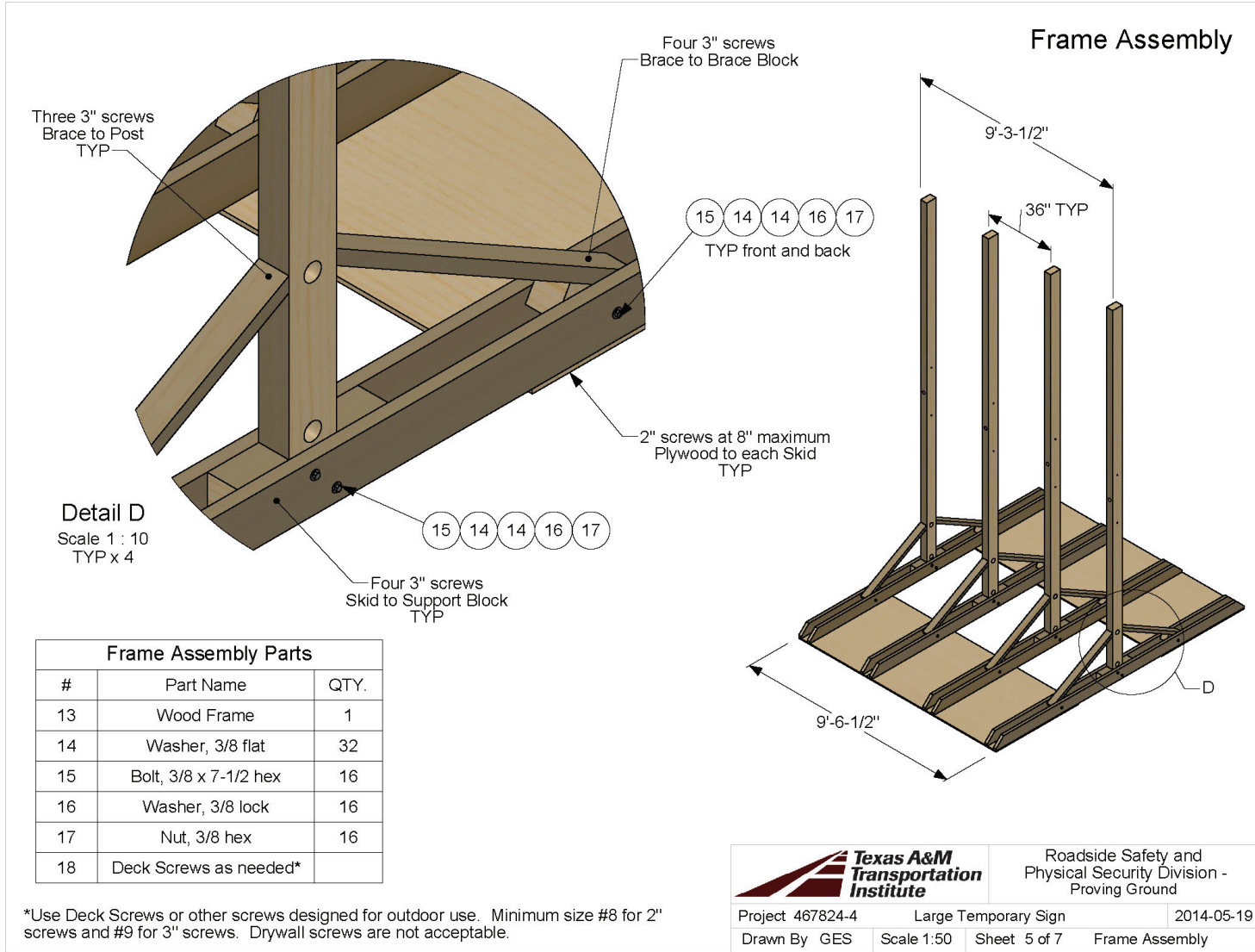

T:\2013-2014\67824 - TxDOT Temp Sign Support\467824-4\Drafting\467824-4 Drawing

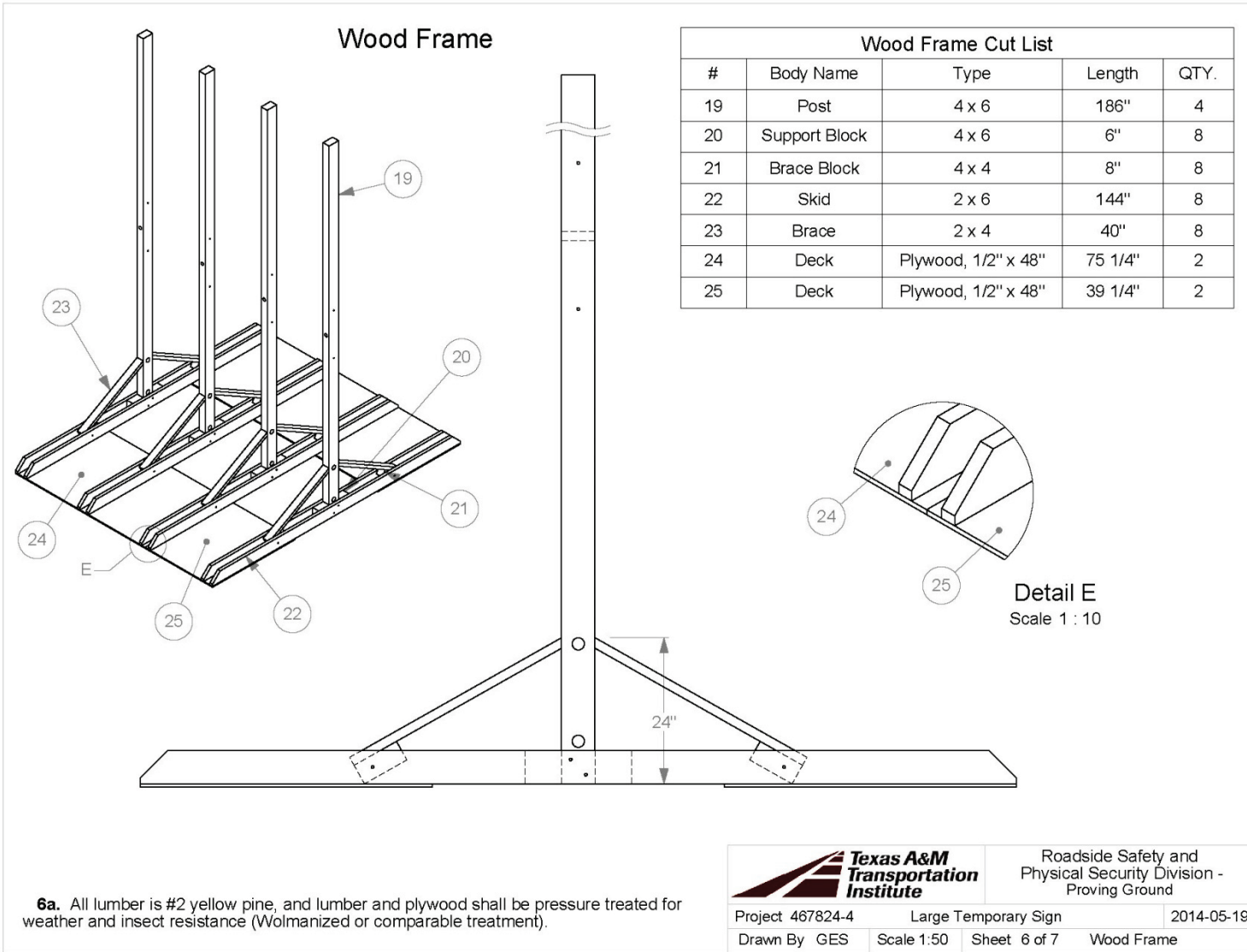

T:\2013-2014\467824 - TxDOT Temp Sign Support\467824-4\Drafting\467824-4 Drawing



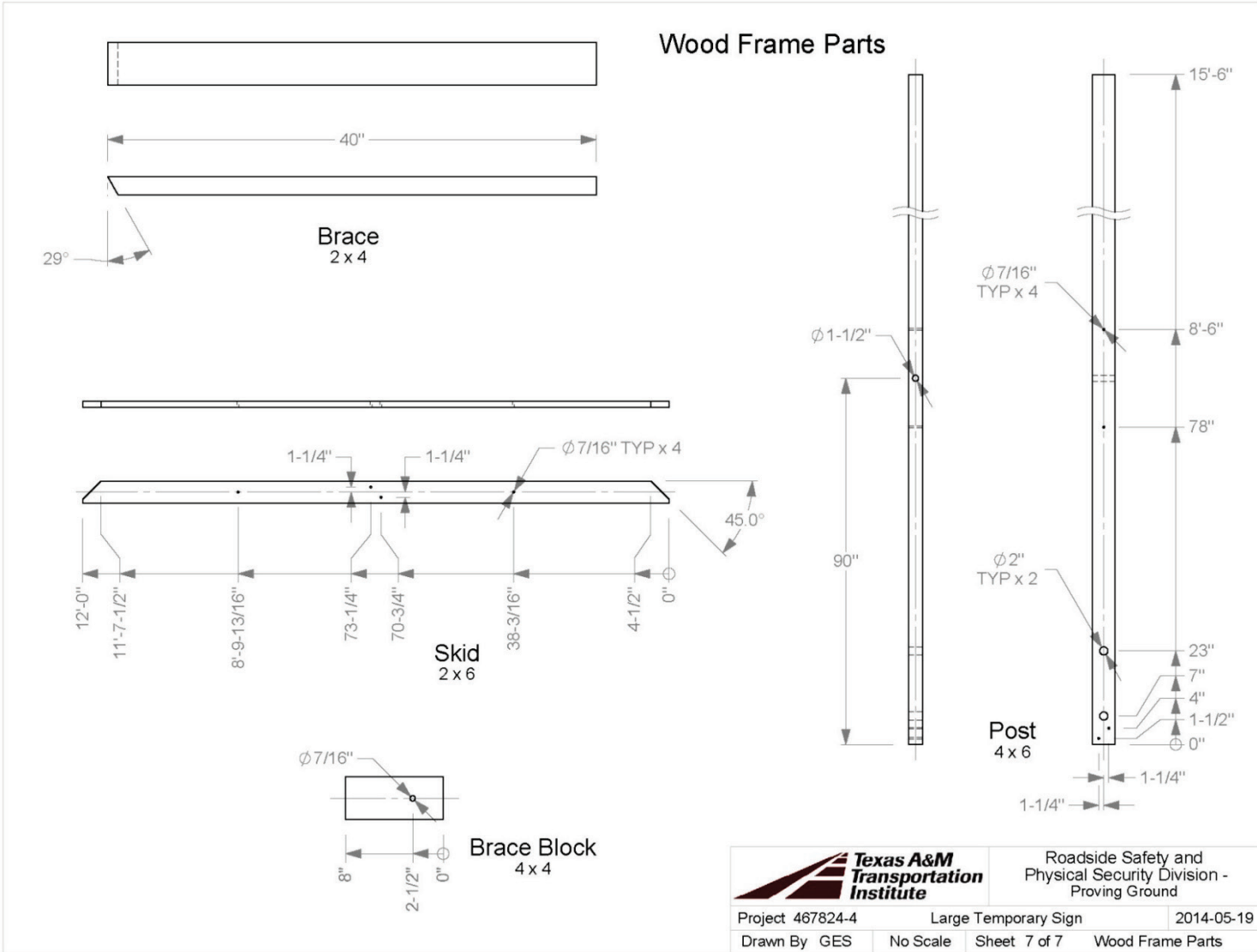

T:\2013-2014\467824 - TxDOT Temp Sign Support\467824-4\Drafting\467824-4 Drawing





**APPENDIX F. CERTIFICATION DOCUMENTATION FOR  
TEST NOS. 467824-4 AND 467824-3**

TEST NUMBER	467824 3-4
TEST NAME	TxDOT Temporary Signs
DATE	2014-05-30

No paperwork is available for the material used for these tests.



# APPENDIX G. CRASH TEST DATA AND INFORMATION FOR TEST NO. 467824-4

## G1. VEHICLE INFORMATION

**Table G1. Vehicle Properties for Test No. 467824-4.**

Date: 2014-05-30 Test No.: 467824-4 VIN No.: KNAD123786319787  
 Year: 2008 Make: Kia Model: Rio  
 Tire Inflation Pressure: 32 psi Odometer: 112475 Tire Size: 185/65R14

Describe any damage to the vehicle prior to test: \_\_\_\_\_

● Denotes accelerometer location.

NOTES: None

Engine Type: 4 cylinder  
 Engine CID: 1.6 liter  
 Transmission Type:  
 Auto or  Manual  
 FWD  RWD  4WD  
 Optional Equipment:  
None

Dummy Data:  
 Type: 50<sup>th</sup> percentile male  
 Mass: 165 lb  
 Seat Position: Driver side

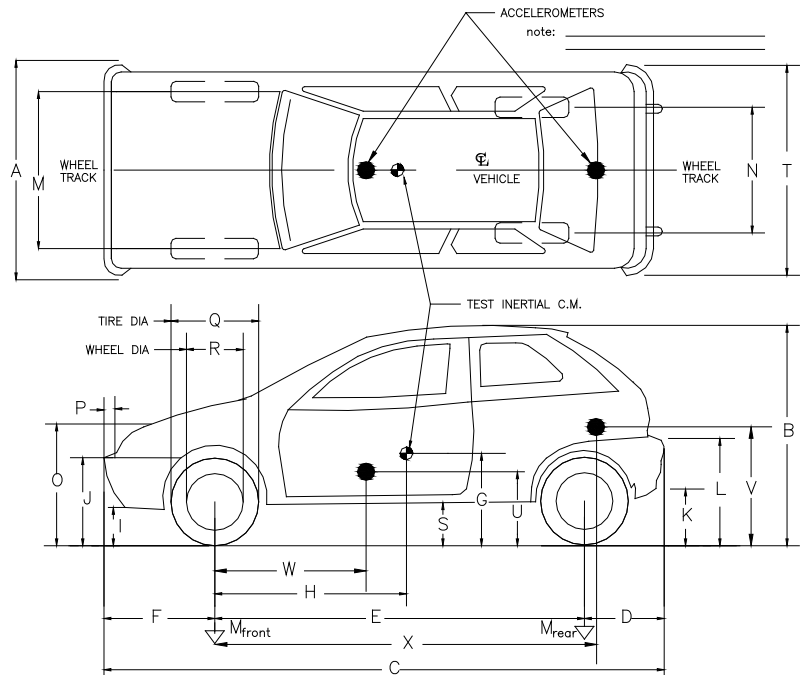

**Geometry:** inches

A	<u>66.38</u>	F	<u>33.00</u>	K	<u>11.75</u>	P	<u>4.12</u>	U	<u>14.50</u>
B	<u>58.25</u>	G	<u>----</u>	L	<u>25.00</u>	Q	<u>22.18</u>	V	<u>21.50</u>
C	<u>165.75</u>	H	<u>35.25</u>	M	<u>57.75</u>	R	<u>15.38</u>	W	<u>44.00</u>
D	<u>34.00</u>	I	<u>8.00</u>	N	<u>57.12</u>	S	<u>9.00</u>	X	<u>108.00</u>
E	<u>98.75</u>	J	<u>21.00</u>	O	<u>31.00</u>	T	<u>66.12</u>		

Wheel Center Ht Front 11.00 Wheel Center Ht Rear 11.00

<b>GVWR Ratings:</b>	<b>Mass: lb</b>	<b>Curb</b>	<b>Test Inertial</b>	<b>Gross Static</b>
Front	<u>1918</u>	$M_{front}$	<u>1607</u>	<u>1650</u>
Back	<u>1874</u>	$M_{rear}$	<u>903</u>	<u>955</u>
Total	<u>3638</u>	$M_{Total}$	<u>2510</u>	<u>2605</u>

**Mass Distribution:**

lb LF: 799 RF: 770 LR: 448 RR: 423

**Table G2. Exterior Crush Measurements for Test No. 467824-4.**

Date: 2014-05-30 Test No.: 467824-4 VIN No.: KNAD123786319787  
 Year: 2008 Make: Kia Model: Rio

**VEHICLE CRUSH MEASUREMENT SHEET<sup>1</sup>**

Complete When Applicable	
End Damage	Side Damage
Undeformed end width _____ Corner shift: A1 _____ A2 _____ End shift at frame (CDC) (check one) < 4 inches _____ ≥ 4 inches _____	Bowing: B1 _____ X1 _____ B2 _____ X2 _____ Bowing constant $\frac{X1 + X2}{2} = \underline{\hspace{2cm}}$

Note: Measure C<sub>1</sub> to C<sub>6</sub> from Driver to Passenger side in Front or Rear impacts – Rear to Front in Side Impacts.

Specific Impact Number	Plane* of C-Measurements	Direct Damage		Field L**	C <sub>1</sub>	C <sub>2</sub>	C <sub>3</sub>	C <sub>4</sub>	C <sub>5</sub>	C <sub>6</sub>	±D
		Width** (CDC)	Max*** Crush								
1	Front plane at bumper ht	----	0	----	----	----	----	----	----	----	----
	Measurements recorded										
	<b>in inches</b>										

<sup>1</sup>Table taken from National Accident Sampling System (NASS).

\*Identify the plane at which the C-measurements are taken (e.g., at bumper, above bumper, at sill, above sill, at beltline, etc.) or label adjustments (e.g., free space).

Free space value is defined as the distance between the baseline and the original body contour taken at the individual C locations. This may include the following: bumper lead, bumper taper, side protrusion, side taper, etc. Record the value for each C-measurement and maximum crush.

\*\*Measure and document on the vehicle diagram the beginning or end of the direct damage width and field L (e.g., side damage with respect to undamaged axle).

\*\*\*Measure and document on the vehicle diagram the location of the maximum crush.

Note: Use as many lines/columns as necessary to describe each damage profile.

**Table G3. Occupant Compartment Measurements for Test No. 467824-4.**

Date: 2014-05-30 Test No.: 467824-4 VIN No.: KNADE123786319787  
 Year: 2008 Make: Kia Model: Rio

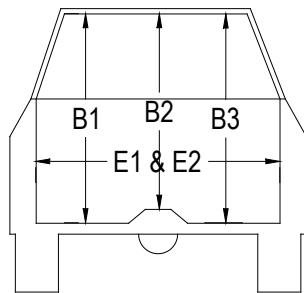
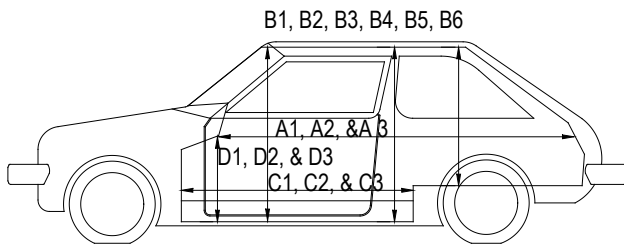
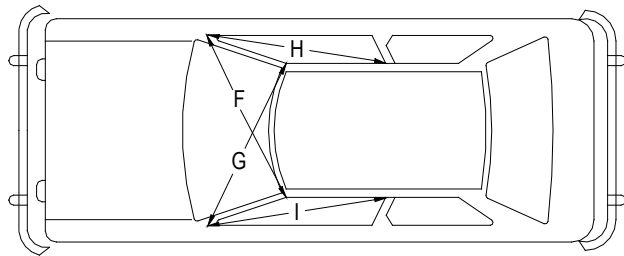

**OCCUPANT COMPARTMENT DEFORMATION MEASUREMENT**

	<b>Before</b> ( inches )	<b>After</b> ( inches )
A1	68.00	68.00
A2	67.50	67.50
A3	68.00	68.00
B1	40.50	40.50
B2	36.25	36.25
B3	40.50	40.50
B4	36.25	36.25
B5	32.50	32.50
B6	36.25	36.25
C1	28.00	28.00
C2	----	----
C3	26.75	26.75
D1	9.75	9.75
D2	----	----
D3	9.50	9.50
E1	51.50	51.50
E2	51.25	51.25
F	50.25	50.25
G	50.25	50.25
H	38.00	38.00
I	38.00	38.00
J*	51.00	51.00

\*Lateral area across the cab from driver's side kickpanel to passenger's side kickpanel.

## G2. SEQUENTIAL PHOTOGRAPHS



0.000 s



0.042 s



0.084 s



0.126 s

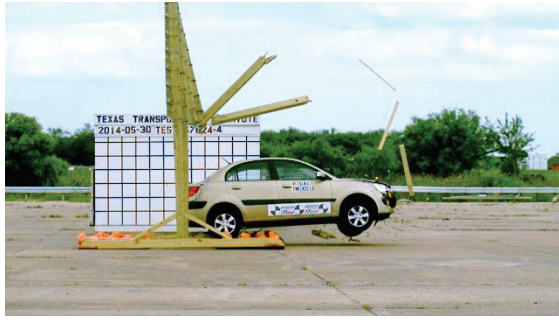
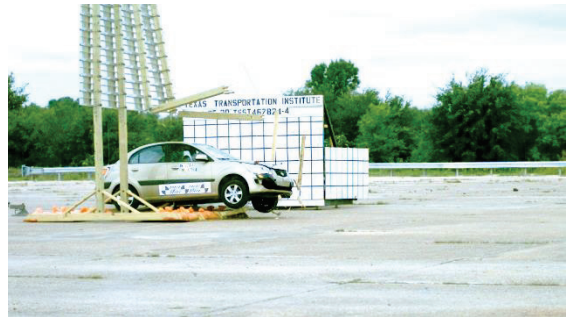

**Figure G1. Sequential Photographs for Test No. 467824-4 (Perpendicular and Oblique Views).**





0.168s



0.210 s

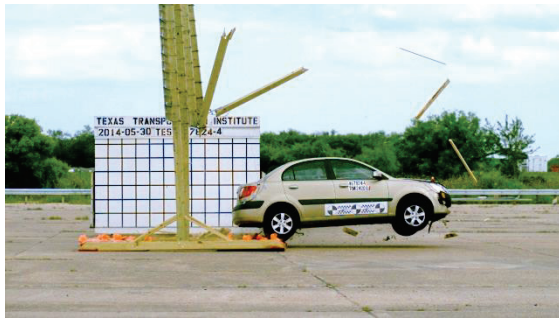
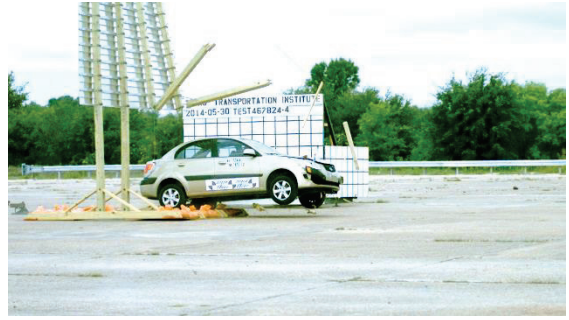

0.252 s

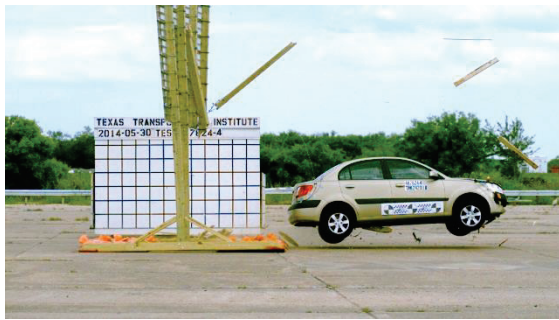

0.294 s



**Figure G1. Sequential Photographs for Test No. 467824-4 (Perpendicular and Oblique Views) (Continued).**

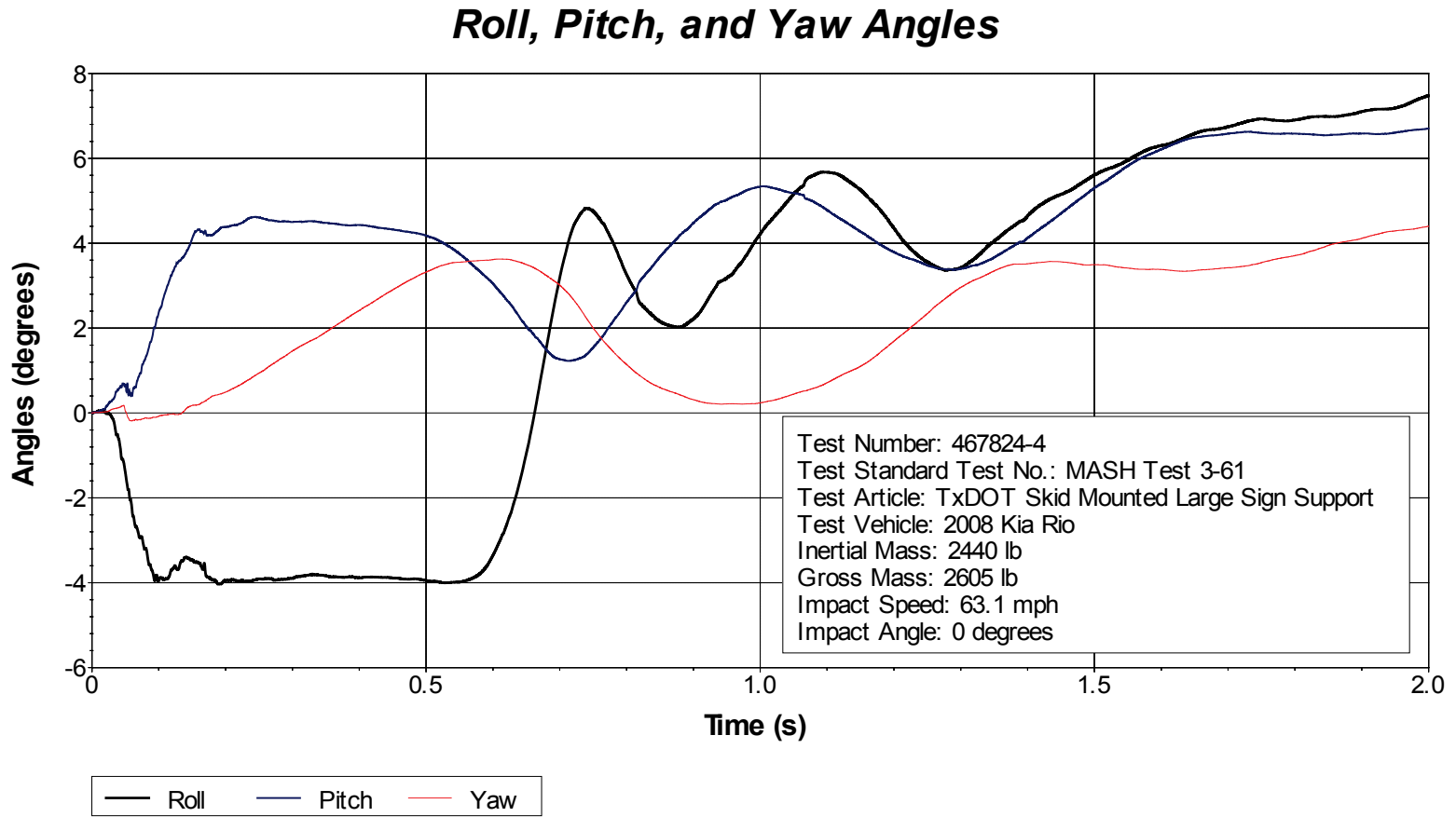

Axes are vehicle-fixed.  
Sequence for determining orientation:

1. Yaw.
2. Pitch.
3. Roll.

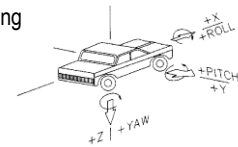
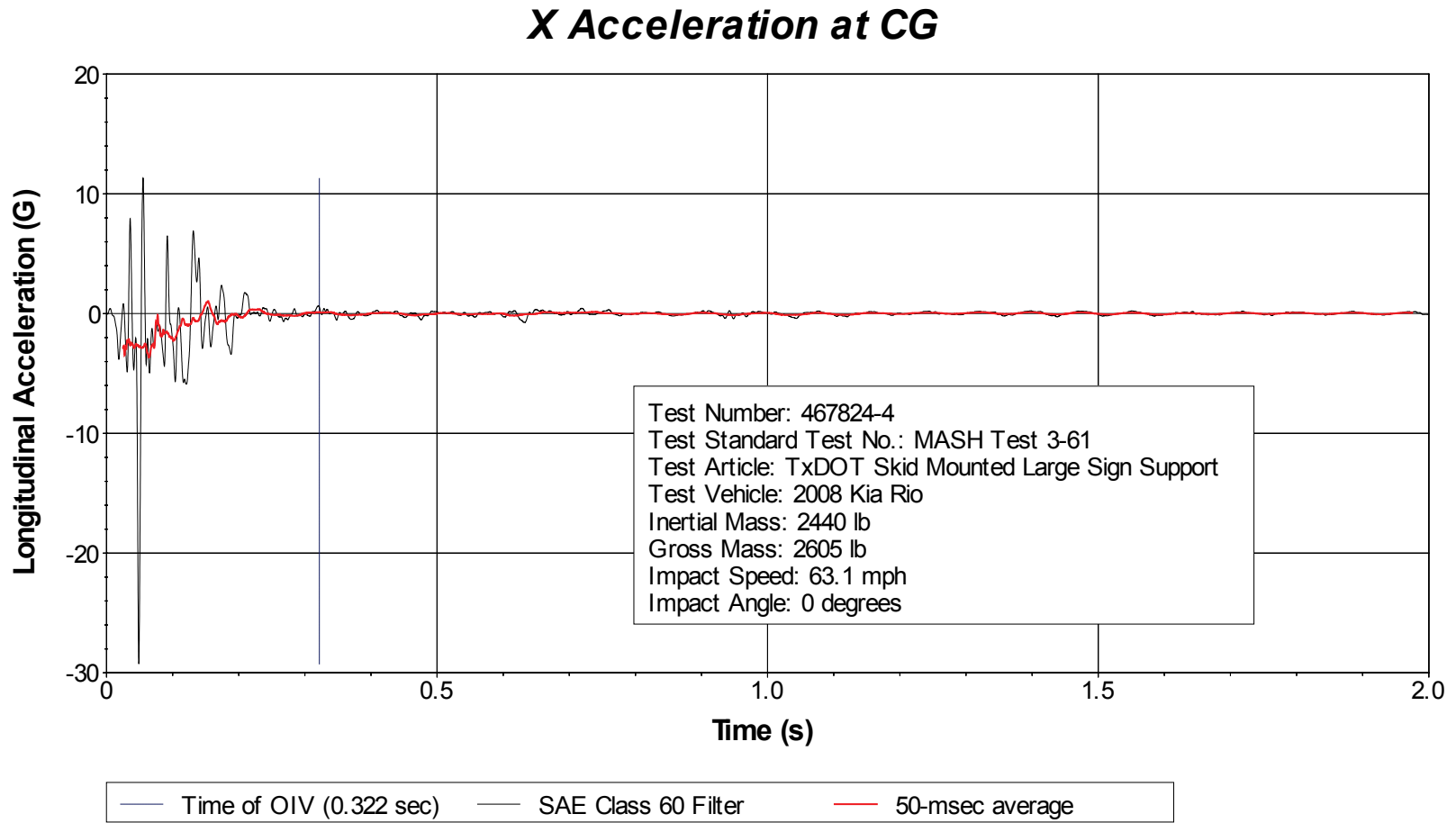
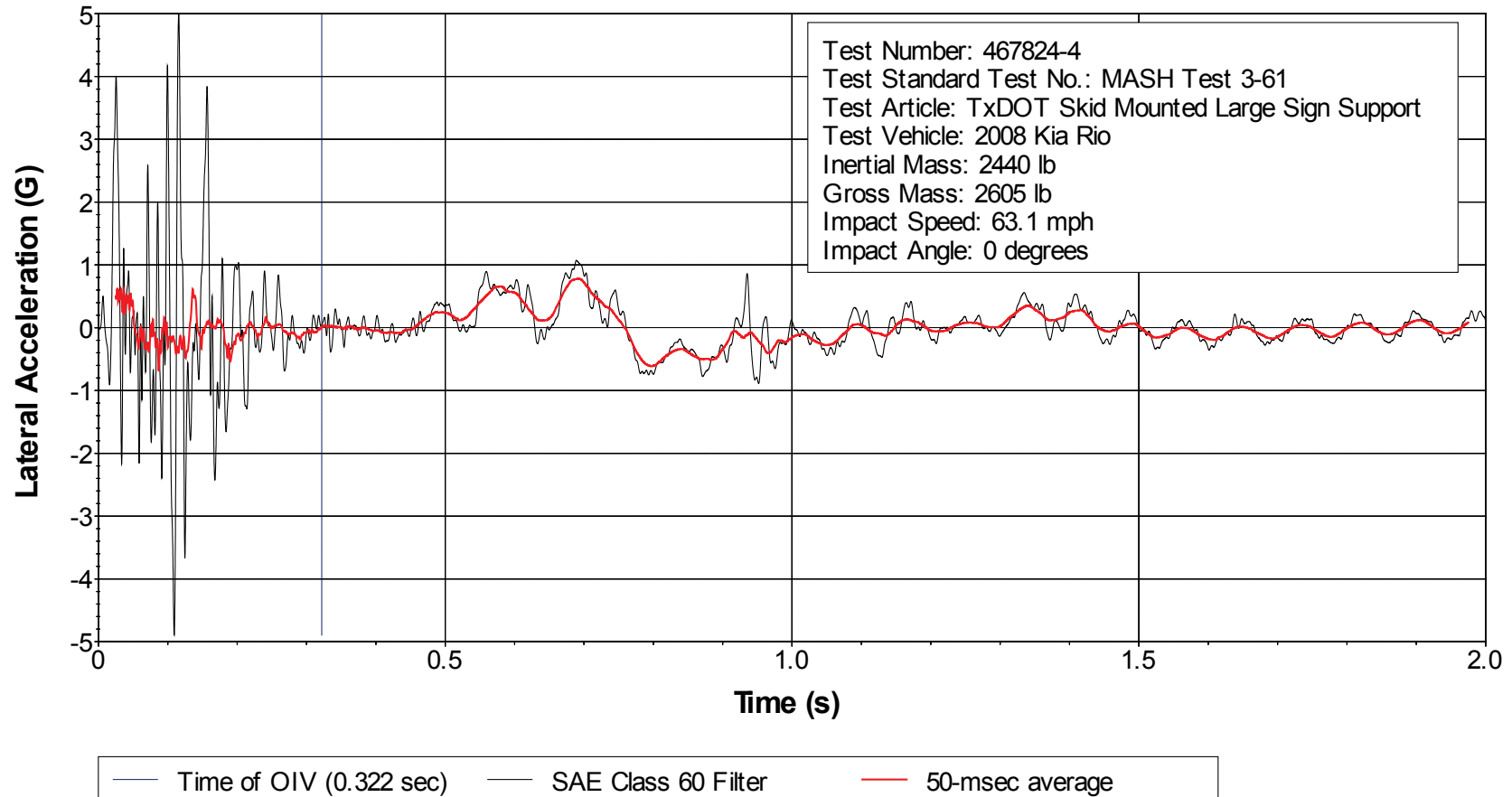

Figure G2. Vehicle Angular Displacements for Test No. 467824-4.



**Figure G3. Vehicle Longitudinal Accelerometer Trace for Test No. 467824-4  
(Accelerometer Located at Center of Gravity).**

### Y Acceleration at CG



**Figure G4. Vehicle Lateral Accelerometer Trace for Test No. 467824-4 (Accelerometer Located at Center of Gravity).**

### Z Acceleration at CG

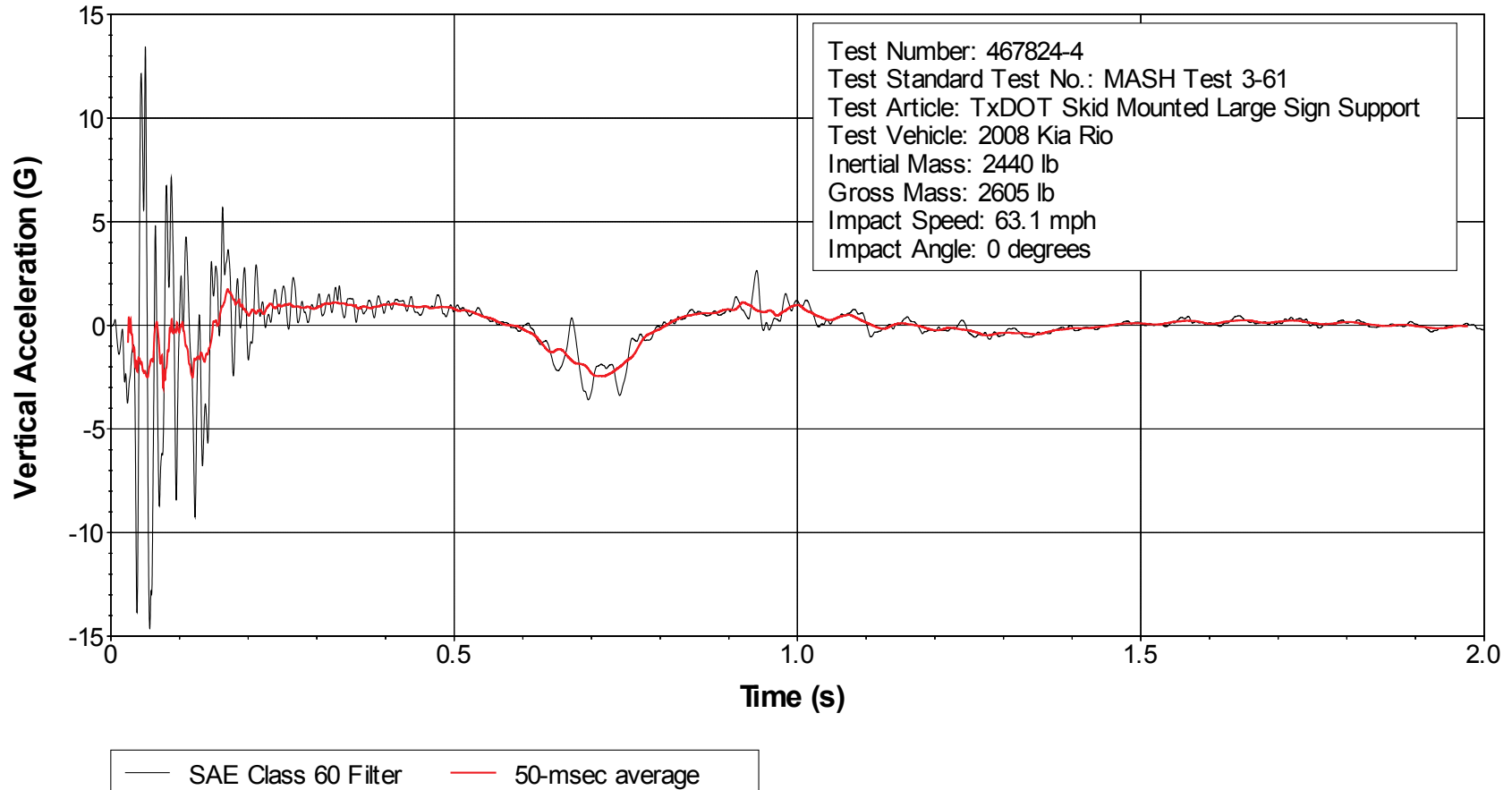

**Figure G5. Vehicle Vertical Accelerometer Trace for Test No. 467824-4 (Accelerometer Located at Center of Gravity).**

### X Acceleration Rear of CG

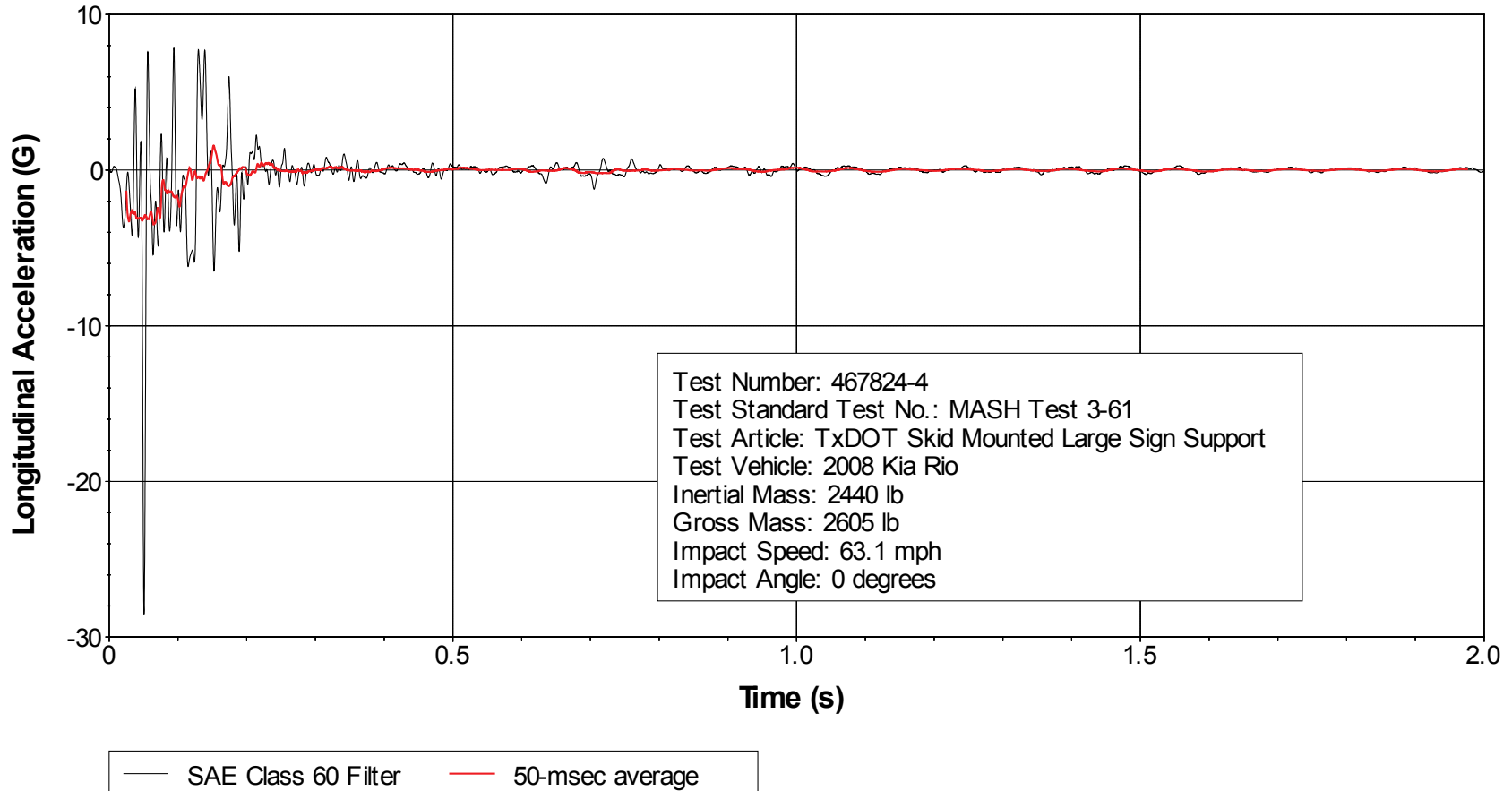

**Figure G6. Vehicle Longitudinal Accelerometer Trace for Test No. 467824-4 (Accelerometer Located Rear of Center of Gravity).**

### Y Acceleration Rear of CG

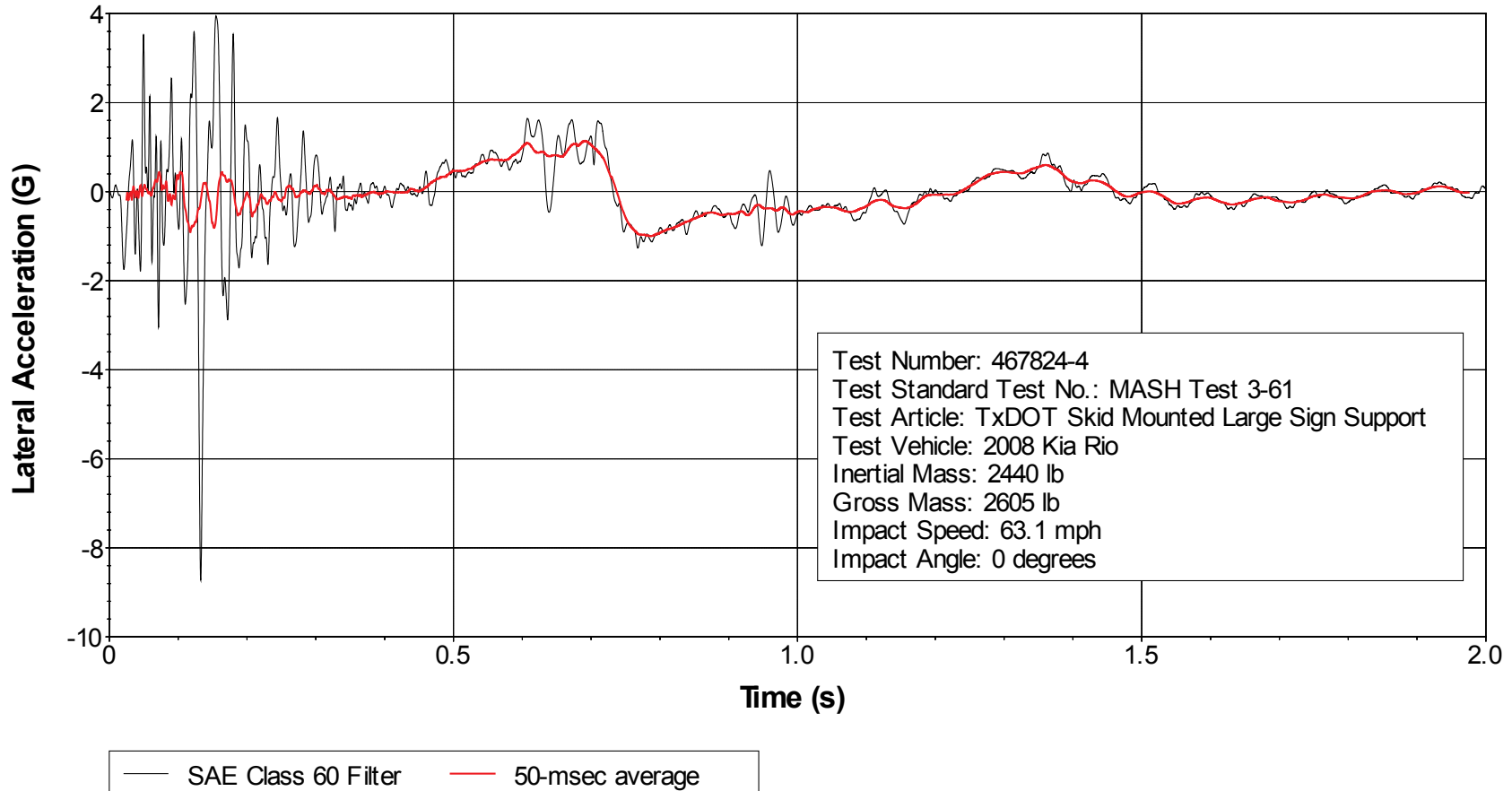

**Figure G7. Vehicle Lateral Accelerometer Trace for Test No. 467824-4 (Accelerometer Located Rear of Center of Gravity).**



### Z Acceleration Rear of CG

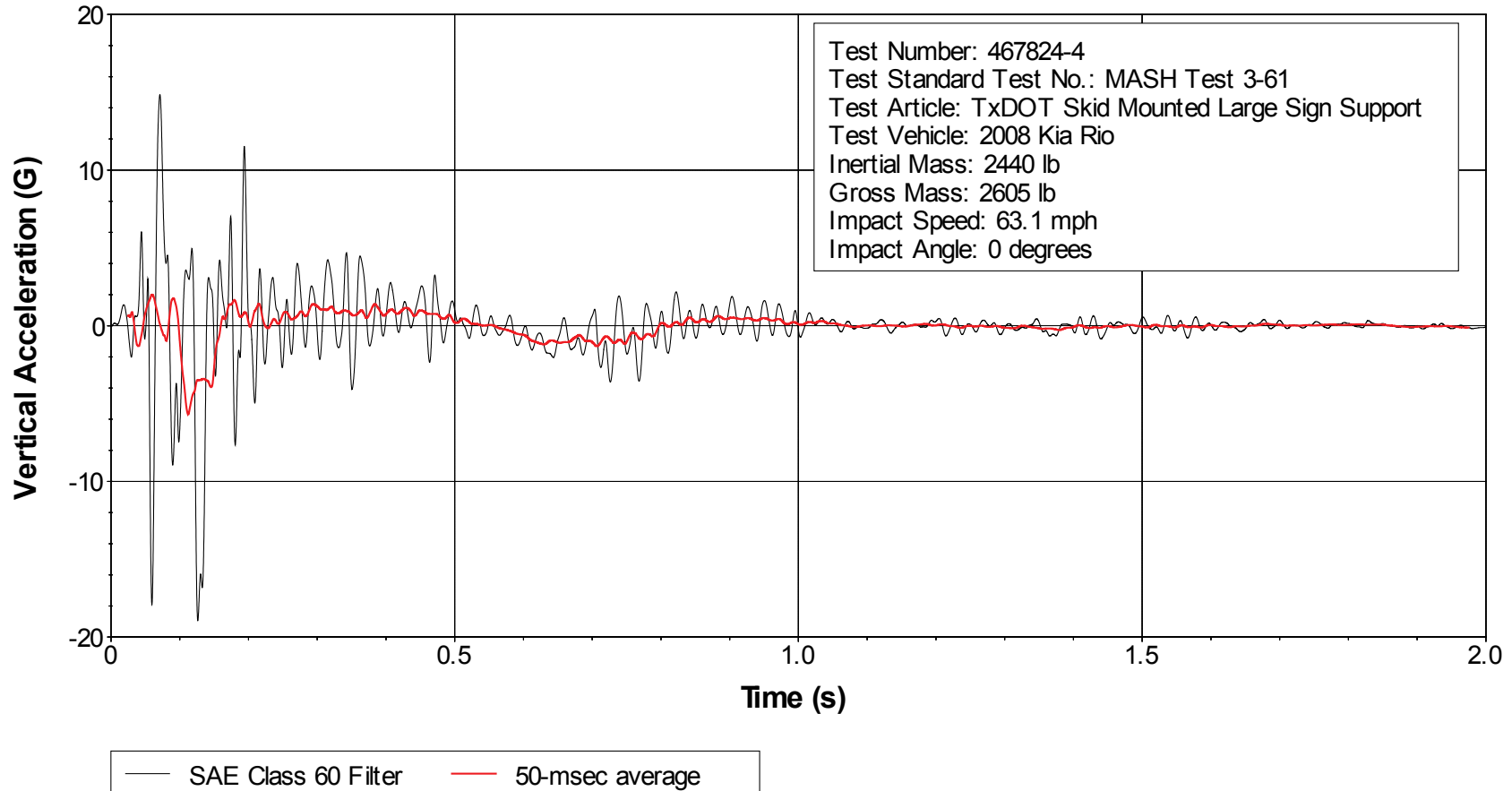

**Figure G8. Vehicle Vertical Accelerometer Trace for Test No. 467824-4 (Accelerometer Located Rear of Center of Gravity).**

# APPENDIX H. CRASH TEST DATA AND INFORMATION FOR TEST NO. 467824-3

## H1. VEHICLE INFORMATION

**Table H1. Vehicle Properties for Test No. 467824-3.**

Date: 2014-05-30      Test No.: 467824-3      VIN No.: 1D7HA182985612053  
 Year: 2008      Make: Dodge      Model: Ram 1500  
 Tire Size: 265/70R17      Tire Inflation Pressure: 35 psi  
 Tread Type: Highway      Odometer: 170326  
 Note any damage to the vehicle prior to test: None

● Denotes accelerometer location.

NOTES: None

Engine Type: V-8  
 Engine CID: 5.7 liter

Transmission Type:  
 Auto      or       Manual  
 FWD     RWD     4WD

Optional Equipment:  
None

Dummy Data:  
 Type: None  
 Mass: NA  
 Seat Position: NA

**Geometry:** inches

A	<u>78.25</u>	F	<u>36.00</u>	K	<u>29.00</u>	P	<u>2.88</u>	U	<u>28.50</u>
B	<u>74.00</u>	G	<u>28.50</u>	L	<u>20.00</u>	Q	<u>30.50</u>	V	<u>30.50</u>
C	<u>223.75</u>	H	<u>61.09</u>	M	<u>68.50</u>	R	<u>18.38</u>	W	<u>61.10</u>
D	<u>47.25</u>	I	<u>16.00</u>	N	<u>68.00</u>	S	<u>14.25</u>	X	<u>77.10</u>
E	<u>140.50</u>	J	<u>27.75</u>	O	<u>46.50</u>	T	<u>77.00</u>		
	Wheel Center Height Front	<u>14.75</u>		Wheel Well Clearance (Front)	<u>5.50</u>		Bottom Frame Height - Front	<u>18.75</u>	
	Wheel Center Height Rear	<u>14.75</u>		Wheel Well Clearance (Rear)	<u>10.50</u>		Bottom Frame Height - Rear	<u>24.50</u>	

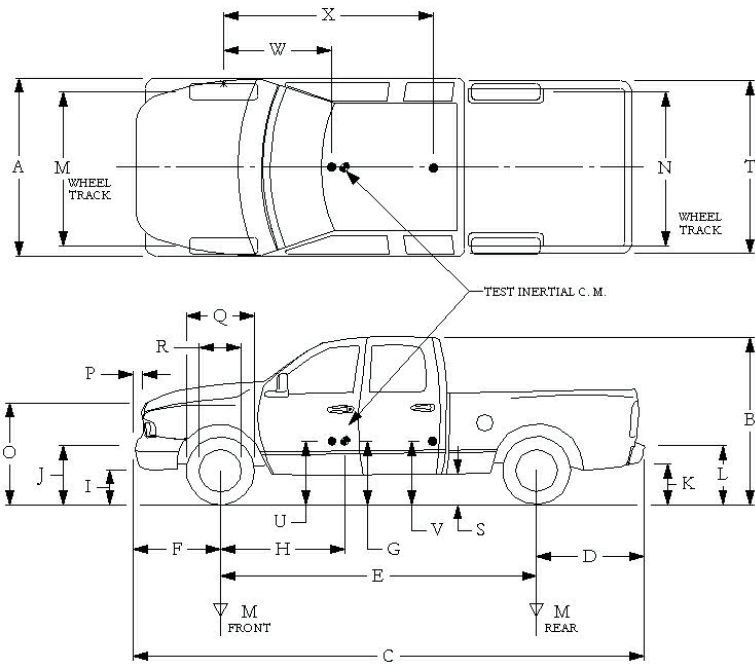

GVWR Ratings:		Mass: lb	Curb	Test Inertial	Gross Static
Front	<u>3700</u>	$M_{front}$	<u>2885</u>	<u>2835</u>	----
Back	<u>3900</u>	$M_{rear}$	<u>2041</u>	<u>2181</u>	----
Total	<u>6700</u>	$M_{Total}$	<u>4926</u>	<u>5016</u>	----

**Mass Distribution:**

lb      LF: 1434      RF: 1401      LR: 1063      RR: 1118

**Table H2. Vehicle Parametric Measurements for Vehicle CG.**

Date: 2014-05-30 Test No.: 467824-3 VIN: 1D7HA182985612053  
 Year: 2008 Make: Dodge Model: Ram 1500  
 Body Style: Quad Cab Mileage: 170326  
 Engine: V-8 5.7 liter Transmission: Automatic  
 Fuel Level: Empty Ballast: 176 lb (440 lb max)  
 Tire Pressure: Front: 35 psi Rear: 35 psi Size: 265/70R17

<b>Measured Vehicle Weights:</b> (lb)			
LF:	<u>1434</u>	RF:	<u>1401</u>
Front Axle:		<u>2835</u>	
LR:	<u>1063</u>	RR:	<u>1118</u>
Rear Axle:		<u>2181</u>	
Left:	<u>2497</u>	Right:	<u>2519</u>
Total:		<u>5016</u>	
5000 ±110 lb allow ed			
Wheel Base:	<u>140.5</u> inches	Track: F:	<u>68.5</u> inches
148 ±12 inches allow ed		R:	<u>68</u> inches
		Track = (F+R)/2 = 67 ±1.5 inches allow ed	
<b>Center of Gravity, SAE J874 Suspension Method</b>			
X:	<u>61.09</u> in	Rear of Front Axle	(63 ±4 inches allow ed)
Y:	<u>0.15</u> in	Left - Right +	of Vehicle Centerline
Z:	<u>28.5</u> in	Above Ground	(minumum 28.0 inches allow ed)

Hood Height: 46.50 inches Front Bumper Height: 27.75 inches  
 43 ±4 inches allowed

Front Overhang: 36.00 inches Rear Bumper Height: 20.00 inches  
 39 ±3 inches allowed

Overall Length: 223.75 inches  
 237 ±13 inches allowed



**Table H4. Occupant Compartment Measurements for Test No. 467824-3.**

Date: 2014-05-30 Test No.: 467824-3 VIN No.: 1D7HA182985612053  
 Year: 2008 Make: Dodge Model: Ram 1500

**OCCUPANT COMPARTMENT  
DEFORMATION MEASUREMENT**

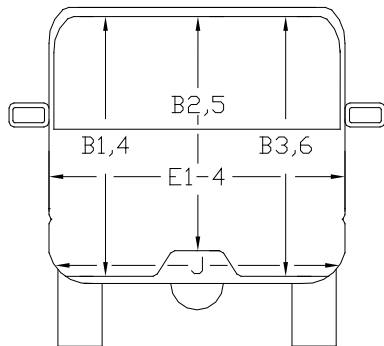
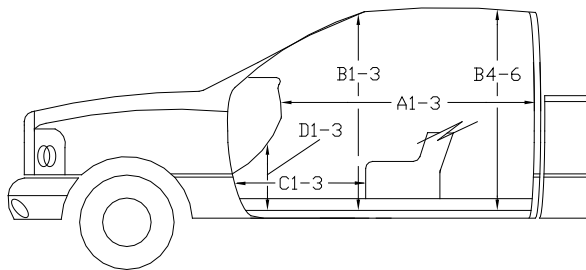
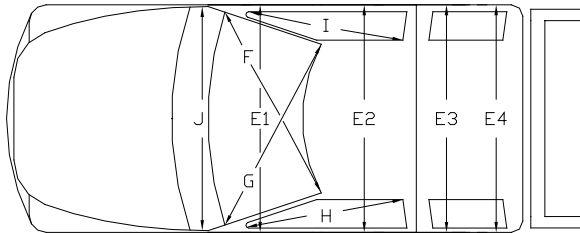

	<b>Before</b> ( inches )	<b>After</b> ( inches )
A1	64.25	64.25
A2	64.75	64.75
A3	65.00	65.00
B1	45.50	45.50
B2	37.75	37.75
B3	45.50	45.50
B4	42.12	42.12
B5	42.75	42.75
B6	42.12	42.12
C1	30.00	30.00
C2	-----	-----
C3	27.75	27.75
D1	12.75	12.75
D2	-----	-----
D3	11.75	11.75
E1	62.75	62.75
E2	64.50	64.50
E3	64.00	64.00
E4	64.50	64.50
F	59.00	59.00
G	59.00	59.00
H	39.00	39.00
I	39.00	39.00
J*	62.25	62.25

\*Lateral area across the cab from driver's side kickpanel to passenger's side kickpanel.

## H2. SEQUENTIAL PHOTOGRAPHS



0.000 s

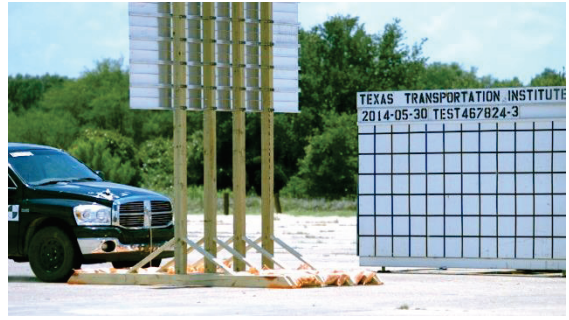

0.050 s

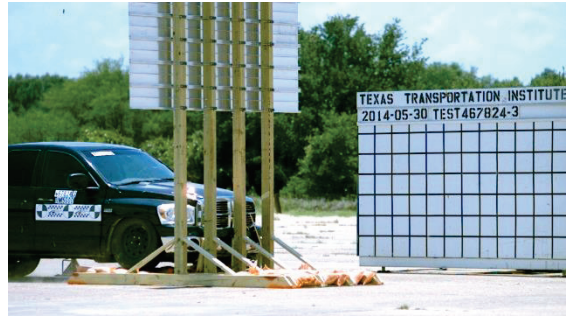

0.100 s

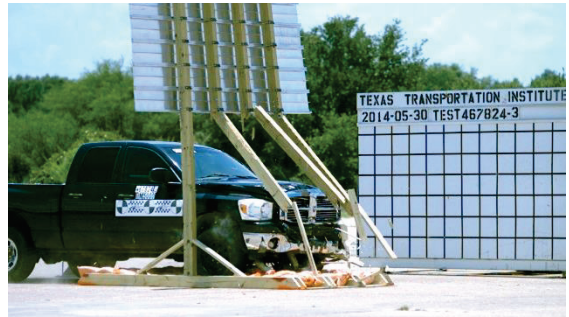

0.150 s

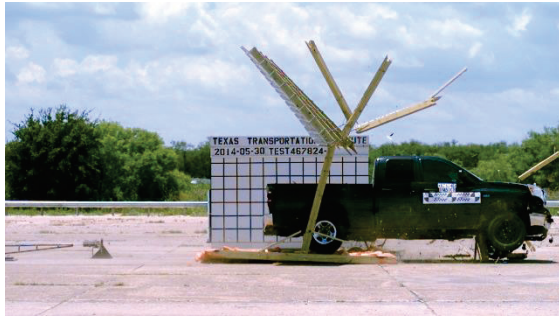

**Figure H1. Sequential Photographs for Test No. 467824-3 (Perpendicular and Oblique Views).**





0.200s



0.250 s



0.300 s

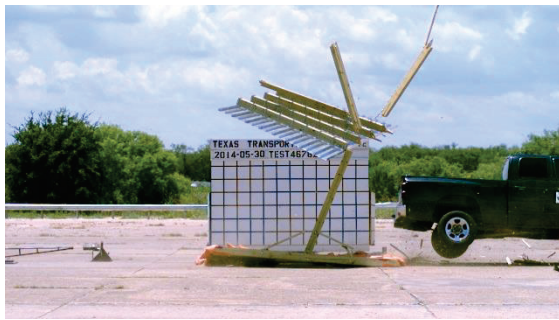

0.350 s

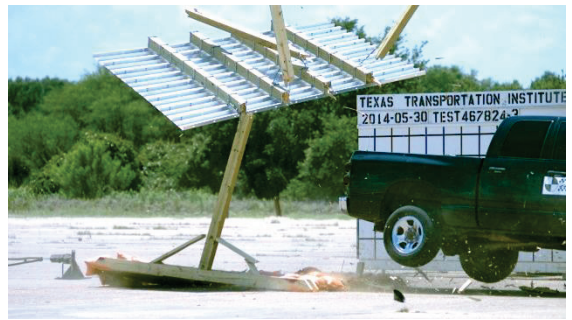

**Figure H1. Sequential Photographs for Test No. 467824-3 (Perpendicular and Oblique Views) (Continued).**



**Roll, Pitch, and Yaw Angles**

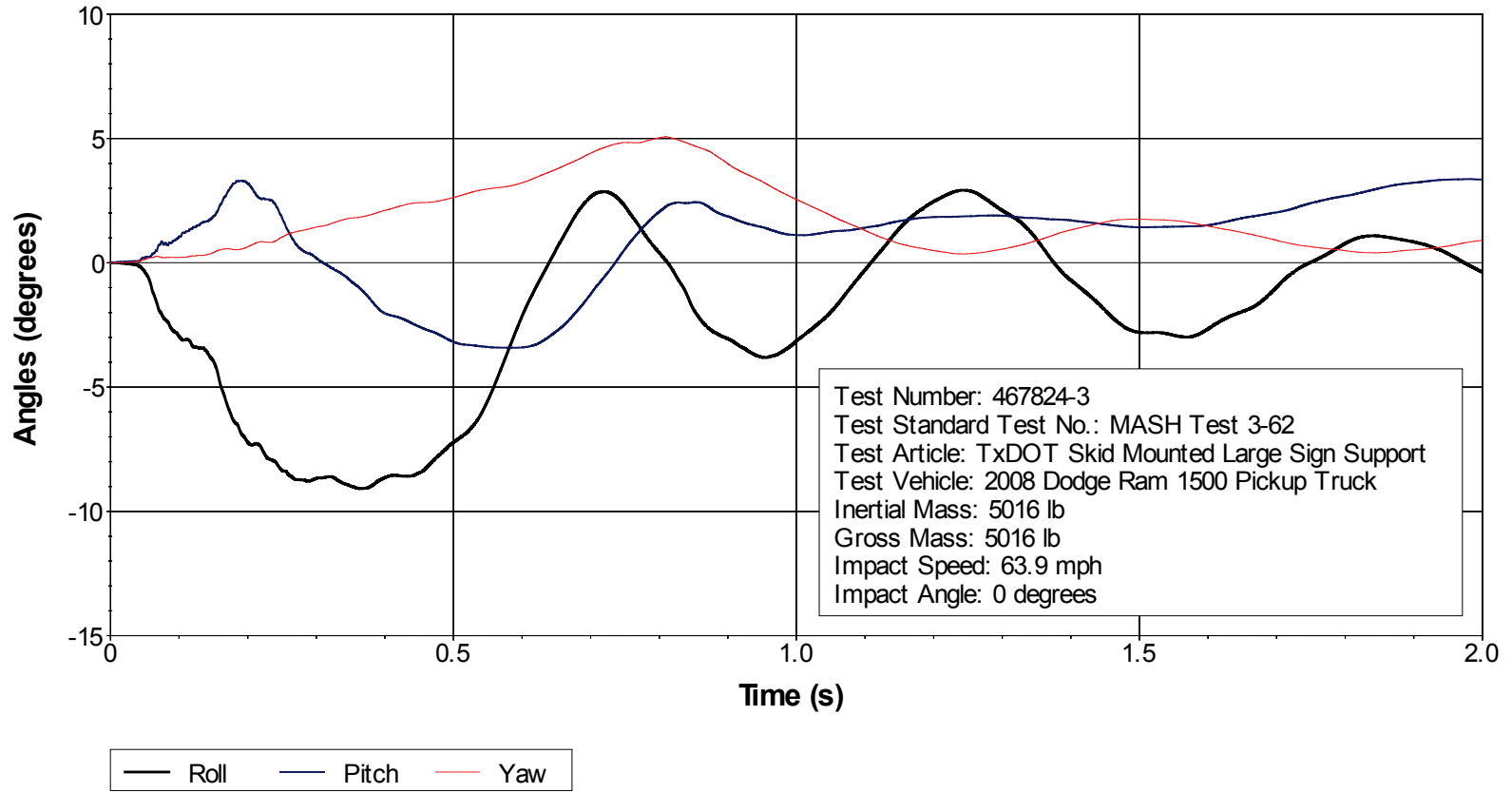

Axes are vehicle-fixed.  
 Sequence for determining orientation:

1. Yaw.
2. Pitch.
3. Roll.

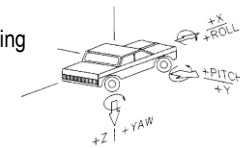

**Figure H2. Vehicle Angular Displacements for Test No. 467824-3.**

### X Acceleration at CG

### H4. VEHICLE ACCELERATIONS

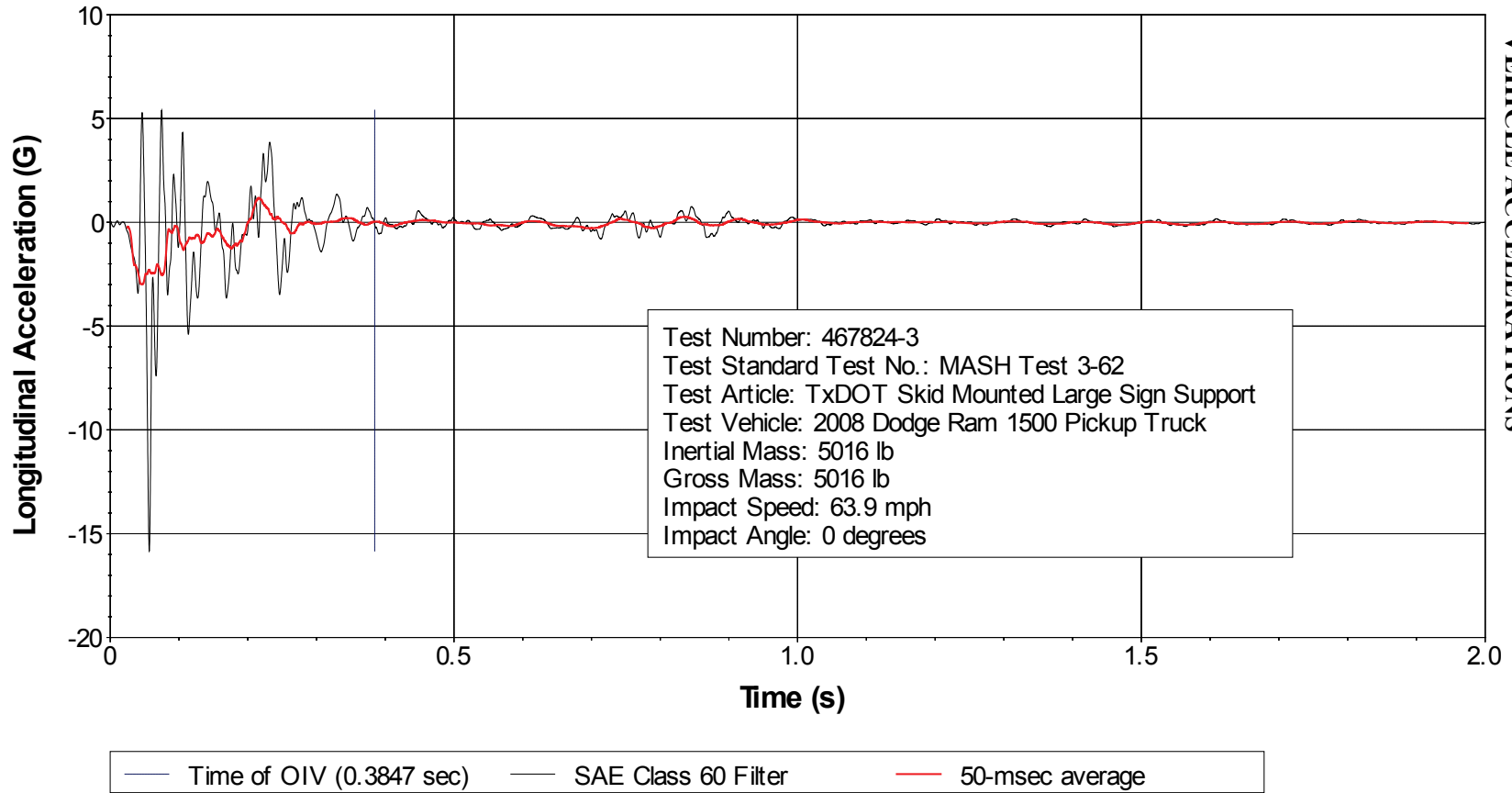

**Figure H3. Vehicle Longitudinal Accelerometer Trace for Test No. 467824-3 (Accelerometer Located at Center of Gravity).**

### Y Acceleration at CG

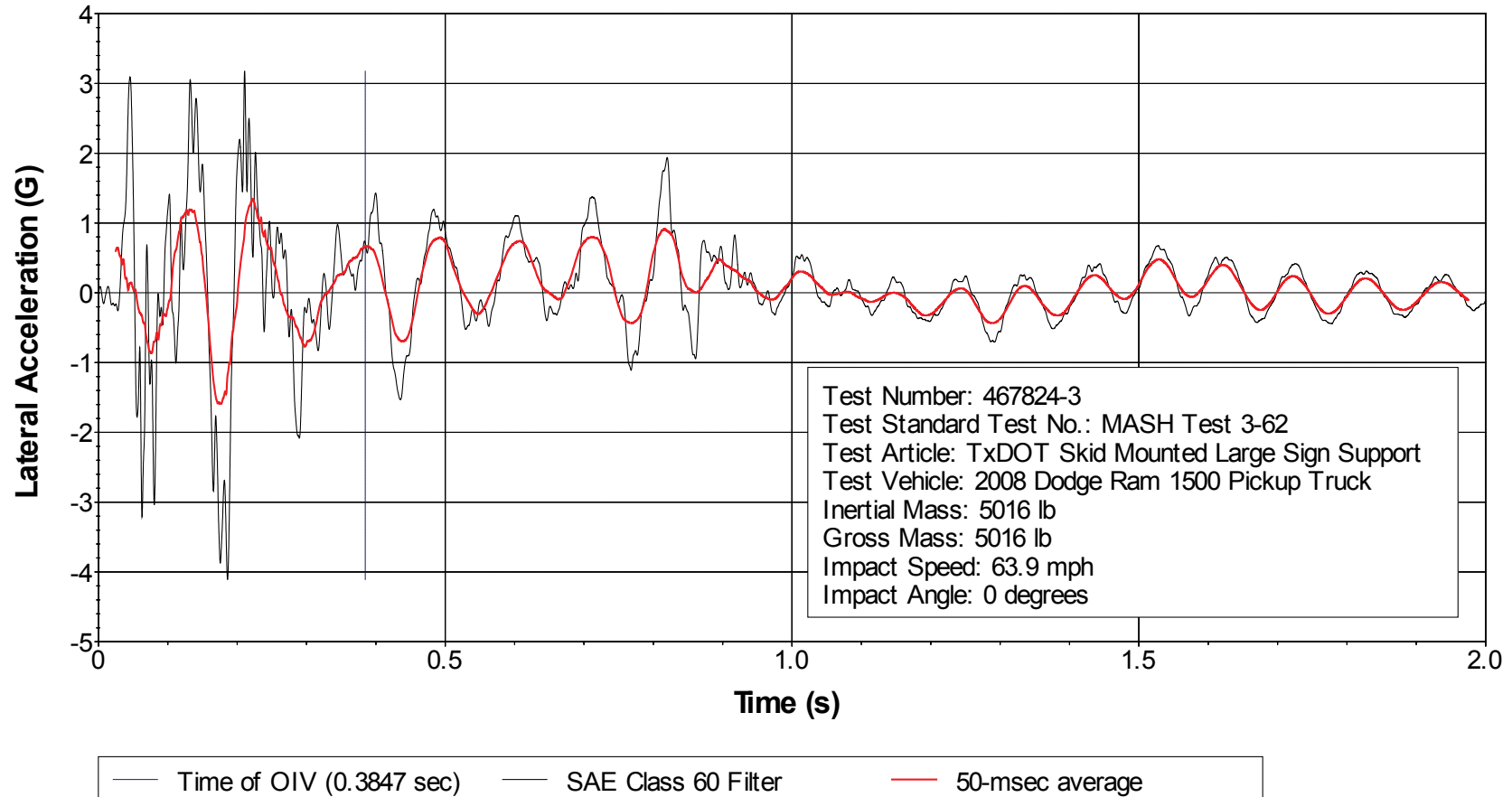

**Figure H4. Vehicle Lateral Accelerometer Trace for Test No. 467824-3 (Accelerometer Located at Center of Gravity).**

### Z Acceleration at CG

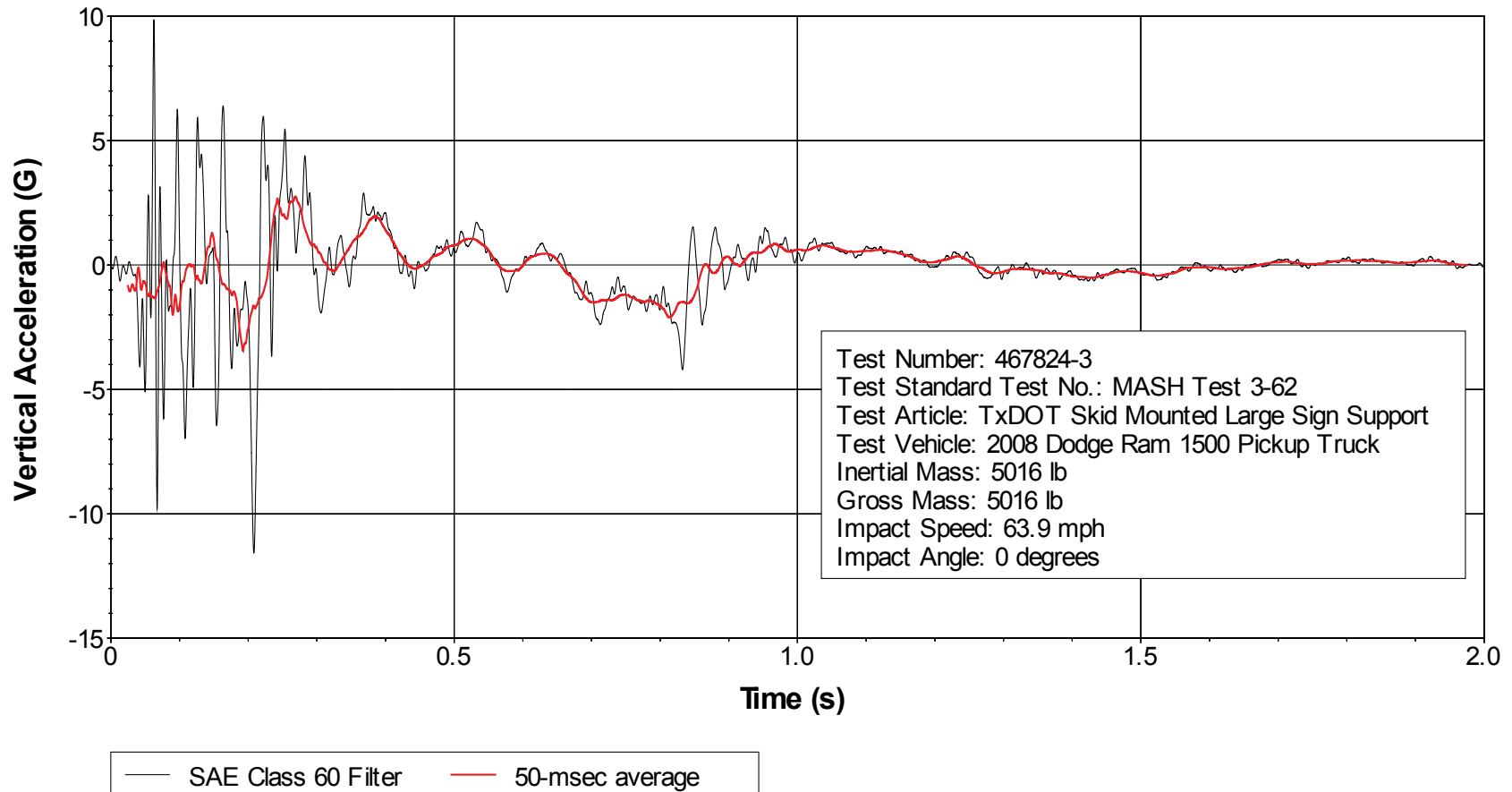
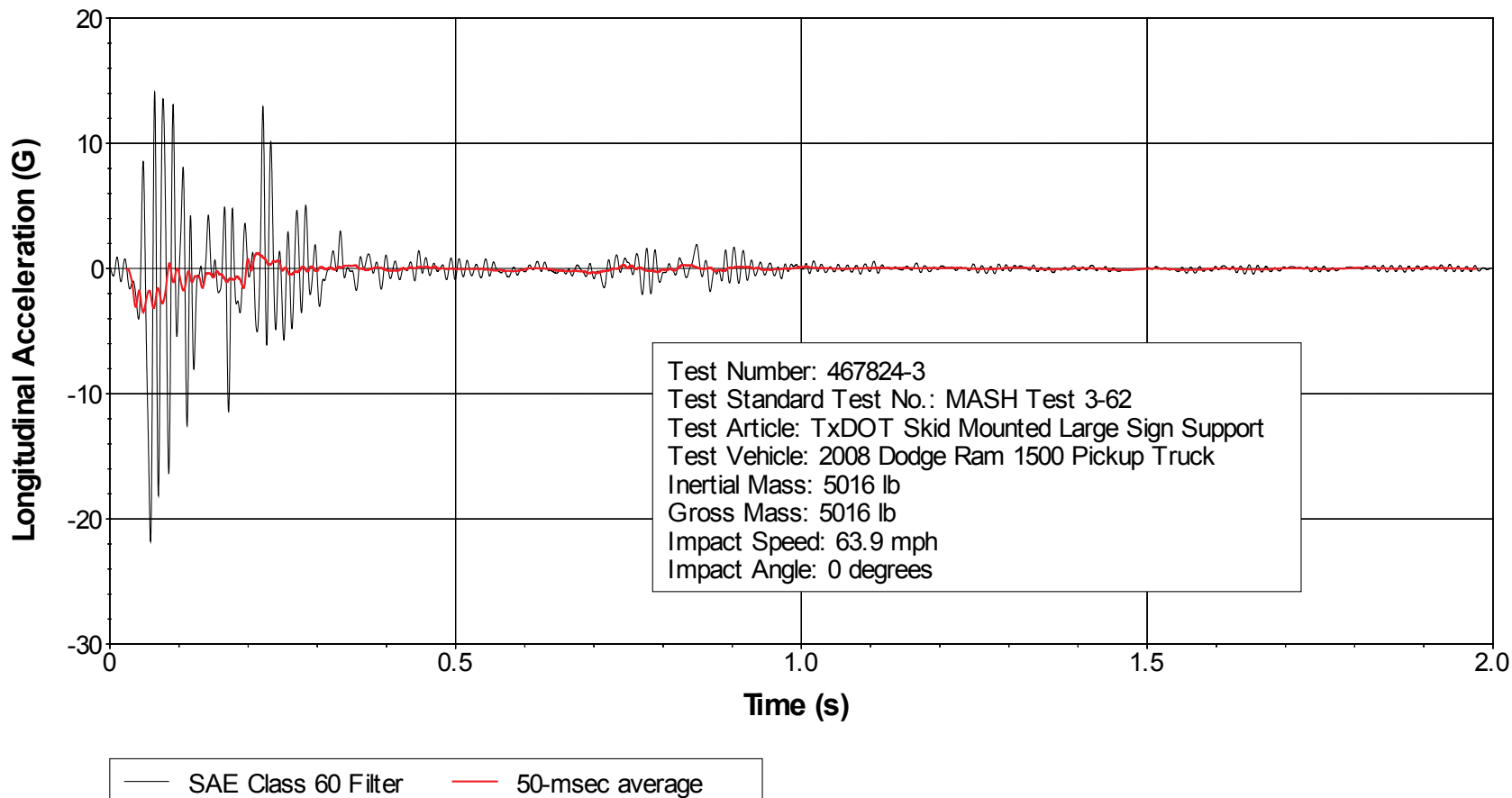

**Figure H5. Vehicle Vertical Accelerometer Trace for Test No. 467824-3 (Accelerometer Located at Center of Gravity).**

# X Acceleration Rear of CG

TR No. 0-6782-2

127



**Figure H6. Vehicle Longitudinal Accelerometer Trace for Test No. 467824-3 (Accelerometer Located Rear of Center of Gravity).**

2014-10-06

### Y Acceleration Rear of CG

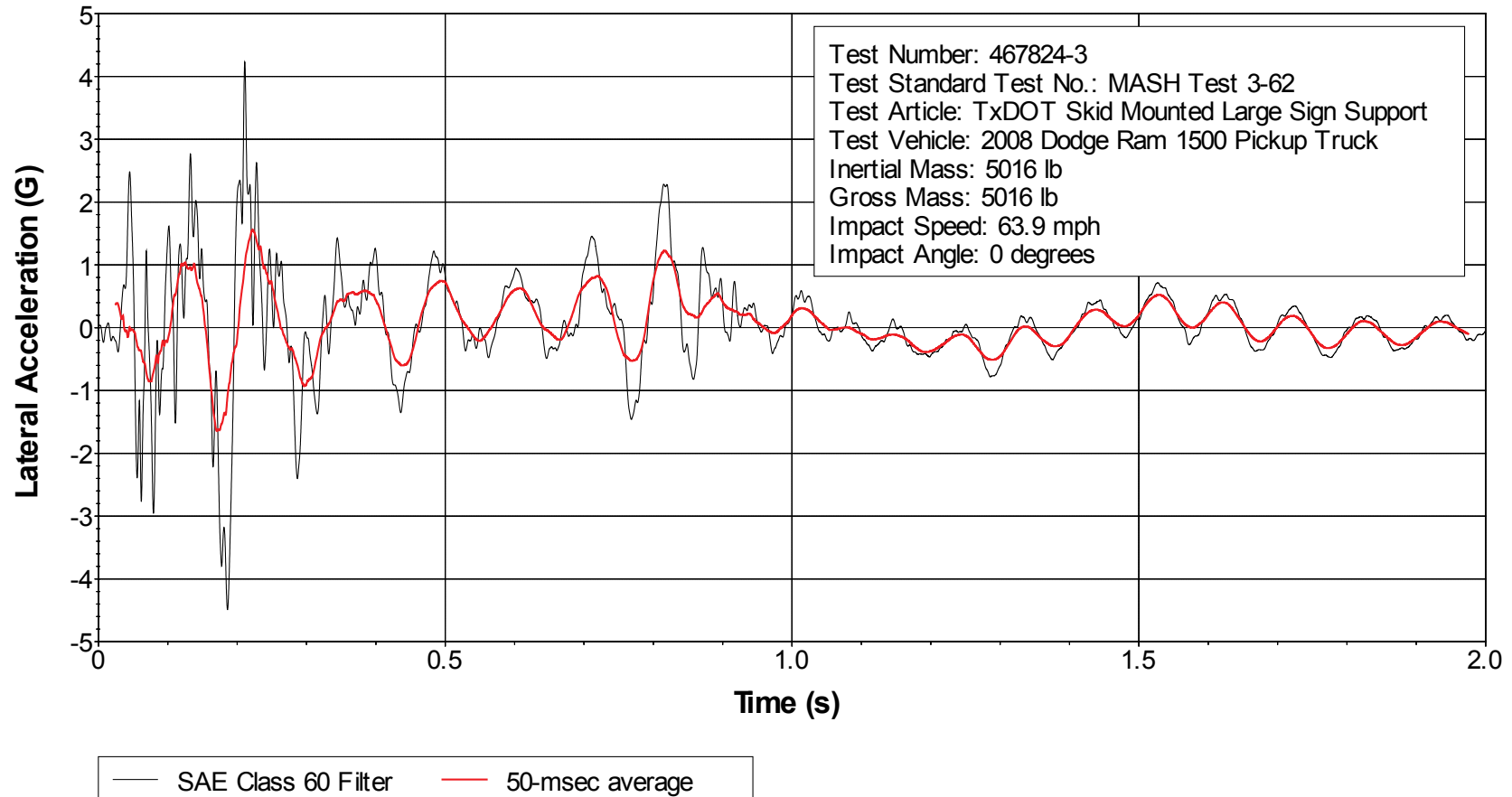
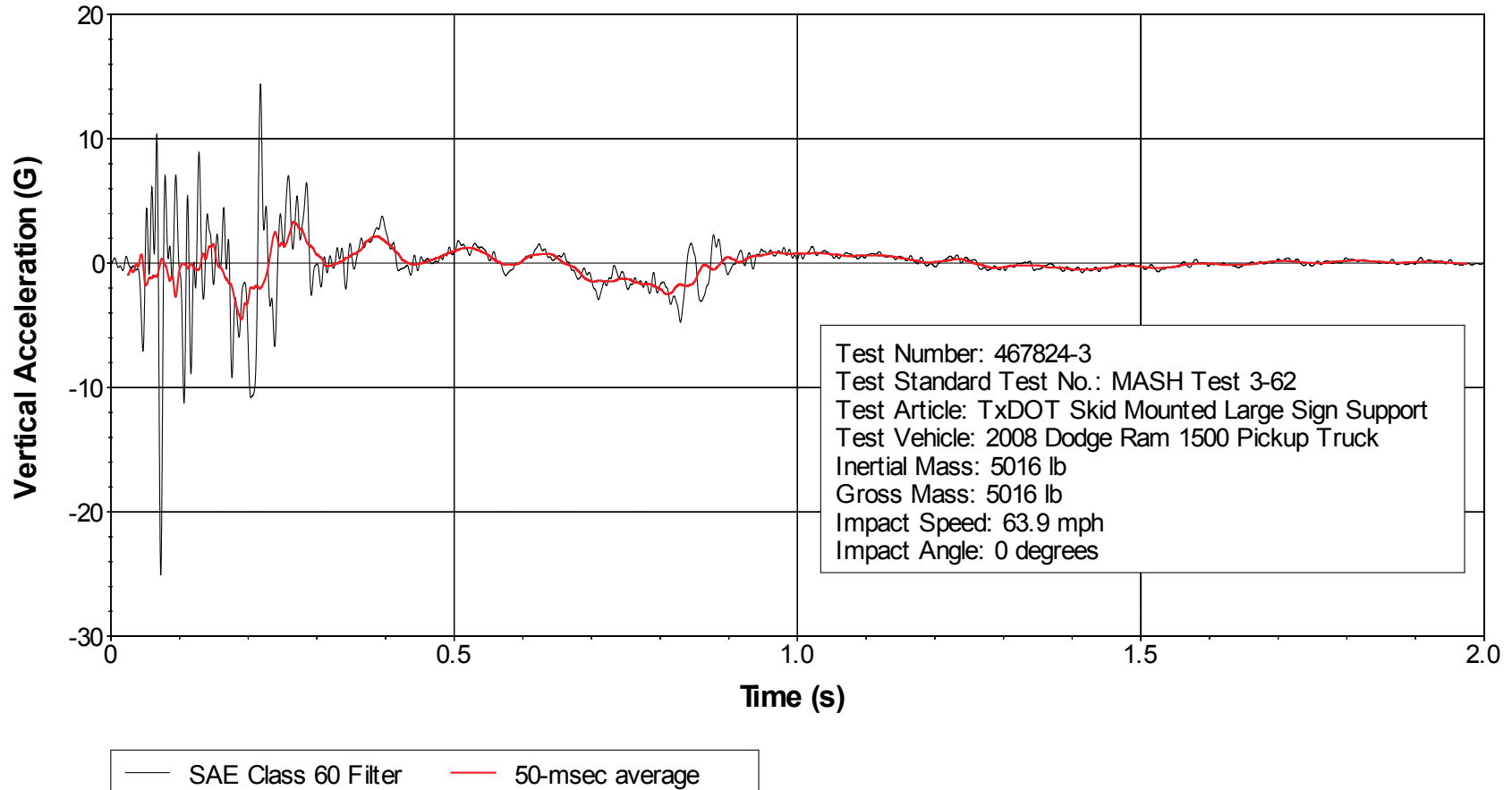

**Figure H7. Vehicle Lateral Accelerometer Trace for Test No. 467824-3 (Accelerometer Located Rear of Center of Gravity).**

# Z Acceleration Rear of CG

TR No. 0-6782-2

129



**Figure H8. Vehicle Vertical Accelerometer Trace for Test No. 467824-3 (Accelerometer Located Rear of Center of Gravity).**

2014-10-06